

# Service Manual

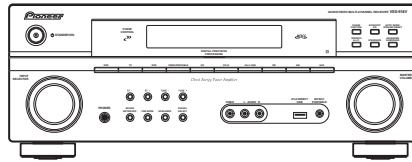

VSX-918V-K

ORDER NO.  
**RRV3736**

**AUDIO/VIDEO MULTI-CHANNEL RECEIVER**

# VSX-918V-K

## VSX-918V-S

## VSX-818V-K

## VSX-818V-S

**THIS MANUAL IS APPLICABLE TO THE FOLLOWING MODEL(S) AND TYPE(S).**

Model	Type	Power Requirement	Remarks
VSX-918V-K	MYSXJ5	AC 220 V to 230 V	
VSX-918V-S	MYSXJ5	AC 220 V to 230 V	
VSX-818V-K	MYSXJ5	AC 220 V to 230 V	
VSX-818V-S	MYSXJ5	AC 220 V to 230 V	



For details, refer to "Important Check Points for good servicing".

# SAFETY INFORMATION



This service manual is intended for qualified service technicians; it is not meant for the casual do-it-yourselfer. Qualified technicians have the necessary test equipment and tools, and have been trained to properly and safely repair complex products such as those covered by this manual.

Improperly performed repairs can adversely affect the safety and reliability of the product and may void the warranty. If you are not qualified to perform the repair of this product properly and safely, you should not risk trying to do so and refer the repair to a qualified service technician.



## WARNING

This product contains lead in solder and certain electrical parts contain chemicals which are known to the state of California to cause cancer, birth defects or other reproductive harm.

Health & Safety Code Section 25249.6 Proposition 65



## NOTICE

(FOR CANADIAN MODEL ONLY)

Fuse symbols  (fast operating fuse) and/or  (slow operating fuse) on PCB indicate that replacement parts must be of identical designation.

## REMARQUE

(POUR MODÈLE CANADIEN SEULEMENT)

Les symboles de fusible  (fusible de type rapide) et/ou  (fusible de type lent) sur CCI indiquent que les pièces de remplacement doivent avoir la même désignation.

## (FOR USA MODEL ONLY)

### 1. SAFETY PRECAUTIONS

The following check should be performed for the continued protection of the customer and service technician.

#### LEAKAGE CURRENT CHECK

Measure leakage current to a known earth ground (water pipe, conduit, etc.) by connecting a leakage current tester such as Simpson Model 229-2 or equivalent between the earth ground and all exposed metal parts of the appliance (input/output terminals, screwheads, metal overlays, control shaft, etc.). Plug the AC line cord of the appliance directly into a 120V AC 60 Hz outlet and turn the AC power switch on. Any current measured must not exceed 0.5 mA.

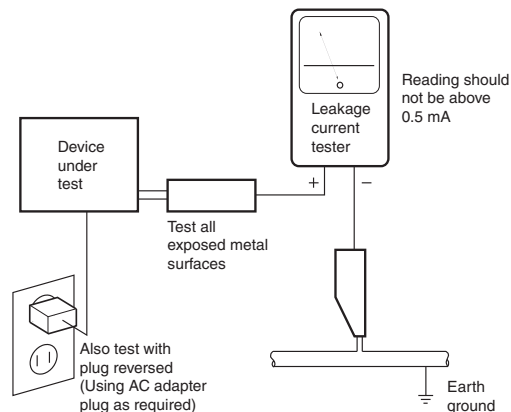

AC Leakage Test

**ANY MEASUREMENTS NOT WITHIN THE LIMITS OUTLINED ABOVE ARE INDICATIVE OF A POTENTIAL SHOCK HAZARD AND MUST BE CORRECTED BEFORE RETURNING THE APPLIANCE TO THE CUSTOMER.**

### 2. PRODUCT SAFETY NOTICE

Many electrical and mechanical parts in the appliance have special safety related characteristics. These are often not evident from visual inspection nor the protection afforded by them necessarily can be obtained by using replacement components rated for voltage, wattage, etc. Replacement parts which have these special safety characteristics are identified in this Service Manual.

Electrical components having such features are identified by marking with a  on the schematics and on the parts list in this Service Manual.

The use of a substitute replacement component which does not have the same safety characteristics as the PIONEER recommended replacement one, shown in the parts list in this Service Manual, may create shock, fire, or other hazards.

Product Safety is continuously under review and new instructions are issued from time to time. For the latest information, always consult the current PIONEER Service Manual. A subscription to, or additional copies of, PIONEER Service Manual may be obtained at a nominal charge from PIONEER.

## [Important Check Points for Good Servicing]

In this manual, procedures that must be performed during repairs are marked with the below symbol. Please be sure to confirm and follow these procedures.

### 1. Product safety



Please conform to product regulations (such as safety and radiation regulations), and maintain a safe servicing environment by following the safety instructions described in this manual.

- ① Use specified parts for repair.

Use genuine parts. Be sure to use important parts for safety.

- ② Do not perform modifications without proper instructions.

Please follow the specified safety methods when modification (addition/change of parts) is required due to interferences such as radio/TV interference and foreign noise.

- ③ Make sure the soldering of repaired locations is properly performed.

When you solder while repairing, please be sure that there are no cold solder and other debris. Soldering should be finished with the proper quantity. (Refer to the example)

- ④ Make sure the screws are tightly fastened.

Please be sure that all screws are fastened, and that there are no loose screws.

- ⑤ Make sure each connectors are correctly inserted.

Please be sure that all connectors are inserted, and that there are no imperfect insertion.

- ⑥ Make sure the wiring cables are set to their original state.

Please replace the wiring and cables to the original state after repairs. In addition, be sure that there are no pinched wires, etc.

- ⑦ Make sure screws and soldering scraps do not remain inside the product.

Please check that neither solder debris nor screws remain inside the product.

- ⑧ There should be no semi-broken wires, scratches, melting, etc. on the coating of the power cord.

Damaged power cords may lead to fire accidents, so please be sure that there are no damages. If you find a damaged power cord, please exchange it with a suitable one.

- ⑨ There should be no spark traces or similar marks on the power plug.

When spark traces or similar marks are found on the power supply plug, please check the connection and advise on secure connections and suitable usage. Please exchange the power cord if necessary.

- ⑩ Safe environment should be secured during servicing.

When you perform repairs, please pay attention to static electricity, furniture, household articles, etc. in order to prevent injuries. Please pay attention to your surroundings and repair safely.

### 2. Adjustments



To keep the original performance of the products, optimum adjustments and confirmation of characteristics within specification. Adjustments should be performed in accordance with the procedures/instructions described in this manual.

### 3. Lubricants, Glues, and Replacement parts



Use grease and adhesives that are equal to the specified substance. Make sure the proper amount is applied.

### 4. Cleaning



For parts that require cleaning, such as optical pickups, tape deck heads, lenses and mirrors used in projection monitors, proper cleaning should be performed to restore their performances.

### 5. Shipping mode and Shipping screws



To protect products from damages or failures during transit, the shipping mode should be set or the shipping screws should be installed before shipment. Please be sure to follow this method especially if it is specified in this manual.

# CONTENTS

- SAFETY INFORMATION ..... 2
- 1. SERVICE PRECAUTIONS ..... 5
  - 1.1 NOTES ON SOLDERING ..... 5
  - 1.2 AMPLIFIER FAILURE DIAGNOSIS FLOW CHART ..... 5
- 2. SPECIFICATIONS ..... 6
  - 2.1 SPECIFICATIONS ..... 6
  - 2.2 PANEL FACILITIES ..... 7
- 3. BASIC ITEMS FOR SERVICE ..... 13
  - 3.1 CHECK POINTS AFTER SERVICING ..... 13
  - 3.2 JIGS LIST ..... 13
  - 3.3 PCB LOCATIONS ..... 14
- 4. BLOCK BIAGRAM ..... 16
  - 4.1 OVERALL WIRING CONNECTION DIAGRAM (VSX-918V) ..... 16
  - 4.2 OVERALL WIRING CONNECTION DIAGRAM (VSX-818V) ..... 18
  - 4.3 BLOCK DIAGRAM (VSX-918V) ..... 20
  - 4.4 BLOCK DIAGRAM (VSX-818V) ..... 22
  - 4.5 DSP BLOCK DIAGRAM ..... 24
  - 4.6 HDMI BLOCK DIAGRAM ..... 25
  - 4.7 USB BLOCK DIAGRAM ..... 26
- 5. DIAGNOSIS ..... 27
  - 5.1 DIAGNOSIS FLOWCHART ..... 27
  - 5.2 DETECTION CIRCUIT ..... 45
  - 5.3 AMPLIFIER SYSTEM PROTECTION OPERATION SPECIFICATION ..... 47
- 6. SERVICE MODE ..... 49
- 7. DISASSEMBLY ..... 50
- 8. EACH SETTING AND ADJUSTMENT ..... 55
  - 8.1 HOW TO UPDATE FIRMWARE ..... 55
- 9. EXPLODED VIEWS AND PARTS LIST ..... 56
  - 9.1 PACKING SECTION ..... 56
  - 9.2 EXTERIOR SECTION ..... 58
  - 9.3 REAR PANEL SECTION ..... 60
  - 9.4 FRONT PANEL SECTION ..... 62
- 10. SCHEMATIC DIAGRAM ..... 64
  - 10.1 MAIN ASSY (1/3) ..... 64
  - 10.2 MAIN ASSY (2/3) ..... 66
  - 10.3 MAIN ASSY (3/3) ..... 68
  - 10.4 DSP & USB ASSY (1/4) ..... 70
  - 10.5 DSP & USB ASSY (2/4) ..... 72
  - 10.6 DSP & USB ASSY (3/4) ..... 74
  - 10.7 DSP & USB ASSY (4/4) ..... 76
  - 10.8 POWER PACK (1/2) and TRANS2 ASSYS ..... 78
  - 10.9 POWER PACK ASSY (2/2) ..... 80
  - 10.10 COMPONENT VIDEO, 5.1CH INPUT and TRANS3 ASSYS ..... 82
  - 10.11 FRONT DISPLAY, ROTARY ENCODER, POWER KEY and JOG ASSYS ..... 84
  - 10.12 DIGITAL INPUT, REGULATOR and HEAD PHONE ASSYS ..... 86
  - 10.13 VIDEO, PRIMARY and FRONT VIDEO ASSYS ..... 88
  - 10.14 FRONT IN ASSY ..... 90
  - 10.15 HDMI & DSP & USB ASSY (1/5) ..... 92
  - 10.16 HDMI & DSP & USB ASSY (2/5) ..... 94
  - 10.17 HDMI & DSP & USB ASSY (3/5) ..... 96
  - 10.18 HDMI & DSP & USB ASSY (4/5) ..... 98
  - 10.19 HDMI & DSP & USB ASSY (5/5) ..... 100
- 11. PCB CONNECTION DIAGRAM ..... 102
  - 11.1 DSP & USB and HDMI ASSYS ..... 102
  - 11.2 MAIN ASSY ..... 106
  - 11.3 POWER PACK ASSY ..... 110
  - 11.4 TRANS2 and TRANS3 ASSYS ..... 114
  - 11.5 COMPONENT VIDEO ASSY ..... 116
  - 11.6 5.1CH INPUT and HEAD PHONE ASSYS ..... 117
  - 11.7 FRONT DISPLAY, ROTARY ENCODER, POWER KEY and JOG ASSYS ..... 118
  - 11.8 DIGITAL INPUT and FRONT VIDEO ASSYS ..... 122
  - 11.9 REGULATOR ASSY ..... 123
  - 11.10 VIDEO ASSY ..... 124
  - 11.11 FRONT IN ASSY ..... 125
  - 11.12 PRIMARY ASSY ..... 126
  - 11.13 HDMI & DSP & USB ASSY ..... 128
- 12. ELECTRICAL PARTS LIST ..... 132

# 1. SERVICE PRECAUTIONS

## 1.1 NOTES ON SOLDERING

- For environmental protection, lead-free solder is used on the printed circuit boards mounted in this unit.  
Be sure to use lead-free solder and a soldering iron that can meet specifications for use with lead-free solders for repairs accompanied by reworking of soldering.
- Compared with conventional eutectic solders, lead-free solders have higher melting points, by approximately 40 °C. Therefore, for lead-free soldering, the tip temperature of a soldering iron must be set to around 373 °C in general, although the temperature depends on the heat capacity of the PC board on which reworking is required and the weight of the tip of the soldering iron.

Do NOT use a soldering iron whose tip temperature cannot be controlled.

Compared with eutectic solders, lead-free solders have higher bond strengths but slower wetting times and higher melting temperatures (hard to melt/easy to harden).

The following lead-free solders are available as service parts:

- Parts numbers of lead-free solder:  
GYP1006 1.0 in dia.  
GYP1007 0.6 in dia.  
GYP1008 0.3 in dia.

## 1.2 AMPLIFIER FAILURE DIAGNOSIS FLOW CHART

### ■ Amplifier failure diagnosis flow chart

When DC detection is activated ("AMP\_ERR" flashes on the display), failure (damage) of the power amplifier section is considered.

#### Caution:

**When releasing the lock state of power key before repair, please be careful because there is the possibility that more damages will occur when turning on the power once again!**

- According to a symptom, perform the following confirmation beforehand.
  - 1) Are there any Fuses and IC protectors open?  
↓
  - 2) After turn on the power, confirm that the supply voltage of the point that can be measured is appropriate. (Particularly the supply voltage of the power Tr and drive step)  
↓
  - 3) Whether the voltage of pin2 and pin5 of IC601 or IC603 is equal to (VL-0.7V). If not (eg, equal to VH), then change the corresponding power pack IC601 or IC603.  
↓
  - 4) Furthermore, check the output DC voltage of each channel of power pack IC601 and IC603 to limit the failure channel and identify the defect power pack.  
↓
- After identify the failure channel, check that each part is not damaged (resistor, diode... etc. value / open / short)

# 2. SPECIFICATIONS

## 2.1 SPECIFICATIONS

- A Amplifier section**
- **Continuous power output (stereo)**  
Front. . . . . 100 W + 100 W  
(DIN 1 kHz, THD 1.0 %, 8 Ω)
  - **Rated power output**  
(surround / 20 Hz to 20 kHz, THD 0.06 %, 8 Ω)  
Front. . . . . .95 W per channel  
Center . . . . . .95 W  
Surround. . . . . .95 W per channel
  - **Rated power output**  
(surround / 1 kHz, THD 1.0 %, 8 Ω)  
Front. . . . . .130 W per channel  
Center . . . . . .130 W  
Surround. . . . . .130 W per channel
- B**

### Audio section

- **Input (Sensitivity/Impedance)**  
AUX, CD, CD-R/TAPE/MD, DVD/BD,  
TV/SAT, DVR/VCR. . . . . .335 mV/47 kΩ
- **Frequency response**  
AUX, CD, CD-R/TAPE/MD, DVD/BD,  
TV/SAT, DVR/VCR. . . . . 5 Hz to 100 000 Hz  $\pm 3$  dB
- **Output (Level/Impedance)**  
CD-R/TAPE/MD, DVR/VCR . . . . . 335 mV/2.2 kΩ
- **Tone control**  
Bass. . . . .  $\pm 6$  dB (100 Hz)  
Treble. . . . .  $\pm 6$  dB (10 kHz)  
Loudness. . . . . +10 dB/+5 dB (100 Hz/10 kHz)  
(at volume level -50 dB)
- **Signal-to-Noise Ratio DIN (Continuous rated power output / 50 mW)**  
AUX, CD, CD-R/TAPE/MD, DVD/BD,  
TV/SAT, DVR/VCR. . . . . .88 dB/64 dB

### Video Section

- **Input (Sensitivity/Impedance)**  
DVR/VCR, DVD/BD, TV/SAT. . . . . 1 Vp-p/75 Ω
- **Output (Level/Impedance)**  
DVR/VCR, MONITOR OUT. . . . . 1 Vp-p/75 Ω
- **Frequency response**  
DVR/VCR, DVD/BD,  
TV/SAT  $\Rightarrow$  MONITOR . . . . . 5 Hz to 7 MHz  $\pm 3$  dB  
Signal-to-Noise Ratio . . . . . .55 dB  
Crosstalk . . . . . .50 dB

Manufactured under license from Dolby Laboratories. "Dolby", "Pro Logic" and the double-D symbol are trademarks of Dolby Laboratories.

"DTS" is a registered trademark of DTS, Inc. and "DTS 96/24" is a trademark of DTS, Inc.

### Component video section

- **Input (Sensitivity/Impedance)**  
DVD/BD, TV/SAT, DVR/VCR. . . . . 1 Vp-p/75 Ω
- **Output (Level/Impedance)**  
MONITOR OUT . . . . . 1 Vp-p/75 Ω
- **Frequency response**  
DVD/BD, TV/SAT,  
DVR/VCR  $\Rightarrow$  MONITOR . . . 5 Hz to 40 MHz  $\pm 3$  dB  
Signal-to-Noise Ratio . . . . . .60 dB

### HDMI Section

- Input. . . . . 19 pin x2
- Output . . . . . 19 pin (5 V, 55 mA)

### FM Tuner Section

- Frequency Range . . . . . 87.5 MHz to 108 MHz
- Usable Sensitivity . . . . . Mono:13.2 dBf, IHF  
(1.3  $\mu$ V/75 Ω)  
50 dB Quieting Sensitivity . . . . . Mono: 20.2 dBf  
Stereo: 38.6 dBf
- Signal-to-Noise Ratio . . . Mono: 73 dB (at 85 dBf)  
Stereo: 70 dB (at 85 dBf)
- Distortion. . . . . Stereo: 0.5 % (1 kHz)
- Alternate Channel Selectivity. . . . . .60 dB  
(400 kHz)
- Stereo Separation. . . . . 40 dB (1 kHz)
- Frequency Response . . . . . 30 Hz to 15 kHz  
( $\pm 1$  dB)
- Antenna Input (DIN). . . . . 75 Ω unbalanced

### AM Tuner Section

- Frequency Range . . . . . 531 kHz to 1602 kHz
- Sensitivity (IHF, Loop antenna) . . . . . 350  $\mu$ V/m
- Signal-to-Noise Ratio . . . . . .50 dB
- Antenna. . . . . Loop antenna

### Miscellaneous

- Power requirements  
. . . . . AC 220 V to 230 V, 50 Hz/60 Hz
- Power consumption . . . . . 290 W  
In standby. . . . . 0.5 W
- Dimensions  
. . . . . 420 mm (W) x 158 mm (H) x 352.5 mm (D)
- Weight (without package). . . . . 8.1 kg

### Furnished Parts

- Microphone (for Auto MCACC setup) . . . . . 1
- Remote control . . . . . 1
- Dry cell batteries (AA size IEC R6) . . . . . 2
- AM loop antenna. . . . . 1
- FM wire antenna . . . . . 1
- Warranty card . . . . . 1
- Operating instructions

### Note

- Specifications and the design are subject to possible modifications without notice, due to improvements.

### Accessories

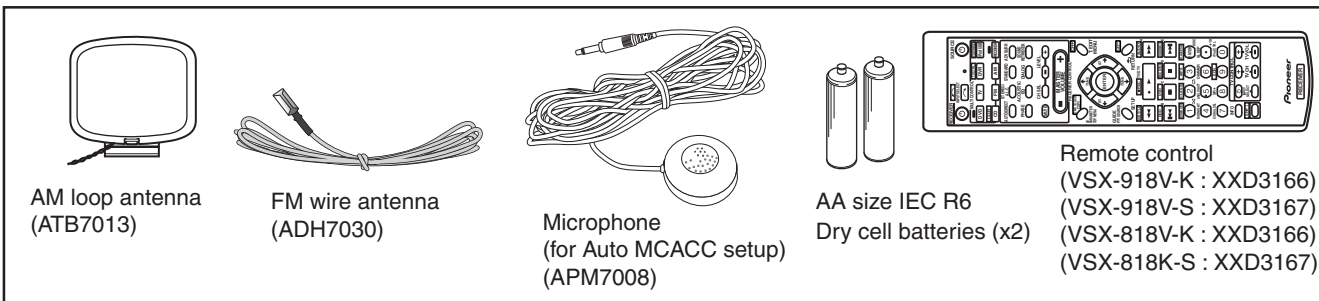

AM loop antenna (ATB7013)

FM wire antenna (ADH7030)

Microphone (for Auto MCACC setup) (APM7008)

AA size IEC R6 Dry cell batteries (x2)

Remote control  
(VSX-918V-K : XXD3166)  
(VSX-918V-S : XXD3167)  
(VSX-818V-K : XXD3166)  
(VSX-818K-S : XXD3167)

## 2.2 PANEL FACILITIES

### Front panel

Illustration shows the VSX-918V model

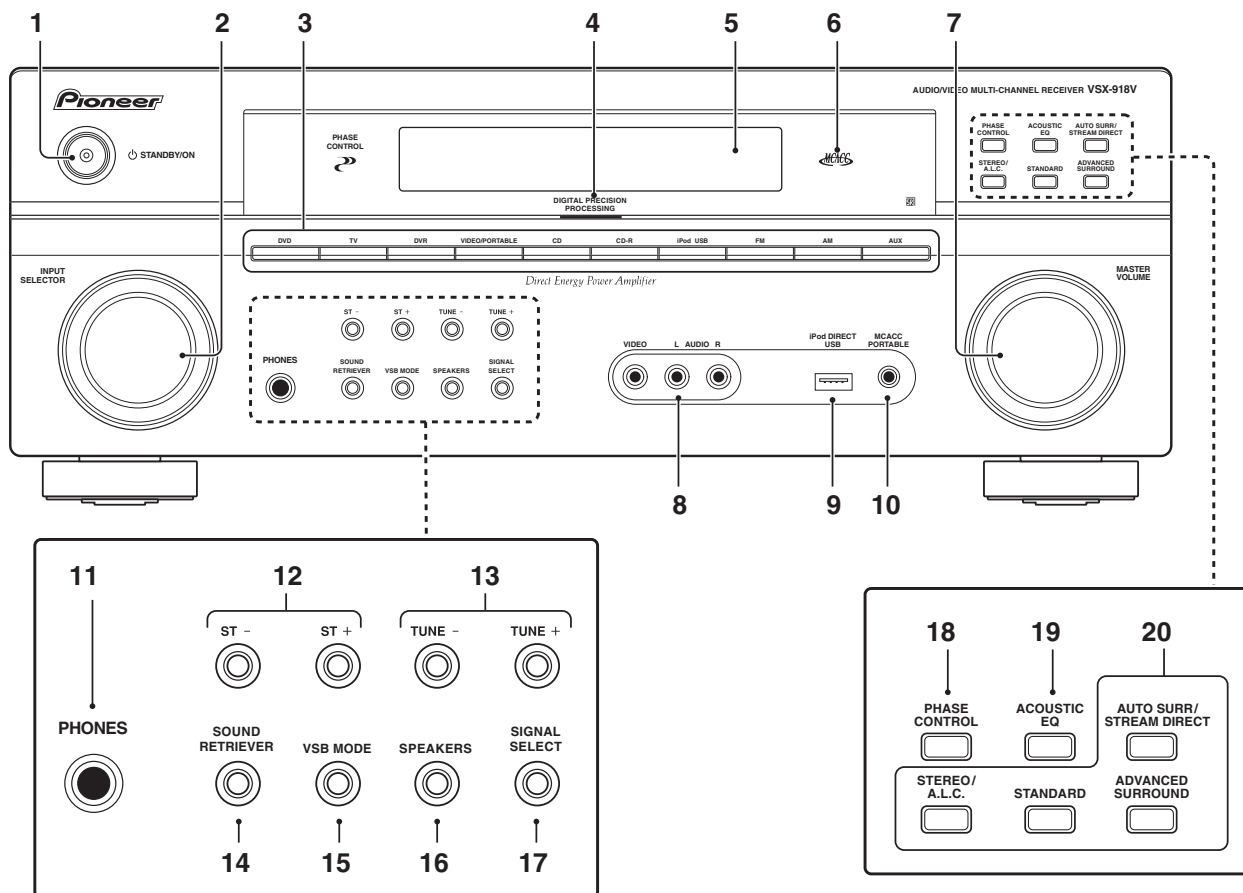

1 **STANDBY/ON**

2 **INPUT SELECTOR dial**

Selects an input source.

3 **Input select buttons**

Selects an input source.

4 **Digital Precision Processing indicator**

(VSX-918V model only)

Lights to indicate digital processing.

5 **Character display**

6 **MCACC indicator**

Lights when Acoustic Calibration EQ is on (Acoustic Calibration EQ is automatically set to **ALL CH ADJUST** after the Auto MCACC Setup or EQ Auto Setup).

7 **MASTER VOLUME dial**

8 **AUDIO/VIDEO input**

9 **iPod DIRECT USB terminal**

Use to connect your Apple iPod as an audio source, or connect a USB audio device for playback.

10 **MCACC PORTABLE jack**

Use to connect a microphone when performing Auto MCACC setup, or connect an auxiliary component using a stereo mini-jack cable.

11 **PHONES jack**

Use to connect headphones (when connected, there is no sound output from the speakers (except speaker system B connections)).

12 **ST +/-**

Use to select preset radio stations.

13 **TUNE +/-**

Used to find radio frequencies.

14 **SOUND RETRIEVER**

Press to restore CD quality sound to compressed audio sources.

15 **VSB MODE**

Press to switch on/off Virtual Surround Back (VSB) mode.

16 **SPEAKERS**

Use to change the speaker system and the impedance setting.

17 **SIGNAL SELECT**

Selects an input signal.

**18 PHASE CONTROL**

Press to switch on/off Phase Control.

**19 ACOUSTIC EQ**

Press to select an Acoustic Calibration EQ setting.

**20 Listening mode buttons**

**AUTO SURR/STREAM DIRECT**

Switches between Auto surround mode (Auto playback on) and Stream Direct playback. Stream Direct playback bypasses the tone controls for the most accurate reproduction of a source.

**STEREO/A.L.C.**

Switches between stereo playback, Auto level control stereo mode and Front Stage Surround Advance modes.

**STANDARD**

Press for Standard decoding and to switch between the various **PRO LOGIC II** options.

**ADVANCED SURROUND**

Switches between the various surround modes.

VSX-918V

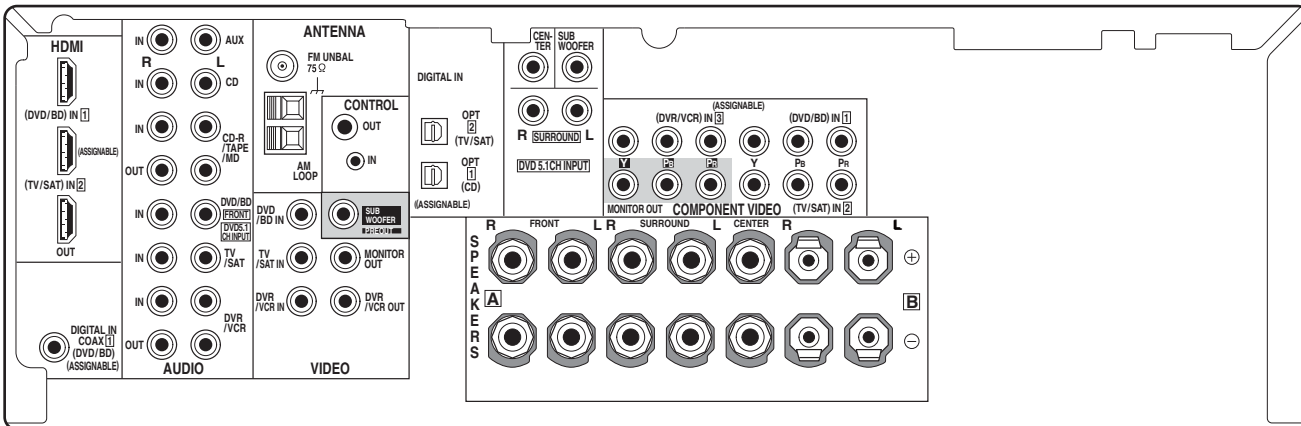

## Display

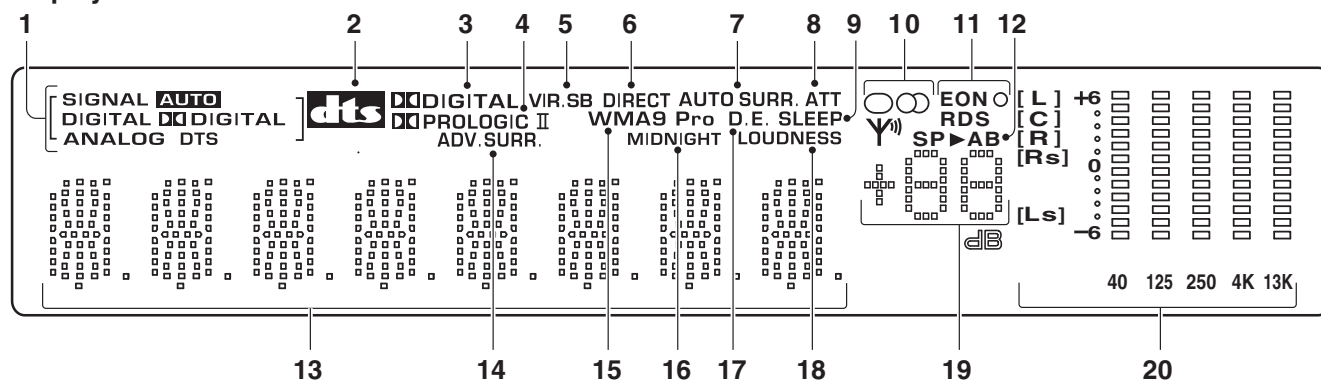

### 1 SIGNAL indicators

Lights to indicate the type of input signal:

#### AUTO

Lights when **AUTO** signal select is on.

#### DIGITAL

Lights when a digital audio signal is detected.

#### □□ DIGITAL

Lights when a Dolby Digital encoded signal is detected.

#### ANALOG

Lights when an analog signal is detected.

#### DTS

Lights when a source with DTS encoded audio signals is detected.

### 2

Lights to indicate decoding of a DTS multichannel signal.

### 3

Lights to indicate decoding of a Dolby Digital multichannel signal.

### 4

Lights to indicate Pro Logic II decoding.

### 5 VIR. SB

Lights during Virtual surround back processing.

### 6 DIRECT

Lights when source Stream Direct playback is in use. Direct playback bypasses the tone controls for the most accurate reproduction of a source.

### 7 AUTO SURR.

Lights when the Auto Surround feature is switched on.

### 8 ATT

Lights when **ANALOG ATT** is used to attenuate (reduce) the level of the analog input signal.

### 9 SLEEP

Lights when the sleep mode is active.

### 10 Tuner indicators

#### ○ / MONO

Lights when the mono mode is set using the **MPX** button.

#### ⊙ / STEREO

Lights when a stereo FM broadcast is being received in auto stereo mode.

### Y<sup>TM</sup> / TUNED

Lights when a broadcast is being received.

### 11 EON/RDS indicators

#### EON

Lights when the EON mode is set, and flashes during an EON broadcast. The **O** indicator lights when the current station carries the EON service.

#### RDS

Lights when an RDS broadcast is received.

### 12 Speaker indicators

Lights to indicate the current speaker system, **A** and/or **B**.

### 13 Character display

#### 14 ADV. SURR. (Advanced Surround)

Lights when one of the Advanced Surround modes has been selected.

#### 15 WMA9 Pro

Lights to indicate decoding of a WMA9 Pro signal.

#### 16 MIDNIGHT

Lights during Midnight listening.

#### 17 D.E.

Lights when Dialog Enhancement is switched on.

#### 18 LOUDNESS

Lights during Loudness listening.

#### 19 Master volume level

Shows the overall volume level.

#### 20 MCACC channel EQ / Sound Retriever / HDMI indicators

These indicators show the EQ balance for each channel in Checking your Acoustic Calibration EQ settings. Also, **L** and **R** light when the Sound Retriever is active.

In addition, the HDMI connection state is displayed as shown below.

Blinks when connecting an HDMI-equipped component: lights when the component is connected.



## Remote control Illustration shows the VSX-918V model

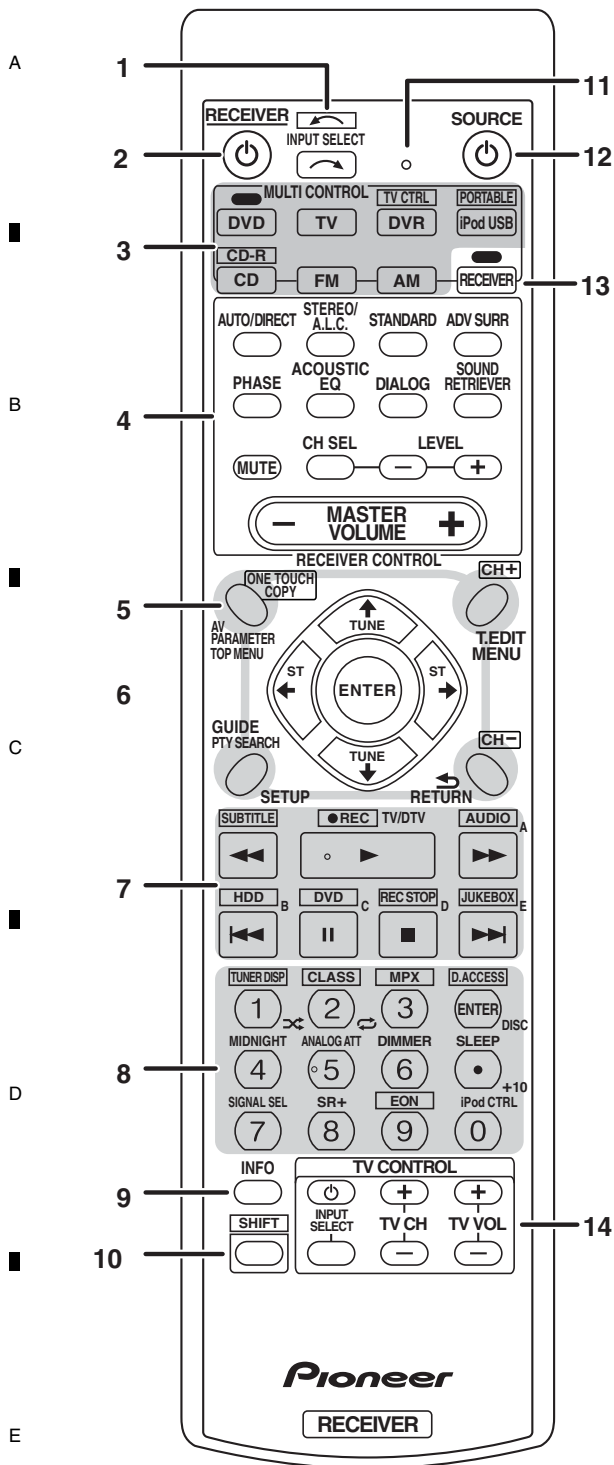

### 1 INPUT SELECT

Use to select the input source (use **SHIFT** for **INPUT SELECT** ).

### 2 RECEIVER

Switches the receiver between standby and on.

### 3 MULTI CONTROL buttons

Press to select control of other components.

**TV CTRL**, **PORTABLE** and **CD-R** buttons can be used with **SHIFT** button.

## 4 RECEIVER CONTROL buttons

### AUTO/DIRECT

Switches between Auto surround mode (Auto playback on) and Stream Direct playback. Direct playback bypasses the tone controls for the most accurate reproduction of a source.

### STEREO/A.L.C.

Switches between stereo playback, Auto level control stereo mode and Front Stage Surround Advance modes.

### STANDARD

Press for Standard decoding and to switch between  Pro Logic II options.

### ADV SURR

Switches between the various surround modes.

### PHASE

Press to switch on/off Phase Control.

### ACOUSTIC EQ

Press to select an Acoustic Calibration EQ setting.

### DIALOG

Use to make dialog stand out when watching TV or a movie.

### SOUND RETRIEVER

Press to restore CD quality sound to compressed audio sources.

### MUTE

Mutes/unmutes the sound.

### CH SEL

Press repeatedly to select a channel, then use **LEVEL +/-** to adjust the level.

### LEVEL +/-

Use to adjust the channel levels.

### MASTER VOLUME +/-

Use to set the listening volume.

## 5 System Setup and Component control buttons

The following button controls can be accessed after you have selected the corresponding **MULTI CONTROL** button (**DVD**, **DVR**, **RECEIVER**, etc.).

### AV PARAMETER

Use to access the AV options.

### TOP MENU

Displays the disc 'top' menu of a DVD.

### ONE TOUCH COPY\*

Copies the currently playing title from DVD to HDD or vice-versa.

### GUIDE

Displays/changes the subtitles on multilingual DVDs.

### PTY SEARCH

Use to search for RDS program types.

### SETUP

Press to access the System Setup menu. Also functions as the **SETUP** button for DVD/DVR units.

**T.EDIT**

Memorizes/names stations for recall.

**MENU**

Displays the disc menu of DVD-Video discs.

**RETURN**

Confirm and exit the current menu screen.

**CH +/-\***

Use to select channels for DVD/DVR units.

**6 ↑↓←→ (TUNE↑/↓, ST←/→), ENTER**

Use the arrow buttons when setting up your surround sound system. Also used to control DVD menus/options.

Use the **TUNE↑/↓** buttons can be used to find radio frequencies and the **ST←/→** buttons can be used to select preset radio stations.

**7 Component control buttons**

The main buttons (▶, ■, etc.) are used to control a component after you have selected it using the **MULTI CONTROL** buttons.

The controls above these buttons can be accessed after you have selected the corresponding **MULTI CONTROL** button (for example **DVD, DVR** or **TV** (when connected to a DTV)).

**SUBTITLE\***

Displays/changes the subtitles included in multilingual DVD-Video discs.

**● REC\***

Start recording.

**AUDIO\***

Changes the audio language or channel on DVD discs.

**HDD\*, DVD\***

These buttons switch between the hard disk and DVD controls for HDD/DVD recorders.

**REC STOP\***

Stops recording.

**JUKEBOX\***

Switches to the Jukebox feature.

**TV/DTV**

Switches between the analog TV and DTV input modes for Pioneer flat screen TVs.

**8 Number buttons and other component controls**

Use the number buttons to directly select a radio frequency or the tracks on a CD, DVD, etc. There are other buttons that can be accessed after the **RECEIVER** button is pressed. (For example **MIDNIGHT**, etc.)

**TUNER DISP\***

Switches between named station presets and radio frequencies.

**CLASS\***

Switches between the three banks (classes) of radio station presets.

**MPX\***

Switches between stereo and mono reception of FM broadcasts. If the signal is weak then switching to mono will improve the sound quality.

**D.ACCESS\***

After pressing, you can access a radio station directly using the number buttons.

**MIDNIGHT**

Switches to Midnight or Loudness listening.

**ANALOG ATT**

Attenuates (lowers) the level of an analog input signal to prevent distortion.

**DIMMER**

Dims or brightens the display.

**SLEEP**

Press to change the amount of time before the receiver switches into standby (**30 min – 60 min – 90 min – Off**). You can check the remaining sleep time at any time by pressing **SLEEP** once.

**SIGNAL SEL**

Use to select an input signal.

**SR + (VSX-918V model only)**

Switches the SR+ mode on/off.

**EON\***

Use to search for programs that are broadcasting traffic or news information.

**iPod CTRL**

Switches between the iPod controls and the receiver controls.

**DISC (ENTER)**

Use to enter commands for TV or DTV, and also use to select a disc in a multi-CD player.

**9 INFO**

Use to bring up information screens on a digital TV.

**10 SHIFT**

Press to access the 'boxed' commands (above the buttons) on the remote. These buttons are marked with an asterisk (\*) in this section.

**11 Remote control LED**

Lights when a command is sent from the remote control.

**12 SOURCE**

Press to turn on/off other components connected to the receiver.

**13 RECEIVER**

Switches the remote to control the receiver (used to select the green commands above the number buttons (**SETUP**, etc)). Also use this button to set up surround sound.

**14 TV CONTROL buttons**

These buttons are dedicated to control the TV assigned to the **TV CTRL** button. Thus if you only have one TV to hook up to this system assign it to the **TV CTRL MULTI CONTROL** button. If you have two TVs, assign the main TV to the **TV CTRL** button.

⏻ Use to turn on/off the power of the TV.

**INPUT SELECT**

Use to select the TV input signal.

**TV CH +/-**

Use to select channels.

**TV VOL +/-**

Use to adjust the volume on your TV.

## Using this receiver with a Pioneer flat screen TV

(VSX-918V model only)

If you have a Pioneer flat screen TV <sup>1</sup>, you can use an SR+ cable to connect it to this unit and take advantage of various convenient features, such as automatic video input switching of the flat screen TV when the input is changed.

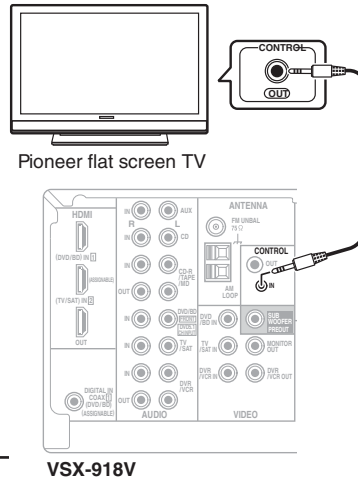

### SERVICE PARTS

- SR+ mini-plug cable (ADE7095)

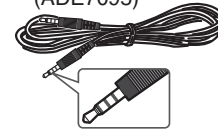

**Note**

<sup>1</sup> This receiver is compatible with all Pioneer flat screen TVs from 2003 onward.

- Use a 3-ringed miniplug SR+ cable <sup>1</sup> to connect the CONTROL IN jack of this receiver with the CONTROL OUT of your flat screen TV.

Before you can use the extra SR+ features, you need to make a few settings in the receiver.

### Using the SR+ mode with a Pioneer flat screen TV

When connected using an SR+ cable, a number of features become available to make using this receiver with your Pioneer flat screen TV even easier. These features include:

- On-screen volume display.
- On-screen display of listening mode.
- Automatic video input switching on the flat screen TV.
- Automatic volume muting on the flat screen TV.<sup>2</sup>

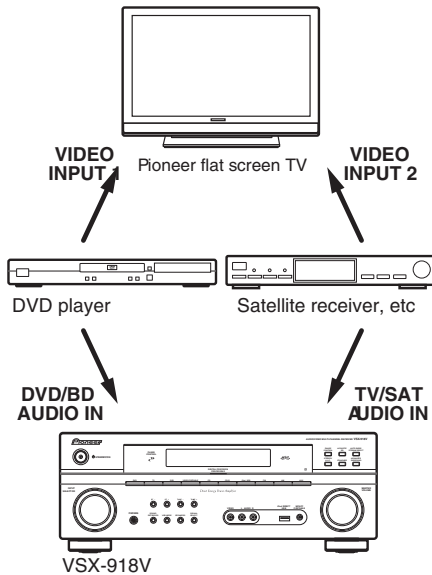

**1** Make sure that the flat screen TV and this receiver are switched on and that they are connected with the SR+ cable.

**2** To switch SR+ mode on/off, press **RECEIVER**, then the **SR+** button. The front panel display shows SR+ ONorOFF.

To make the most of the SR+ features, you should connect your source components (DVD player, etc.) in a slightly different way to that described in this chapter. For each component, connect the video output directly to the flat screen TV, and just connect the audio (analog and/or digital) to this receiver.

**Note**

- <sup>1</sup> The 3-ringed SR+ cable from Pioneer is commercially available under the part number ADE7095. Contact the Pioneer Customer Support division for more information on obtaining an SR+ cable (you can also use a commercially available 3-ringed mini phone plug for the connection).
- If you connect to a Pioneer flat screen TV using an SR+ cable, you will need to point the remote control at the flat screen TV remote sensor to control the receiver. In this case, you won't be able to control the receiver using the remote control if you switch the flat screen TV off.
- <sup>2</sup> The automatic volume muting feature is enabled separately.

## 3. BASIC ITEMS FOR SERVICE

### 3.1 CHECK POINTS AFTER SERVICING

To keep the product quality after servicing, confirm recommended check points shown below.

No.	Procedure	Check points
1	Confirm whether the customer complain has been solved. If the customer complain occurs with the particular source, such as Dolby Digital, DTS, AAC, DVD-A and HDMI, input it for the operation check.	The customer complain must not be reappeared. Video, Audio and operations must be normal.
2	Check the analog audio playback. (Make the analog connections with a DVD player.)	Each channel audio and operations must be normal.
3	Check the digital audio playback. (Make the digital connections with a DVD player.)	Each channel audio and operations must be normal.
4	Check surround playback. (Select Surround mode and check the multichannel operations via the DSP circuit.)	Each channel audio and operations must be normal.
5	Check the video outputs. (Connect with a DVD player.)	Video and operations must be normal.
6	Check the sound from headphone output.	Sound must be normal, without noise.
7	Check the appearance of the product.	No scratches or dirt on its appearance after receiving it for service.

See the table below for the items to be checked regarding video and audio:

Items to be checked regarding video	Item to be checked regarding audio
Block noise	Distortion
Horizontal noise	Noise
Dot noise	Volume too low
Disturbed image (video jumpiness)	Volume too high
Too dark	Volume fluctuating
Too bright	Sound interrupted
Mottled color	

### ■ CLEANING



Before shipping out the product, be sure to clean the following positions by using the prescribed cleaning tools:

Position to be cleaned	Cleaning tools
Fans	Cleaning paper : GED-008

### 3.2 JIGS LIST

#### ■ Jigs list

Name	Jig No.	Remarks
13P board to board extension jig cable	GGD1483	Diagnosis
21P board to board extension jig cable	GGD1485	Diagnosis

### 3.3 PCB LOCATIONS

#### VSX-918V

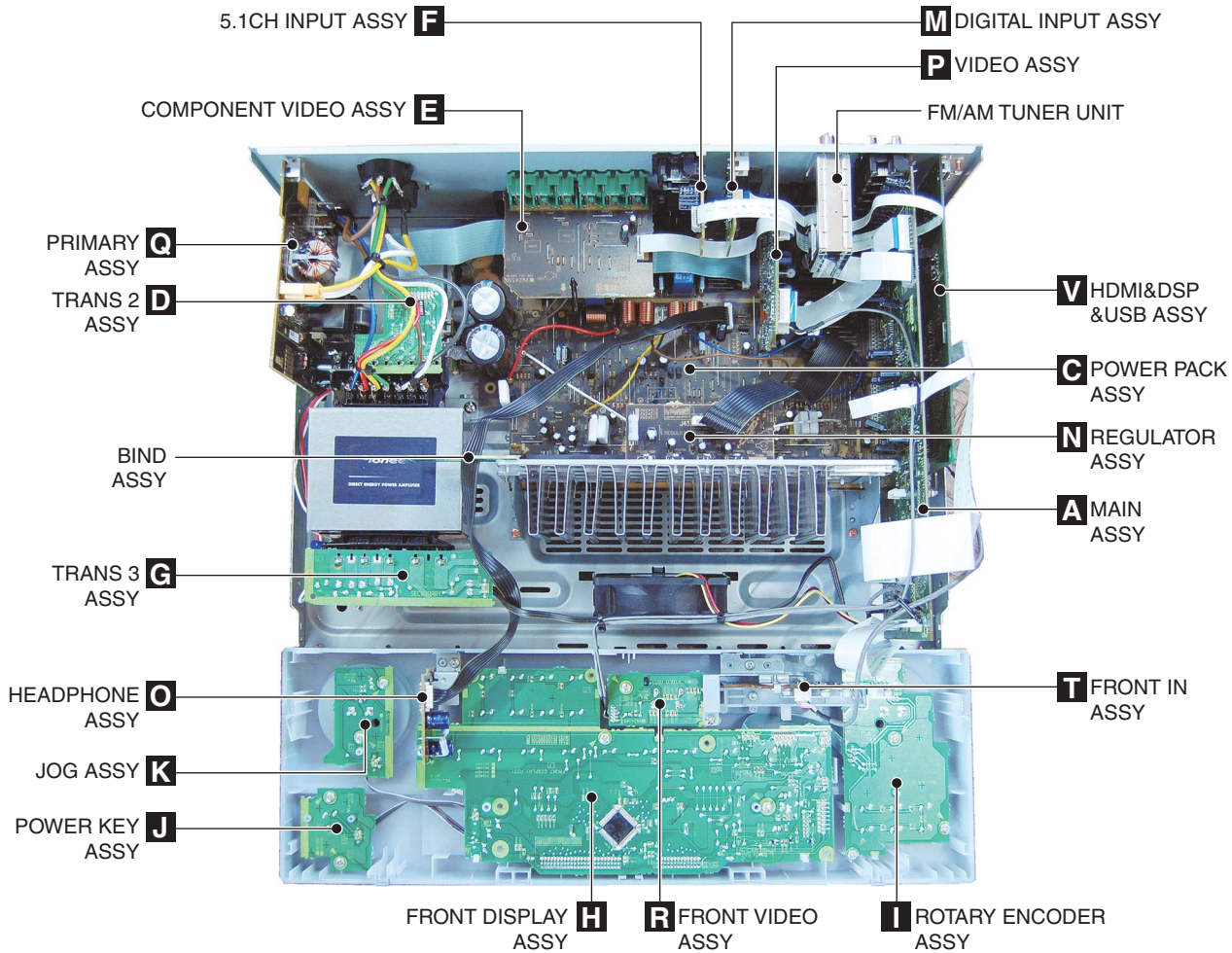

NOTES: ● Parts marked by "NSP" are generally unavailable because they are not in our Master Spare Parts List.  
 ● The ⚠ mark found on some component parts indicates the importance of the safety factor of the part.  
 Therefore, when replacing, be sure to use parts of identical designation.

Mark No.	Description	Part No.	Mark No.	Description	Part No.
<b>LIST OF ASSEMBLIES</b>					
	1..HDMI&DSP&USB ASSY	AWX8977	NSP	1..AMP ASSY	XWK3349
NSP	1..COMPLEX ASSY	XWK3341		2..POWER PACK ASSY	XWZ4326
	2..FRONT DISPLAY ASSY	XWZ4285		2..TRANS 2 ASSY	XWZ4335
	2..ROTARY ENCODER ASSY	XWZ4286		2..TRANS 3 ASSY	XWZ4337
	2..POWER KEY ASSY	XWZ4288		2..COMPONENT VIDEO ASSY	XWZ4339
	2..JOG ASSY	XWZ4289		2..5.1CH INPUT ASSY	XWZ4341
	2..VIDEO ASSY	XWZ4294		2..BIND ASSY	XWZ4344
	2..DIGITAL INPUT ASSY	XWZ4299	1..MAIN ASSY		XWK3363
	2..FRONT VIDEO ASSY	XWZ4300	1..FRONT IN ASSY		XWK3366
	2..PRIMARY ASSY	XWZ4302	1..FM/AM TUNER UNIT		AXX7170
	2..REGULATOR ASSY	XWZ4317			
	2..HEADPHONE ASSY	XWZ4321			

## VSX-818V

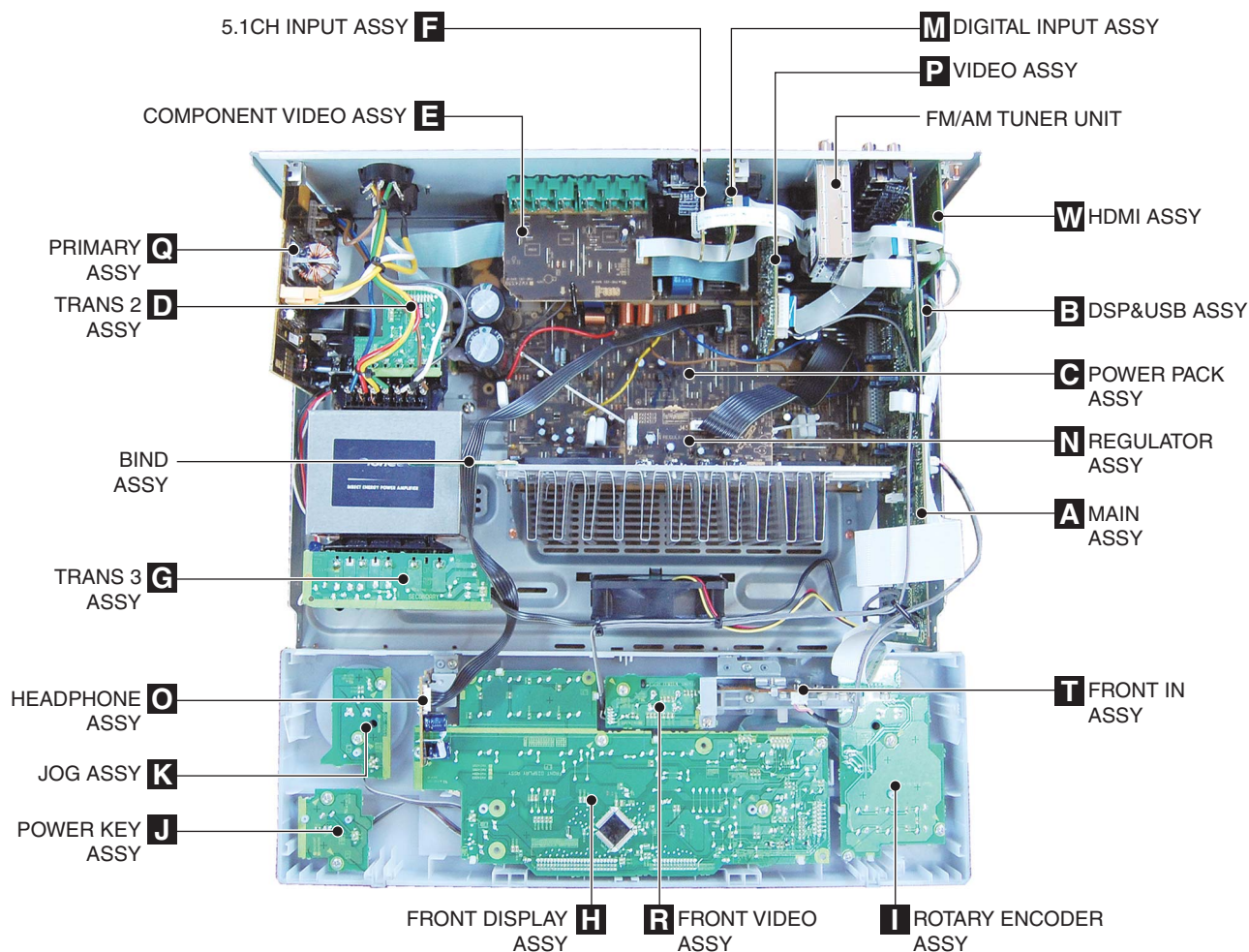

**NOTES:**

- Parts marked by "NSP" are generally unavailable because they are not in our Master Spare Parts List.
- The  $\triangle$  mark found on some component parts indicates the importance of the safety factor of the part. Therefore, when replacing, be sure to use parts of identical designation.

Mark No.	Description	Part No.	Mark No.	Description	Part No.
<b>LIST OF ASSEMBLIES</b>					
	1..HDMI ASSY	AWX8966	NSP	1..AMP ASSY	XWK3349
	1..DSP&USB ASSY	AWX9164		2..POWER PACK ASSY	XWZ4326
NSP	1..COMPLEX ASSY	XWK3336		2..TRANS 2 ASSY	XWZ4335
	2..FRONT DISPLAY ASSY	XWZ4284		2..TRANS 3 ASSY	XWZ4337
	2..ROTARY ENCODER ASSY	XWZ4286		2..COMPONENT VIDEO ASSY	XWZ4339
	2..POWER KEY ASSY	XWZ4287		2..5.1CH INPUT ASSY	XWZ4341
	2..JOG ASSY	XWZ4289		2..BIND ASSY	XWZ4344
	2..VIDEO ASSY	XWZ4292	1..MAIN ASSY		XWK3359
	2..DIGITAL INPUT ASSY	XWZ4299	1..FRONT IN ASSY		XWK3366
	2..FRONT VIDEO ASSY	XWZ4300	1..FM/AM TUNER UNIT		AXX7170
	2..PRIMARY ASSY	XWZ4302			
	2..REGULATOR ASSY	XWZ4317			
	2..HEADPHONE ASSY	XWZ4321			

# 4. BLOCK DIAGRAM

## 4.1 OVERALL WIRING CONNECTION DIAGRAM (VSX-918V)

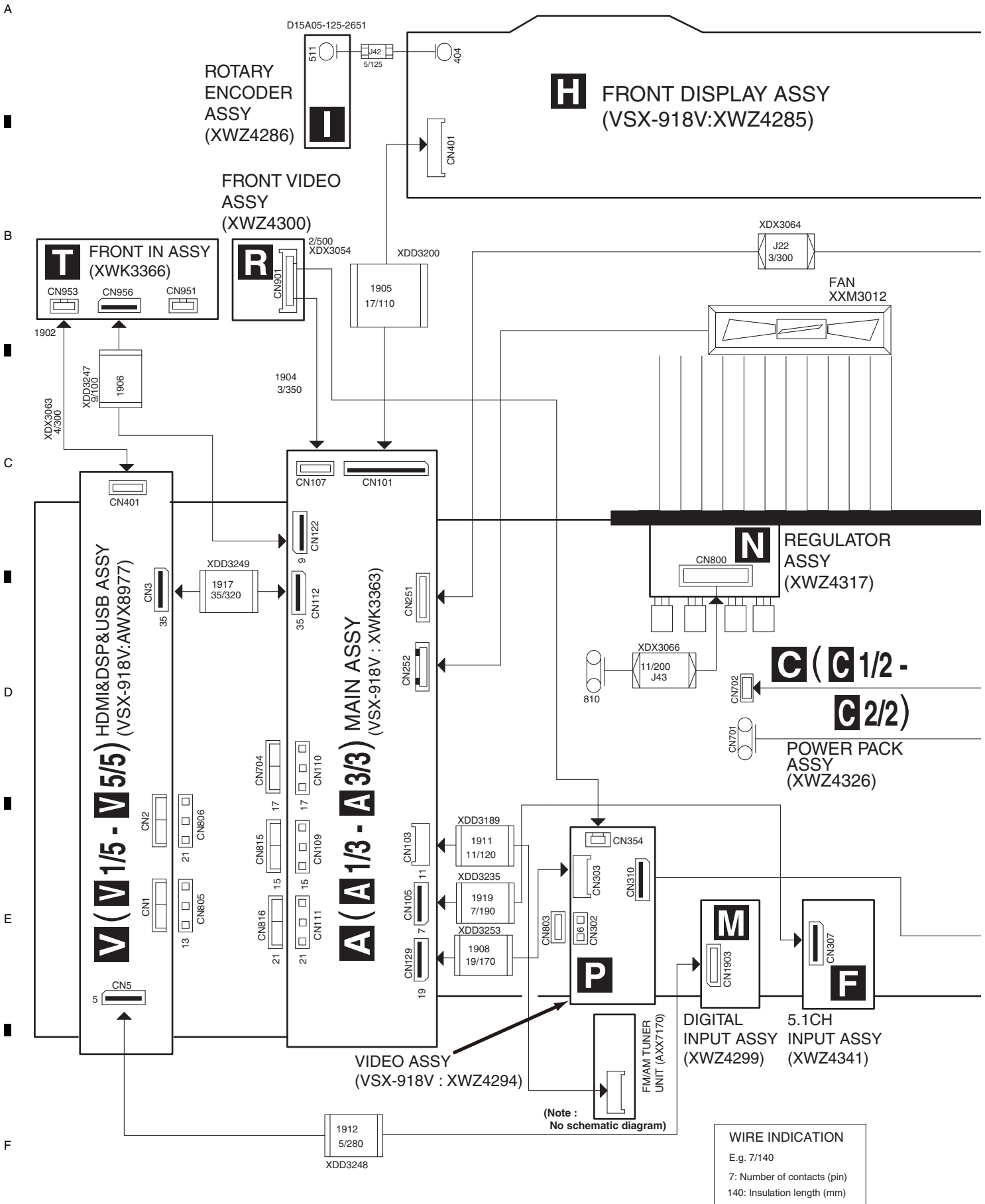

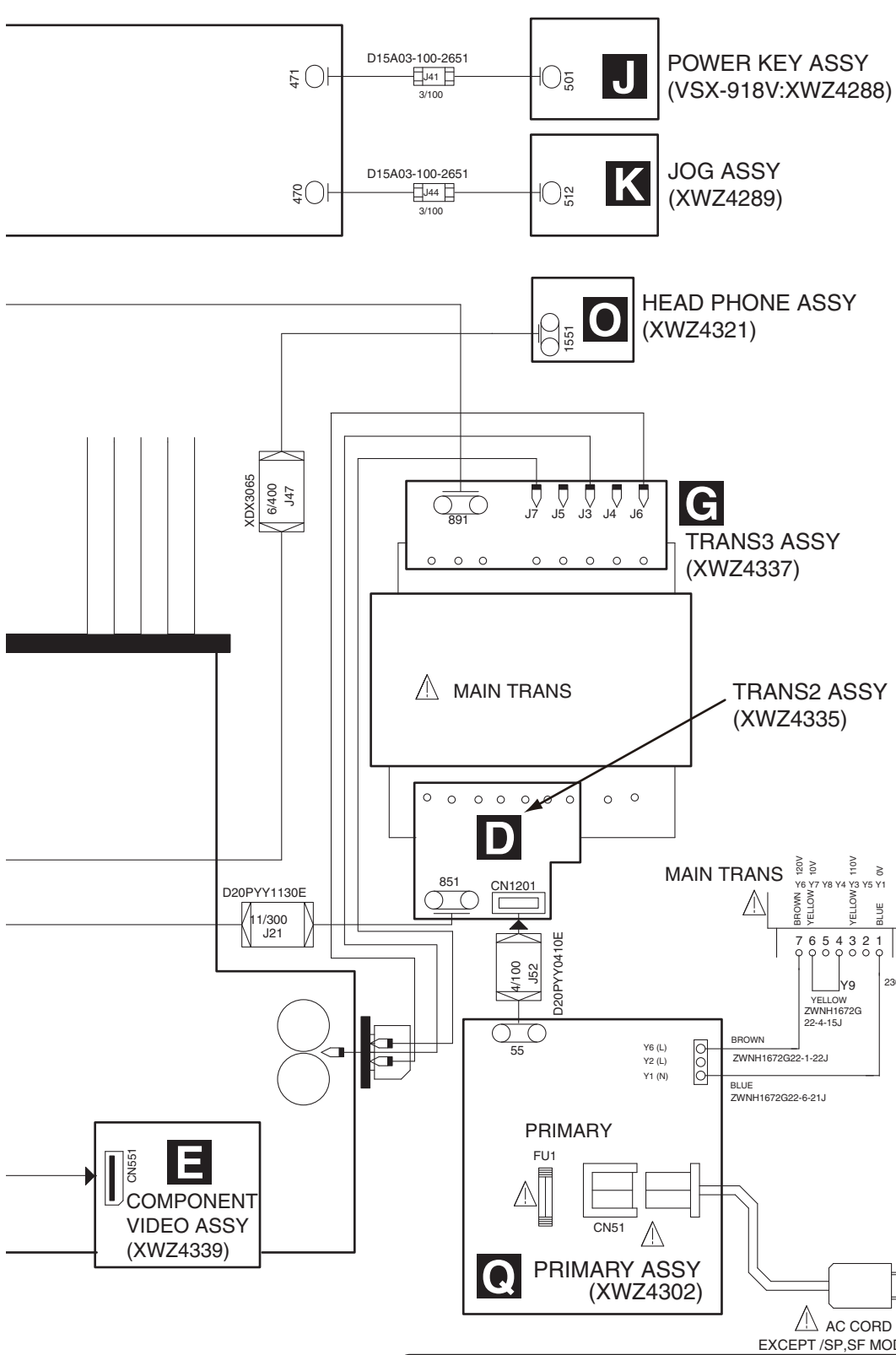

- B'B-PH-K-S PH CONNECTOR
- B'B-EH EH CONNECTOR
- 1.0mm FFC
- 1.25mm FFC
- 1.25mm REVERSE FFC
- 2.0mm FLAT CABLE
- 1.5mm FLAT CABLE
- BOARD IN
- 1.0mm FFC CONNECTOR
- 1.25mm FFC CONNECTOR(L)
- 1.25mm FFC CONNECTOR
- 2.0mm CABLE HOLDER
- 1.5mm CABLE HOLDER
- 2.0mm CABLE CONNECTOR
- 2.0mm BOARD to BOARD SOCKET
- 2.0mm BOARD to BOARD PLUG
- 1.25mm BOARD to BOARD SOCKET
- 1.25mm BOARD to BOARD PLUG
- AC CODE SOCKET
- AC CODE CONNECTOR

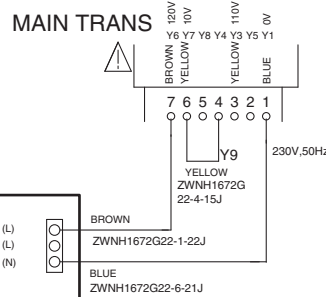

- When ordering service parts, be sure to refer to "EXPLODED VIEWS and PARTS LIST" or "PCB PARTS LIST".
- The ⚠ mark found on some component parts indicates the importance of the safety factor of the part. Therefore, when replacing, be sure to use parts of identical designation.
- : The power supply is shown with the marked box.

## 4.2 OVERALL WIRING CONNECTION DIAGRAM (VSX-818V)

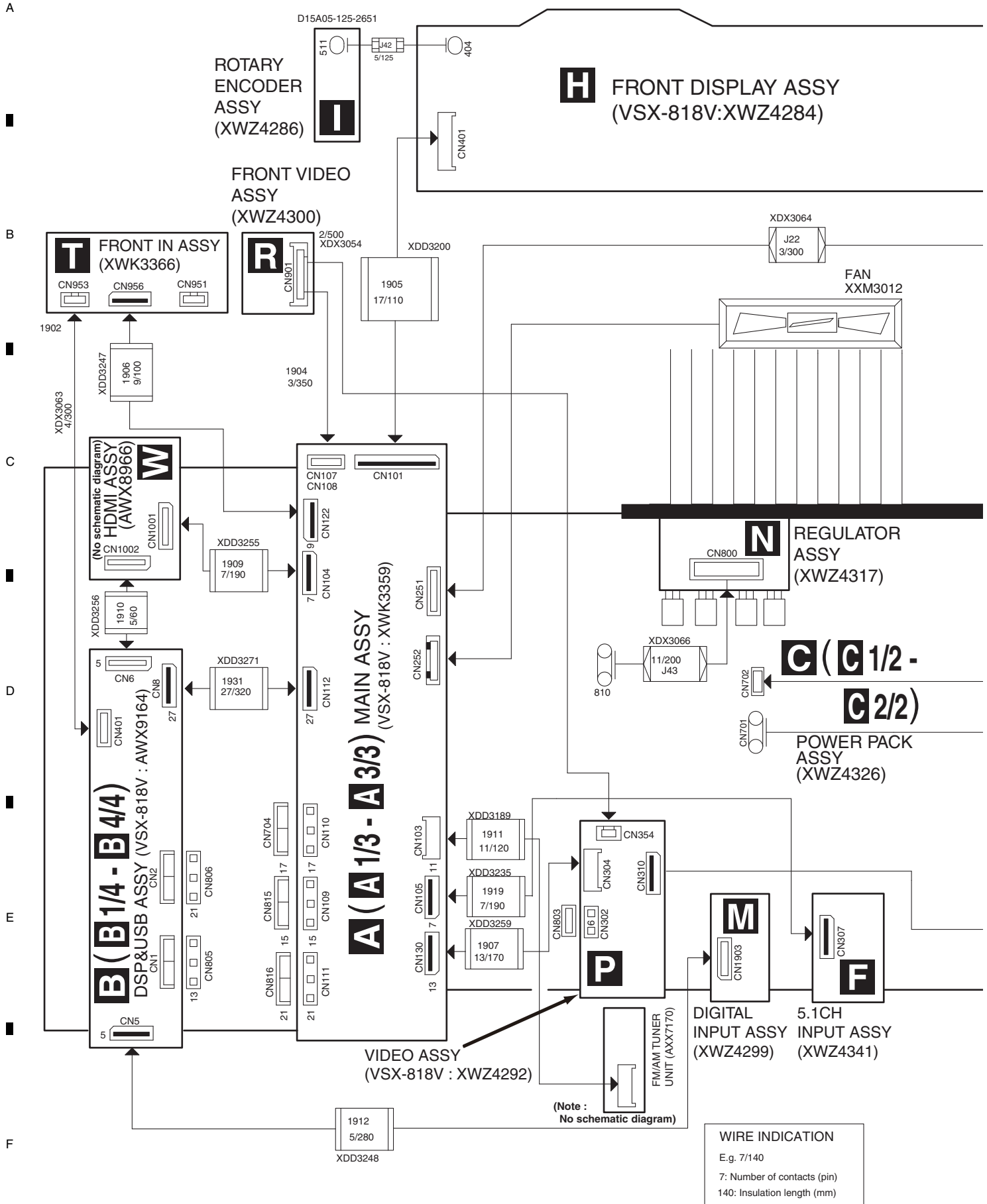

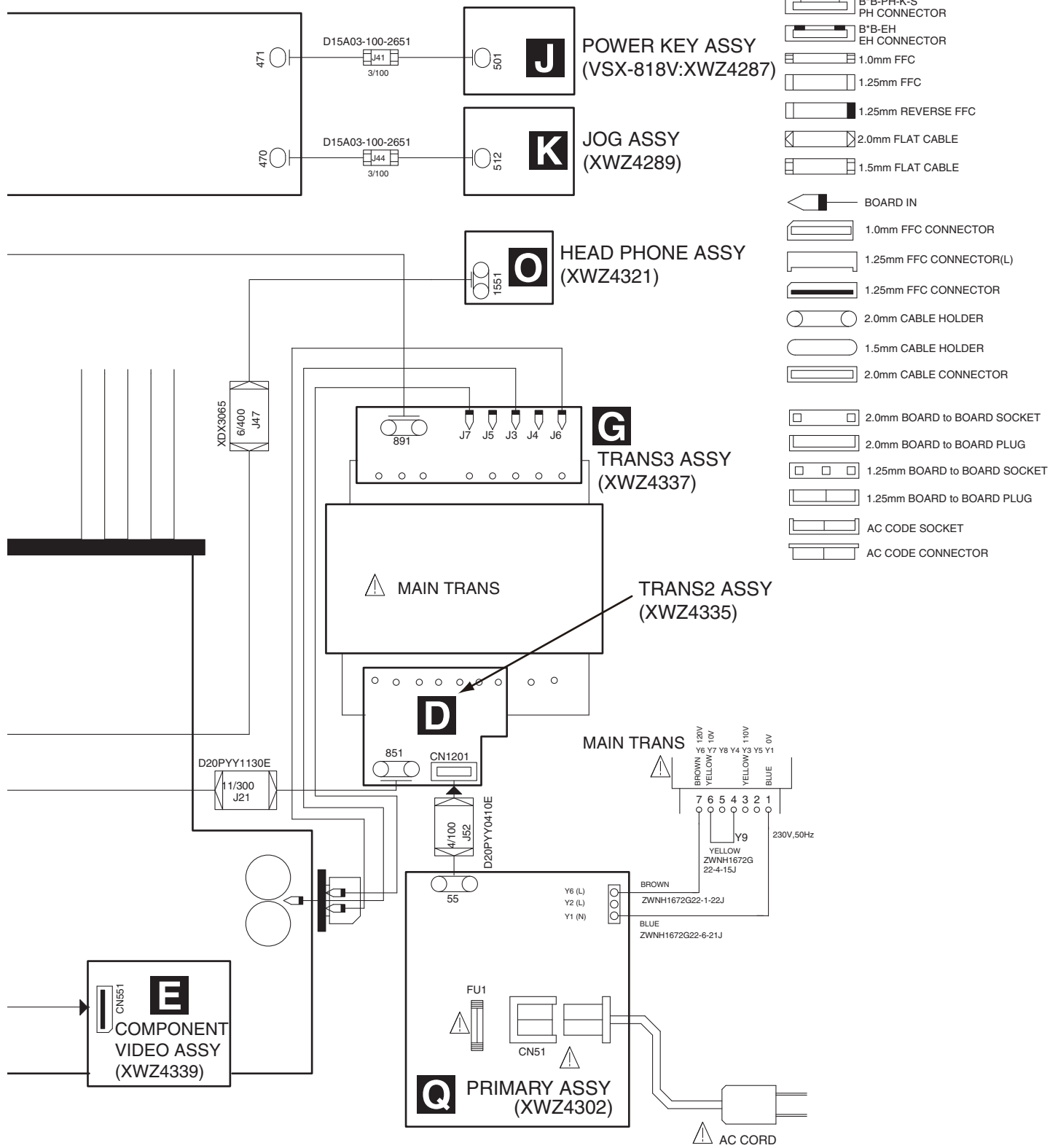

- When ordering service parts, be sure to refer to "EXPLODED VIEWS and PARTS LIST" or "PCB PARTS LIST".
- The ⚠ mark found on some component parts indicates the importance of the safety factor of the part. Therefore, when replacing, be sure to use parts of identical designation.
-  : The power supply is shown with the marked box.

# 4.3 BLOCK DIAGRAM (VSX-918V)

## BLOCK DIAGRAM FOR VSX-918V

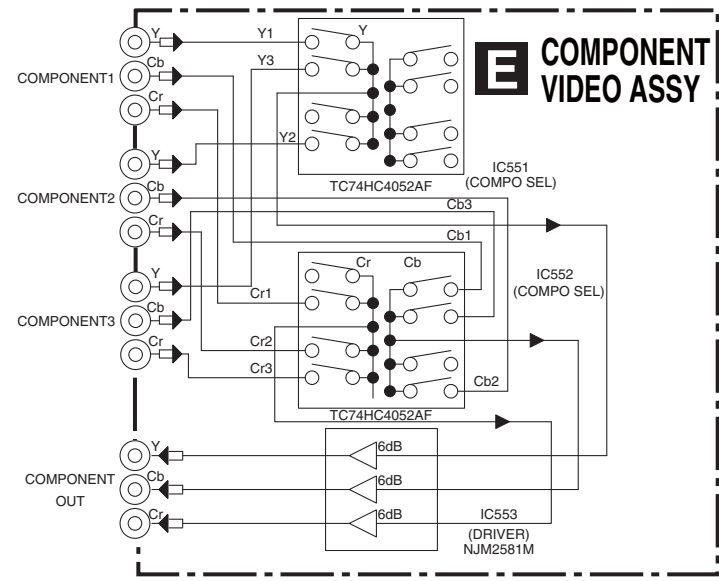
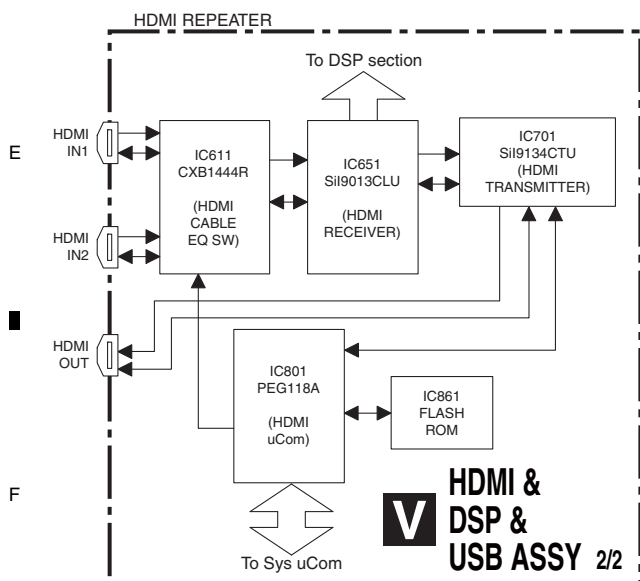
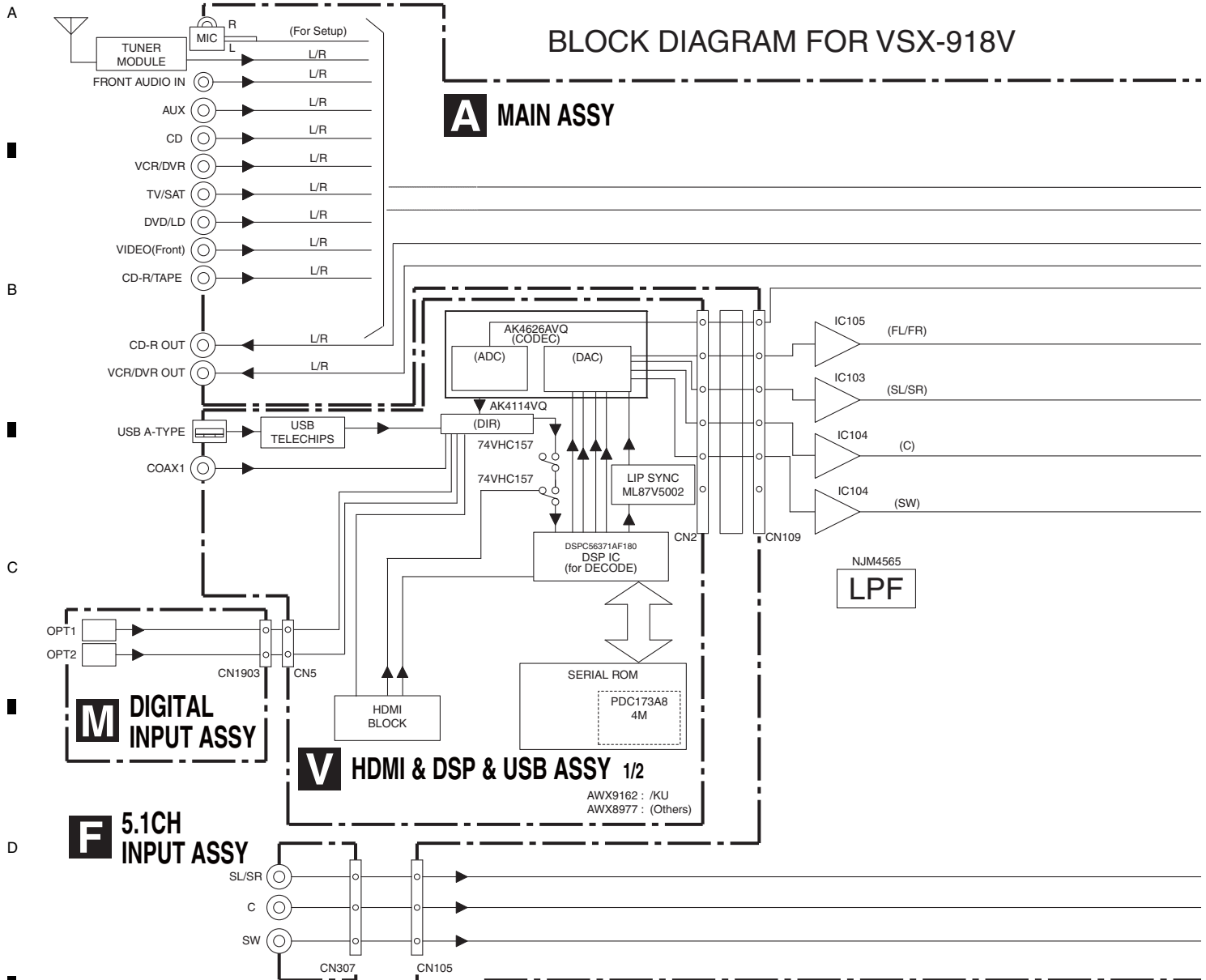

# HEAD PHONE ASSY

▶ : VIDEO SIGNAL FLOW  
▶ : AUDIO SIGNAL FLOW

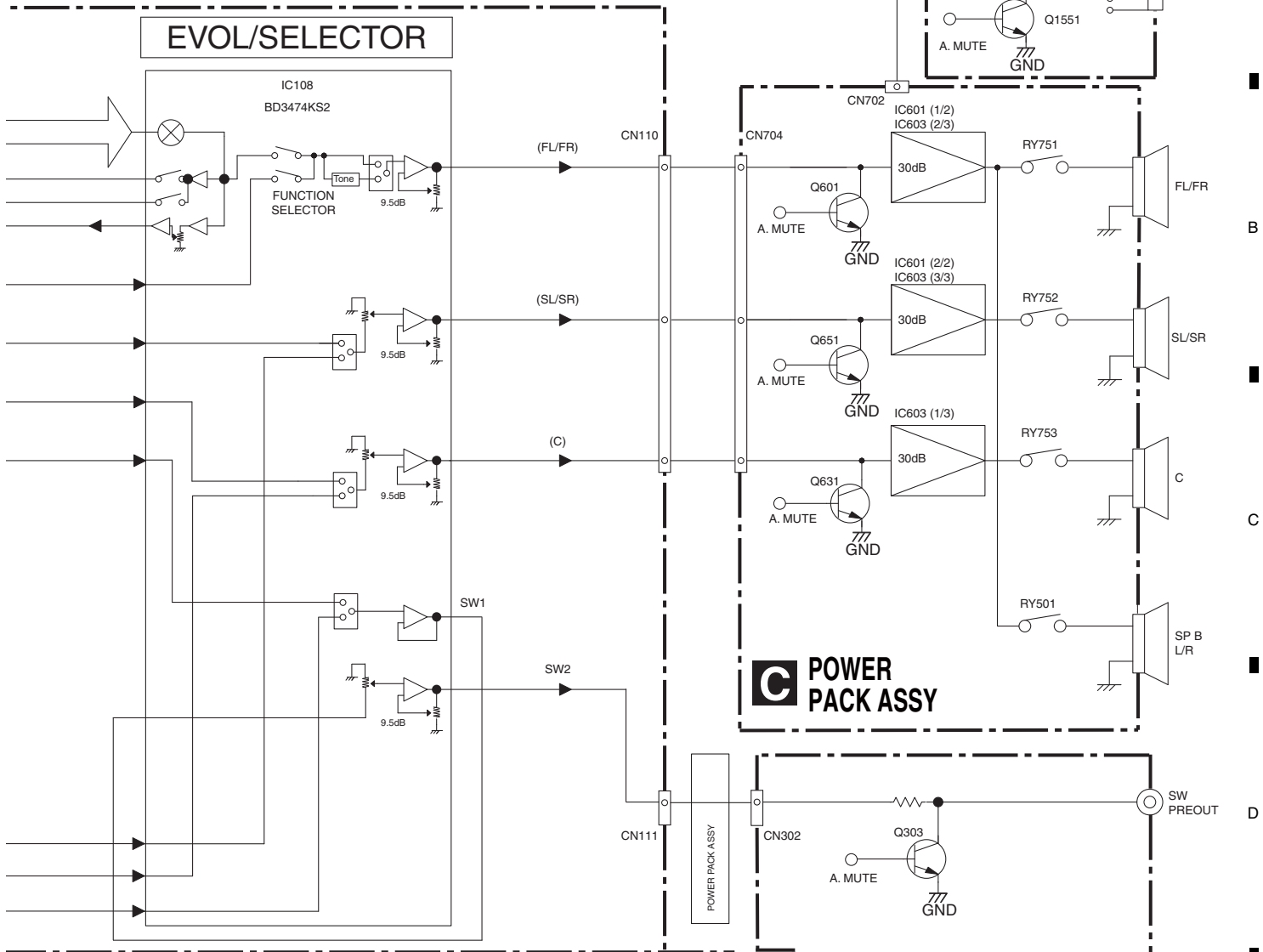

# VIDEO ASSY

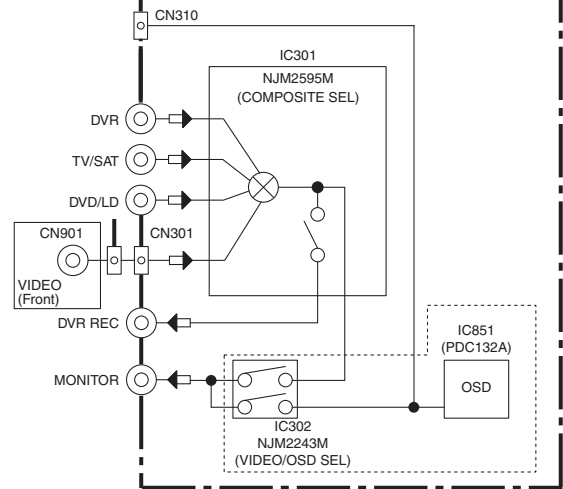

# 4.4 BLOCK DIAGRAM (VSX-818V)

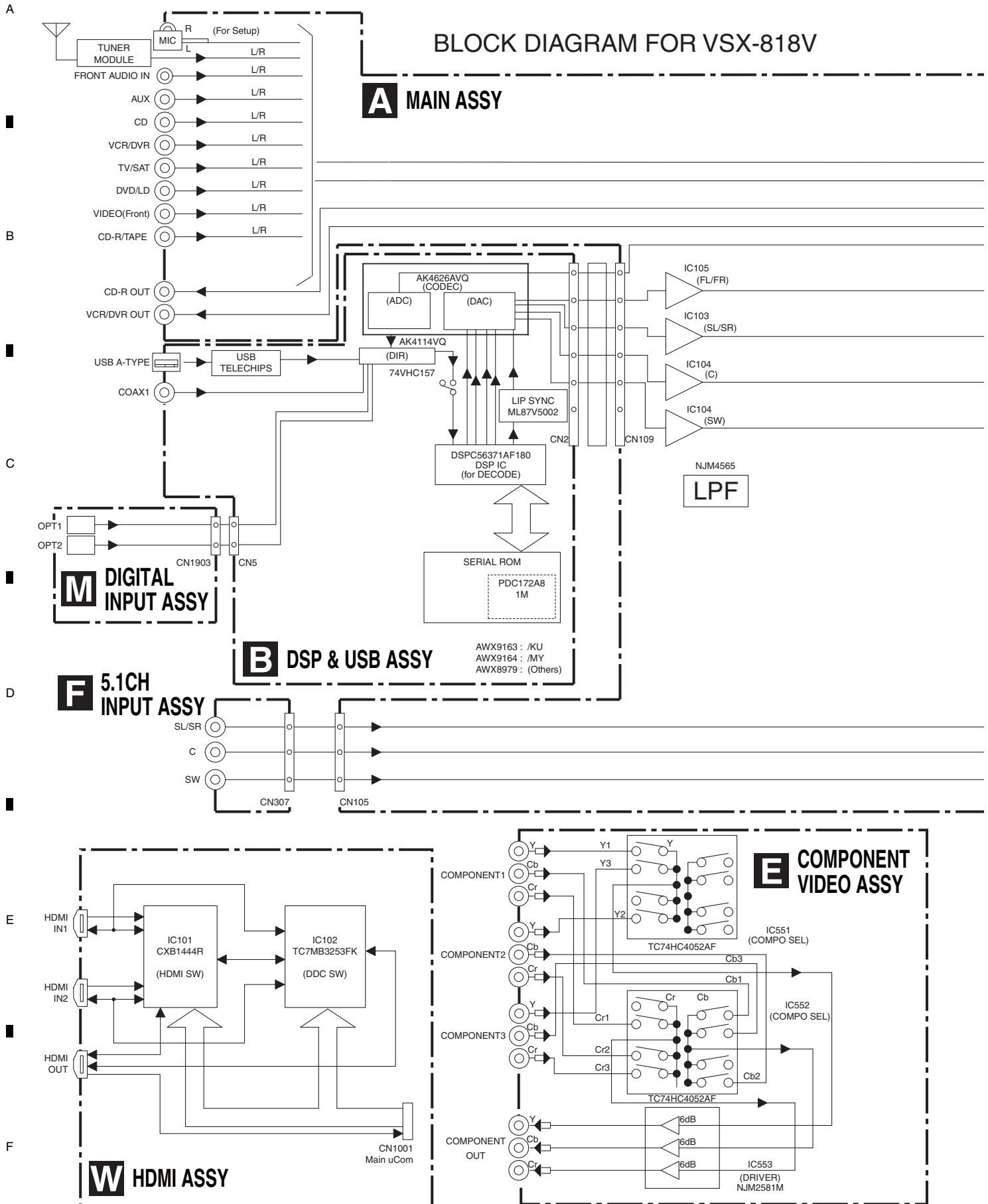

# HEAD PHONE ASSY

□ : VIDEO SIGNAL FLOW  
 → : AUDIO SIGNAL FLOW

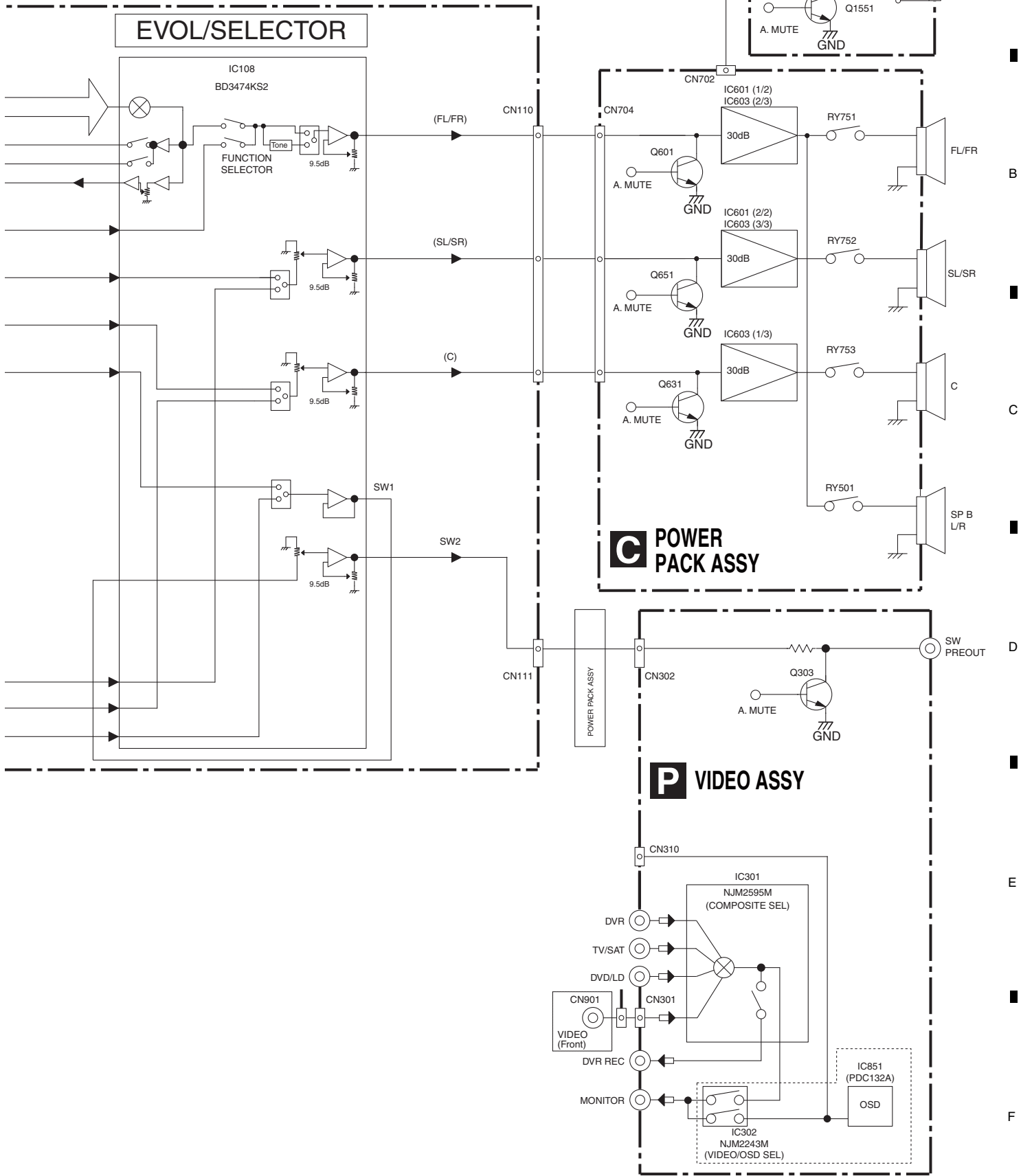

# 4.5 DSP BLOCK DIAGRAM

## Block Diagram (DSP portion)

**B** DSP&USB ASSY  
(VSX-818V : AWX9164)

**V** HDMI&DSP&USB ASSY  
(VSX-918V:AWX8977)

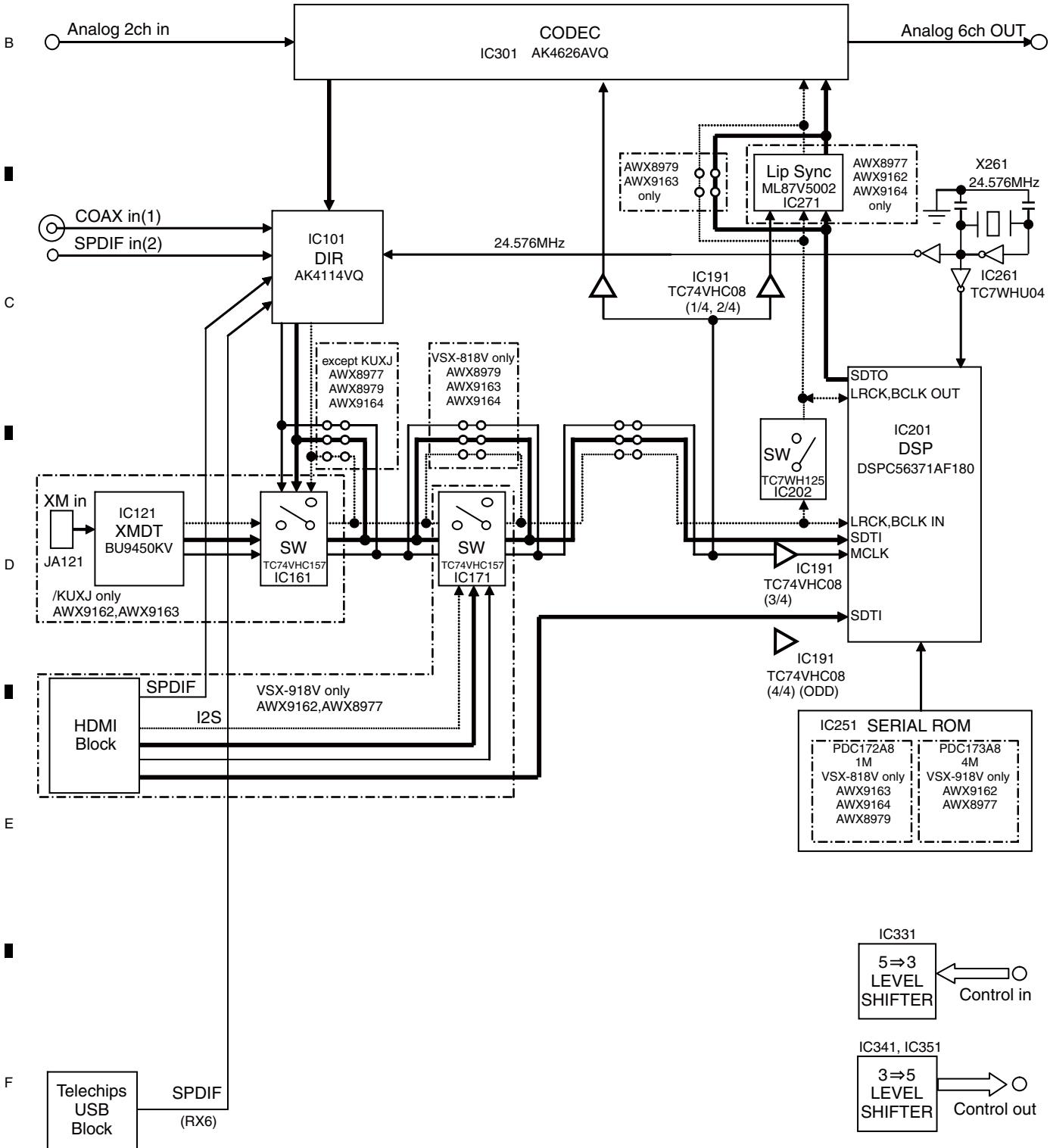
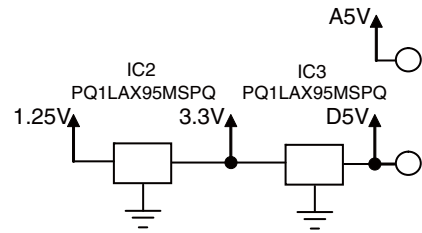

# 4.6 HDMI BLOCK DIAGRAM

VSX-918V HDMI&DSP&USB ASSY  
HDMI Block Diagram

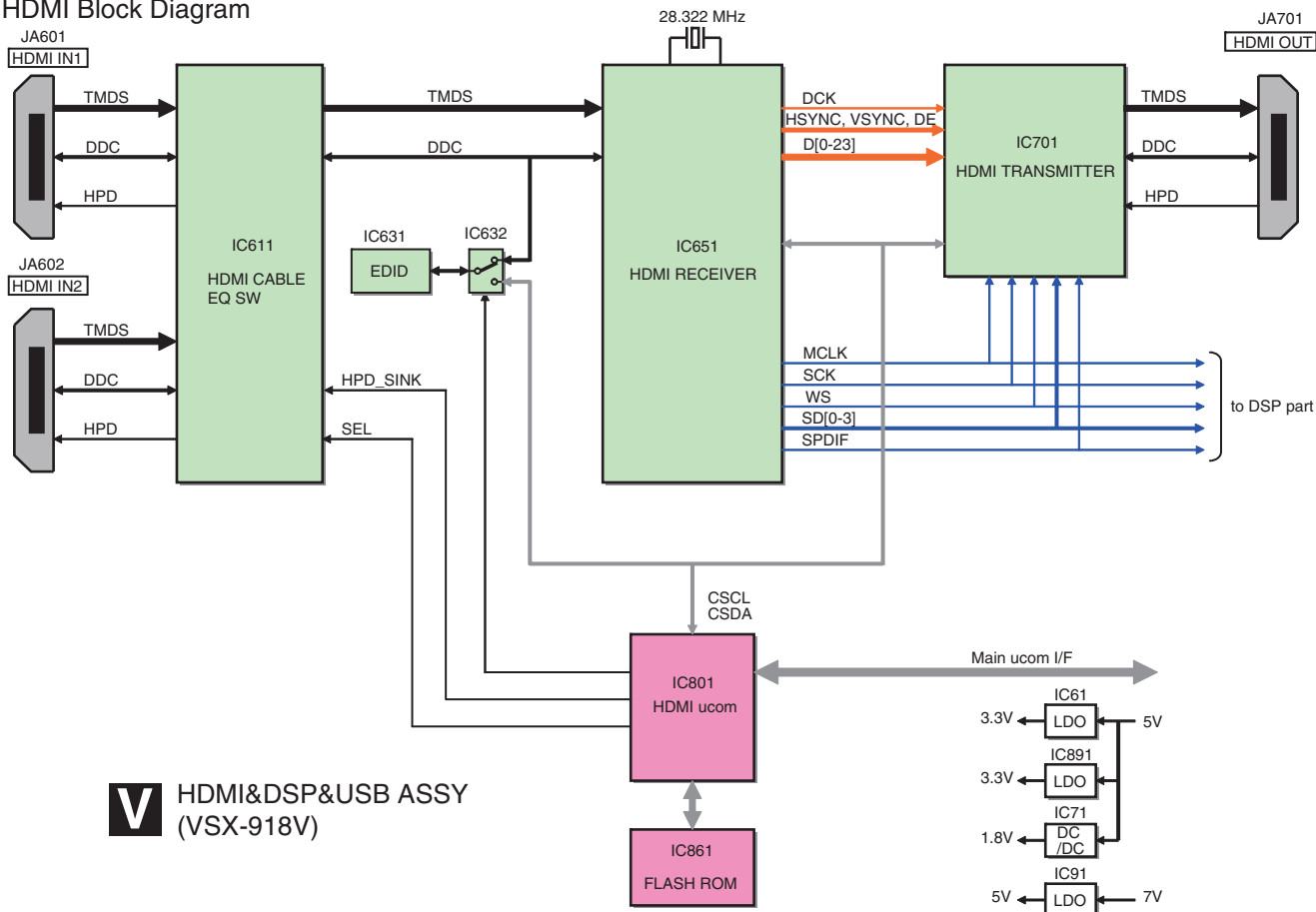

**V** HDMI&DSP&USB ASSY (VSX-918V)

VSX-818V HDMI ASSY(Pass through SW) Block Diagram

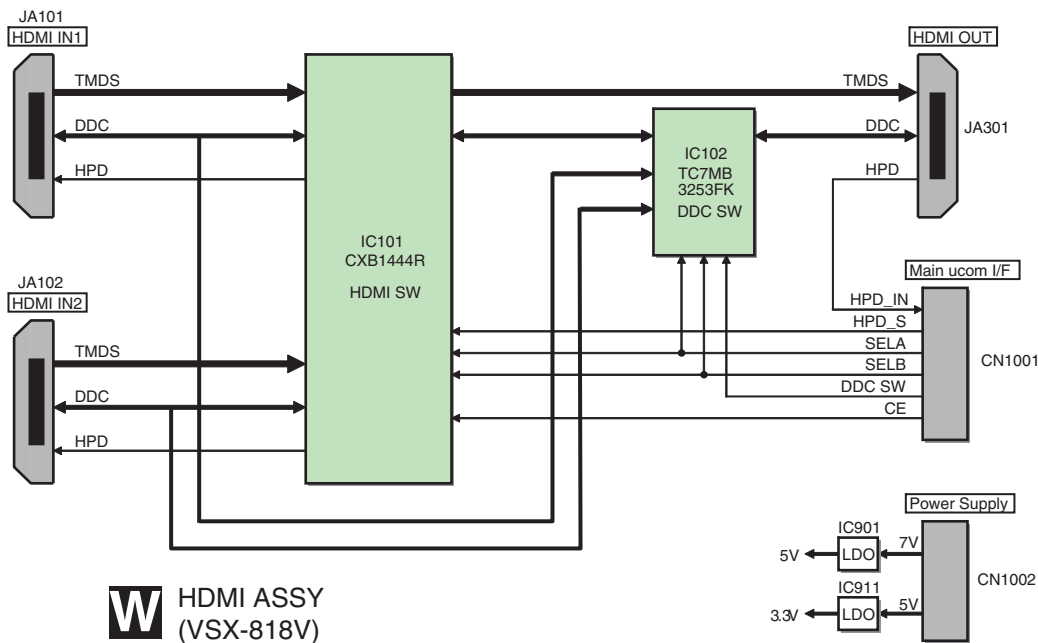

**W** HDMI ASSY (VSX-818V)

# 4.7 USB BLOCK DIAGRAM

## Block Diagram (USB portion)

**B** DSP&USB ASSY  
(VSX-818V : AWX9164)

**V** HDMI&DSP&USB ASSY  
(VSX-918V:AWX8977)

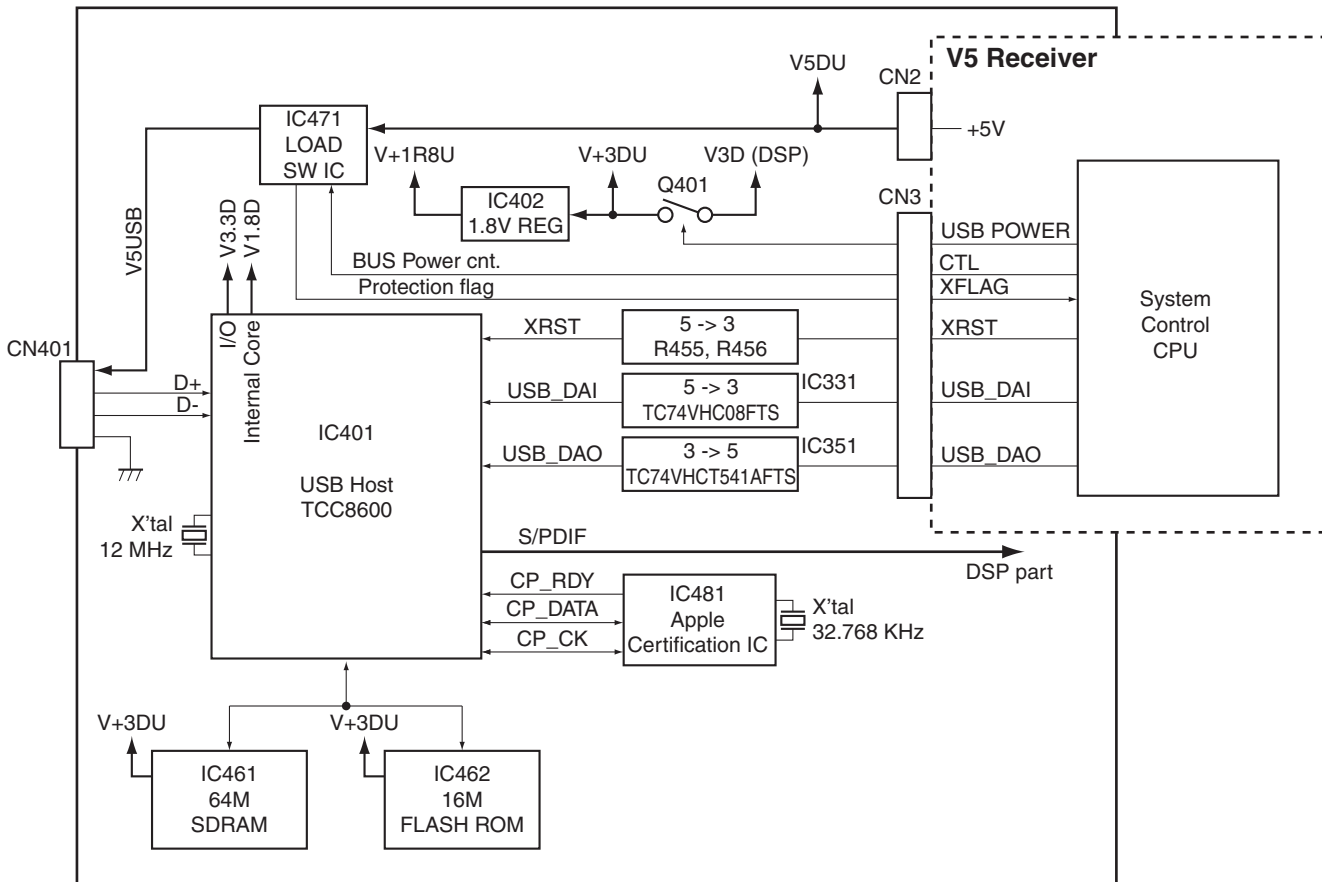

# 5. DIAGNOSIS

## 5.1 DIAGNOSIS FLOWCHART

### [1] DSP TROUBLESHOOTING

#### ■ Troubleshooting for all destination

- When a sound is not out in the multi-CH signal playback mode or surround mode with the COAX, OPT, USB or HDMI input. (SurroundBack is not output by setting.)
- Suppose CR to be normal contact and that is not damaged.
- This shows failure analysis of DSP Block.

#### Step 0: Preliminary confirmation

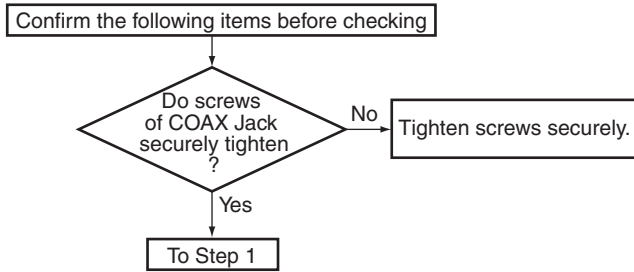

#### Step 1: MUTE pin

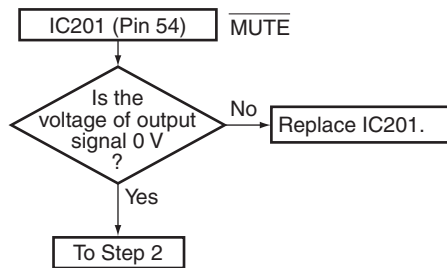

#### Step 2: BtoB connector and FFC

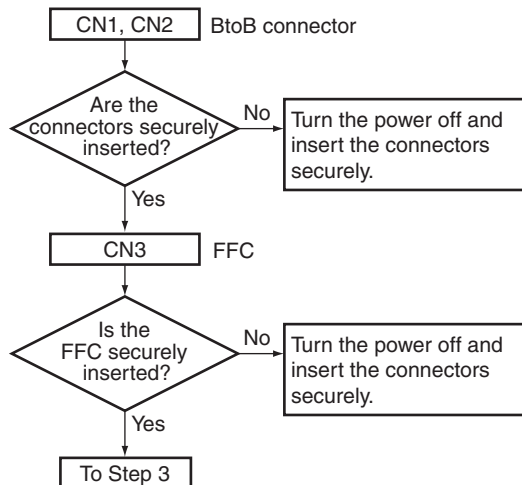

#### Step 3: Regulator IC

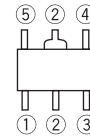
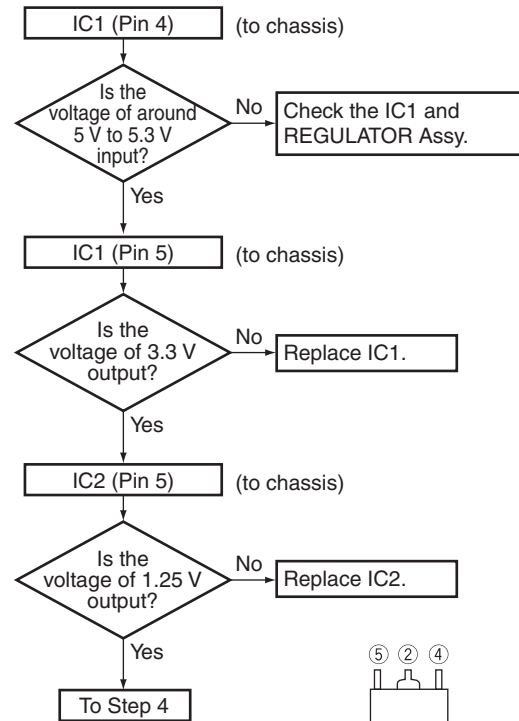

Part shape and Pin arrangement of IC1 and IC2

#### Step 4: 3 V to 5 V conversion

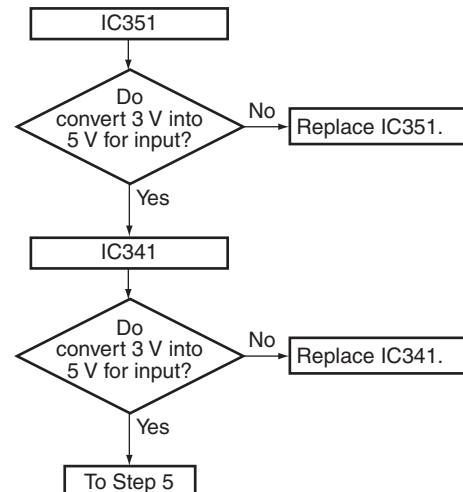

### Step 5: 5 V to 3 V conversion

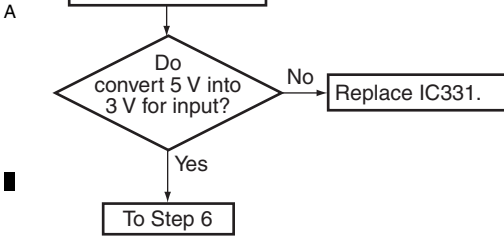

### Step 6: X'tal

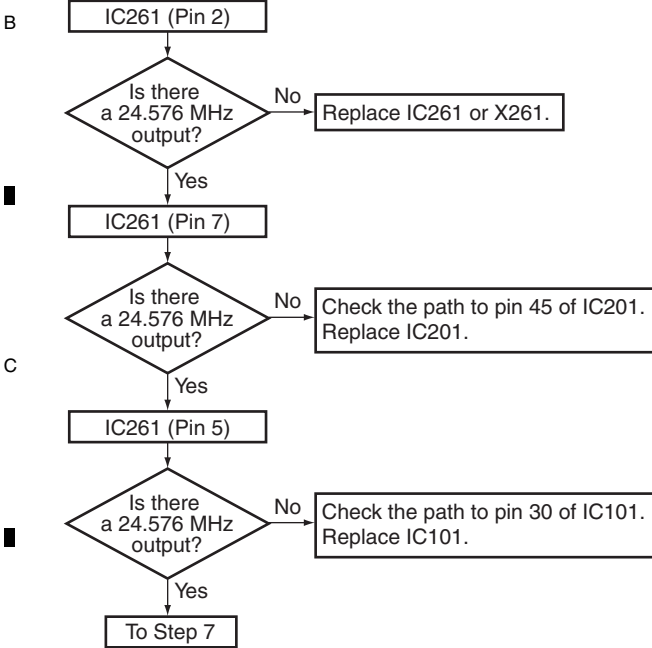

### Step 7

When the COAX, OPT or USB is input, go to Step 7-1.  
When the HDMI is input, go to Step 7-2.

### Step 7-1: DIR

Check that the S/PDIF signal is output.  
Check that changes by pulling out and inserting the digital input lines.

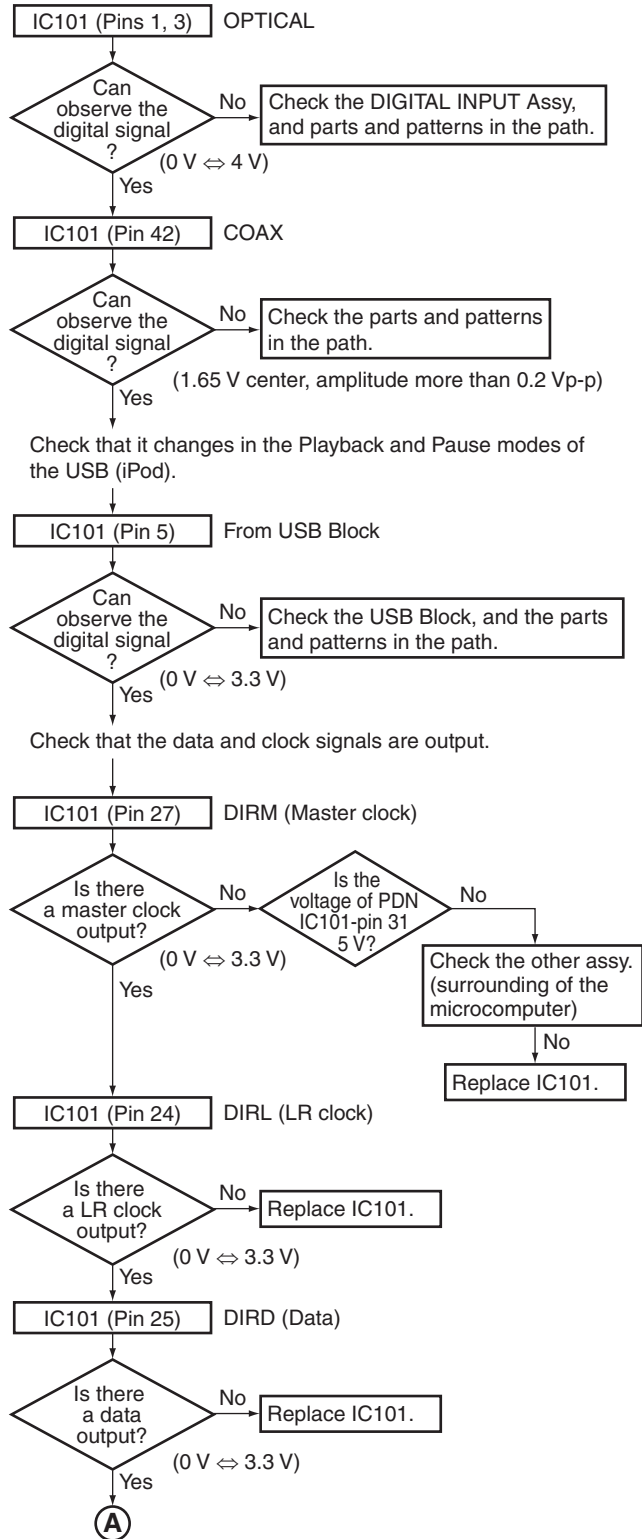

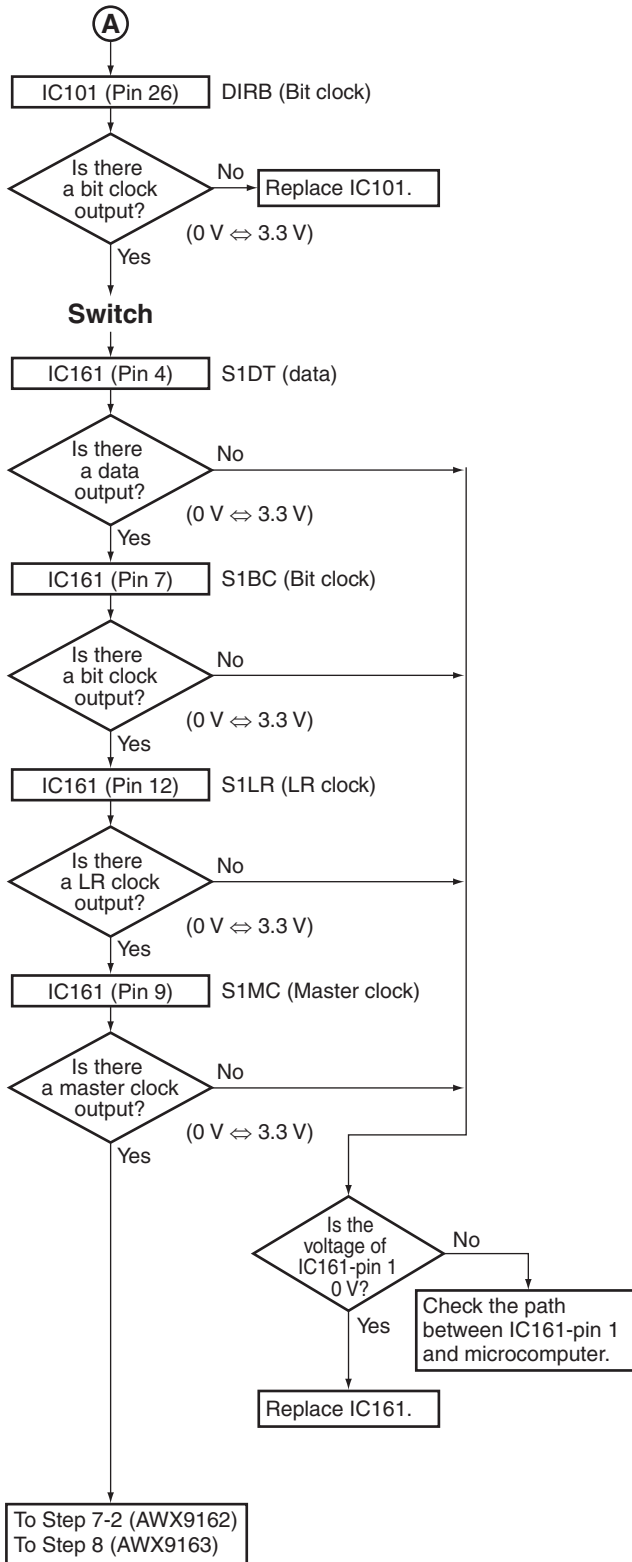

### Step 7-2 (AWX9162 only)

Check that the data and clock signals are output.

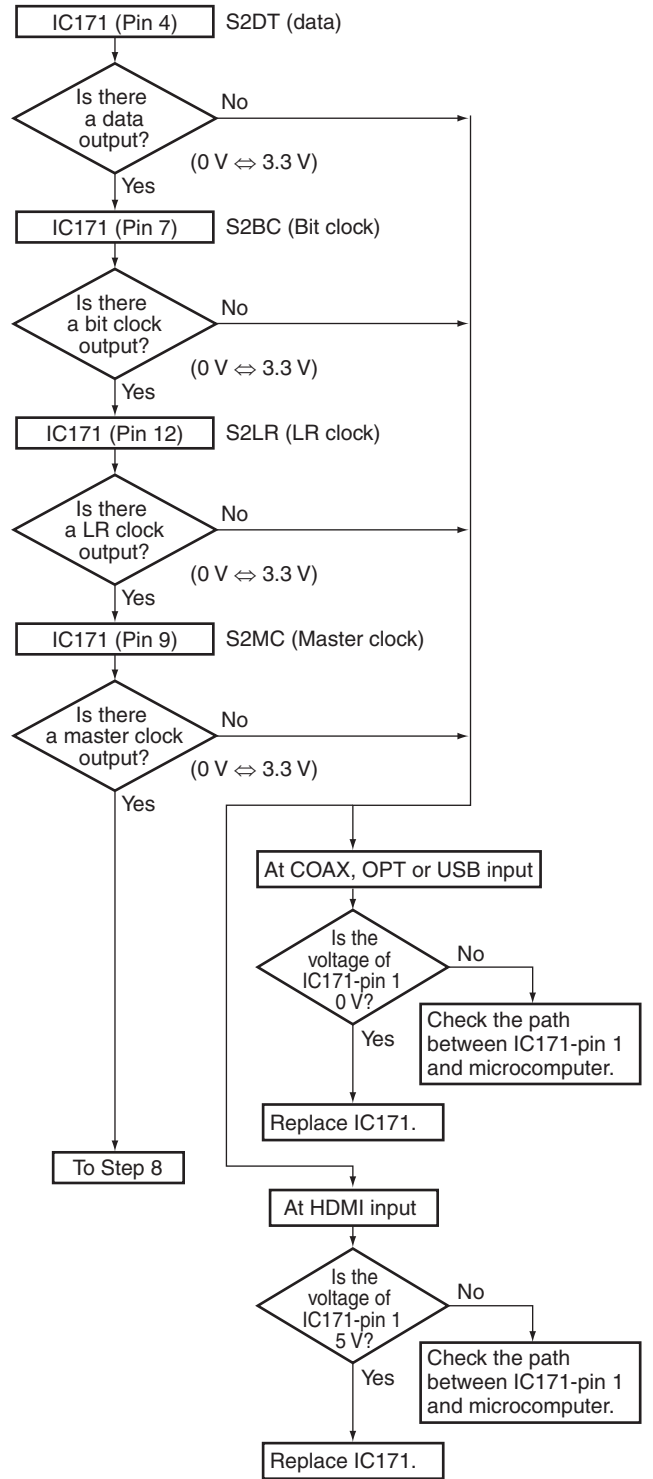

### Step 8: DSP output (digital)

Digital output of each CH when inputting the digital signal with audio.

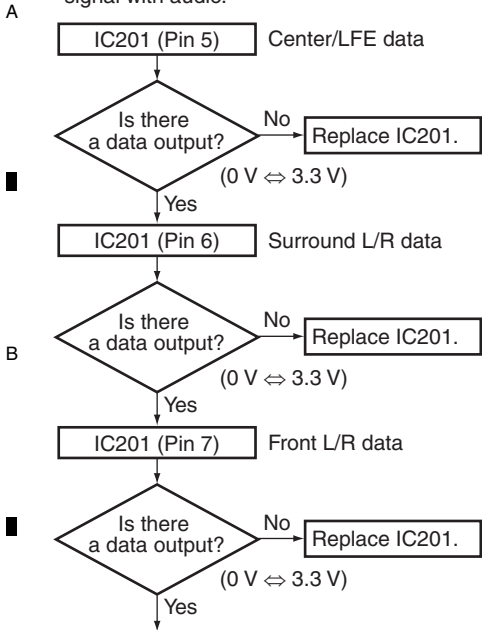

Digital output of each CH when inputting the digital signal (-∞ dB (no audio)).

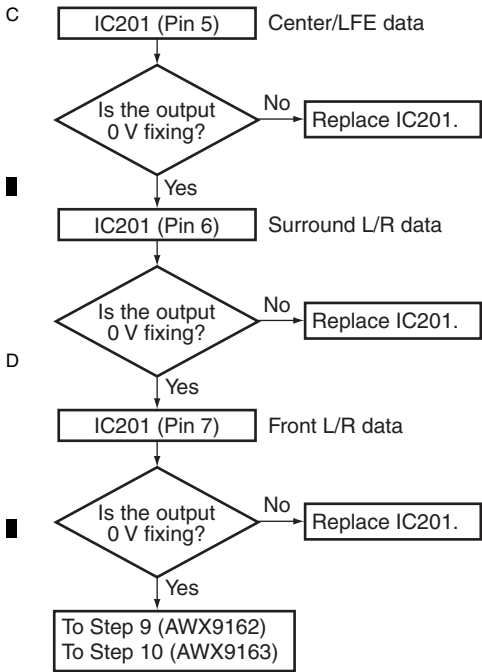

### Step 9: LIPSYNC output (Digital) (AWX9162 only)

Check that the data and clock signals are output.

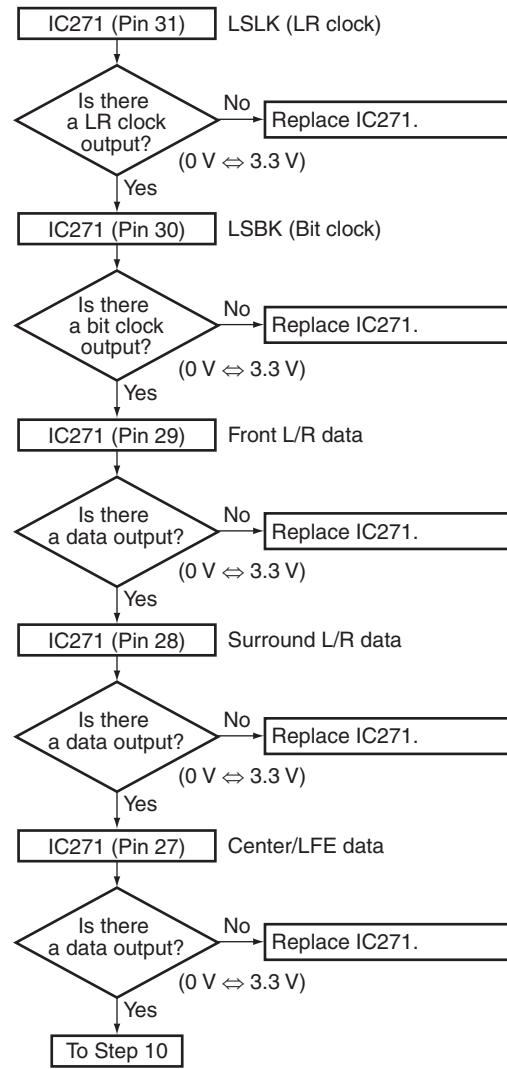

## Step 10: Codec output (analog)

Analog output of each CH when inputting the digital signal with audio.

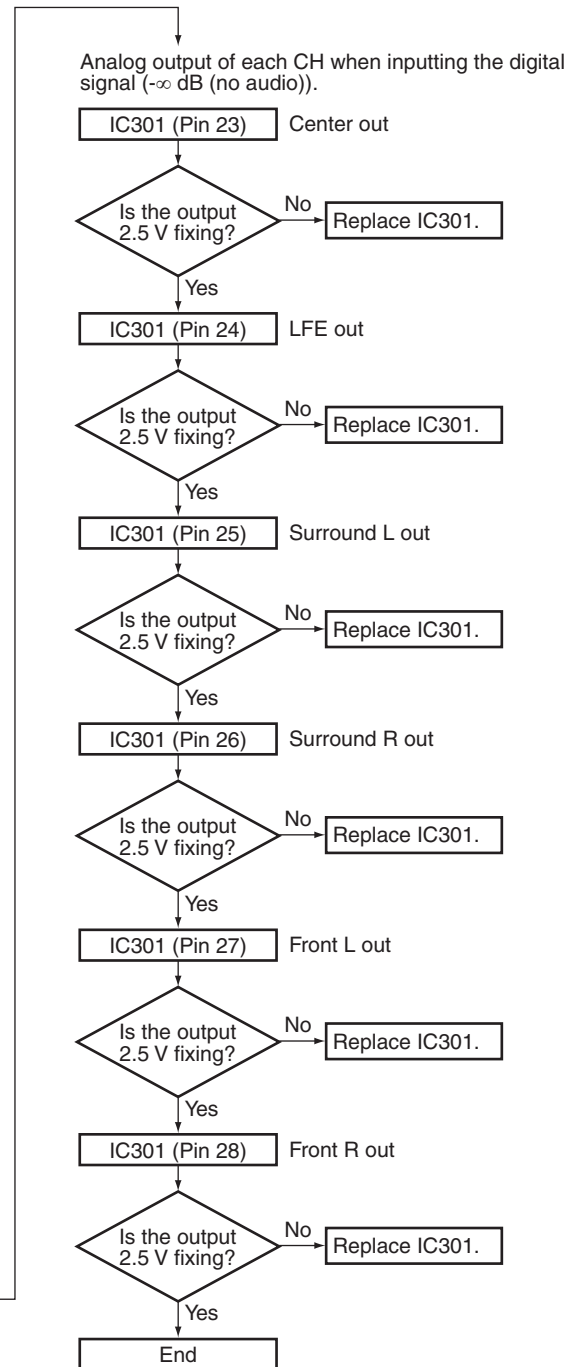
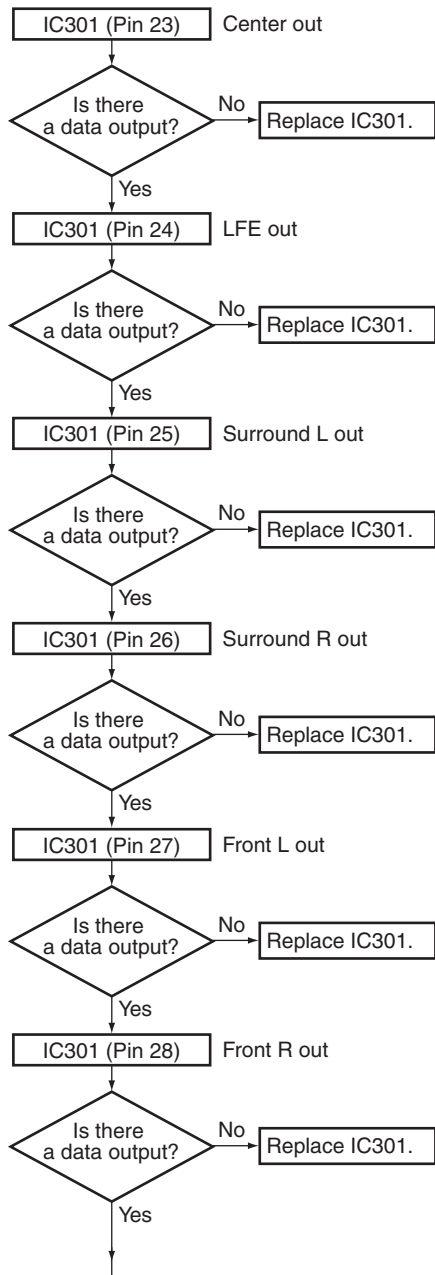

A

B

C

D

E

F

### Troubleshooting in the MCACC mode

- When the MCACC mode is turned on (SurroundBack is not output by setting.)
- Suppose CR to be normal contact and that is not damaged.
- This shows failure analysis of DSP Block.

#### Step 0: Preliminary confirmation

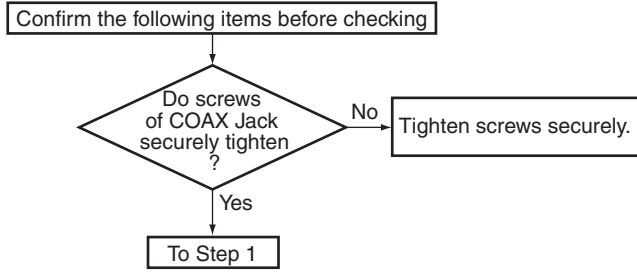

#### Step 1: MUTE pin

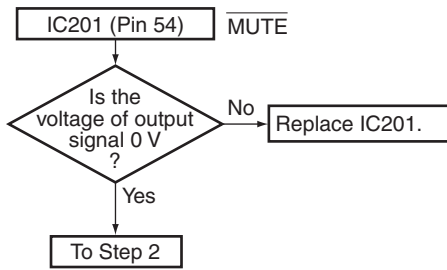

#### Step 2: BtoB connector and FFC

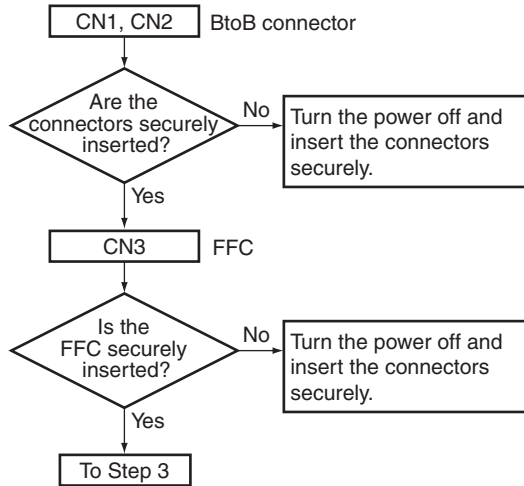

#### Step 3: Regulator IC

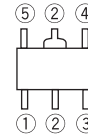
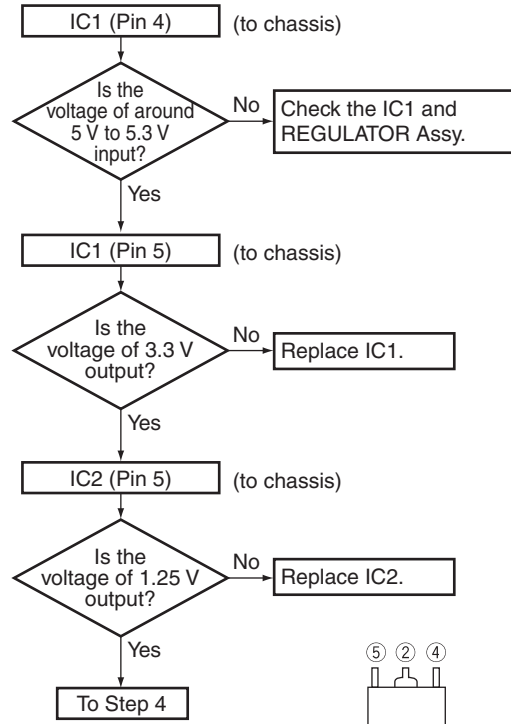

Part shape and Pin arrangement of IC1 and IC2

#### Step 4: 3 V to 5 V conversion

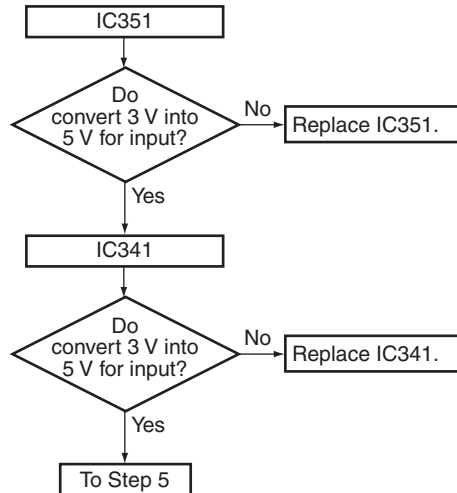

### Step 5: 5 V to 3 V conversion

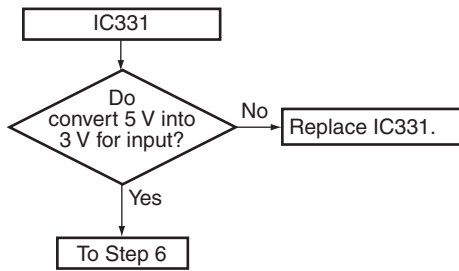

### Step 6: X'tal

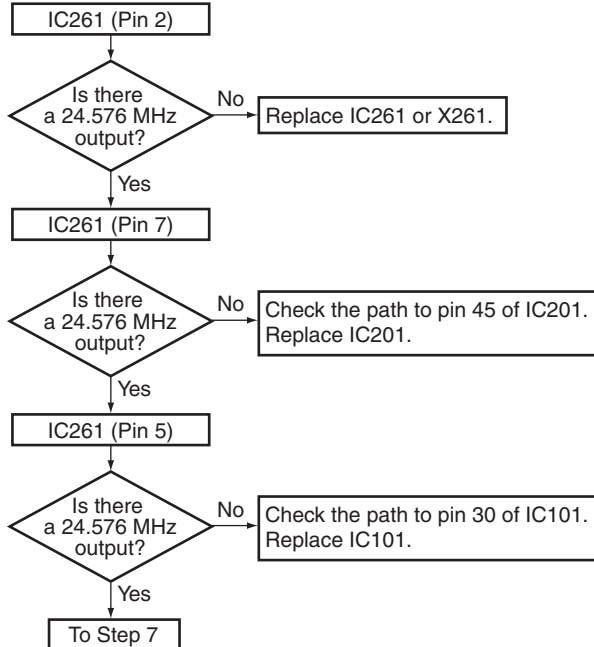

### Step 7: ROM

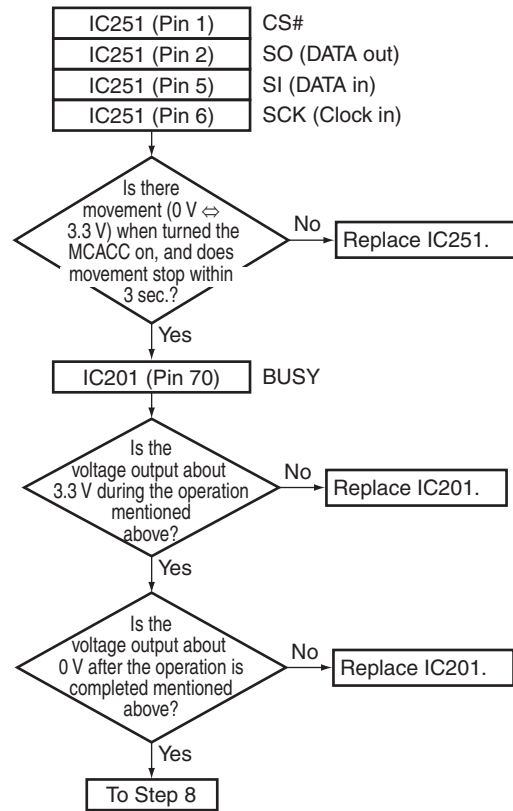

### Step 8: DSP output (digital)

Digital output when indicated each CH.

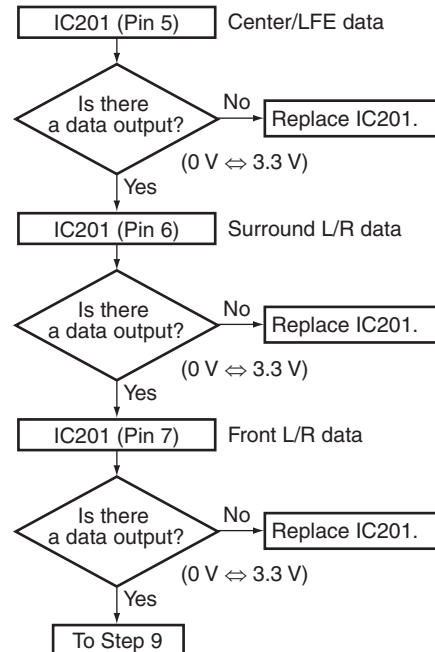

### Step 9: CODEC output (analog)

Analog output when indicated each CH.

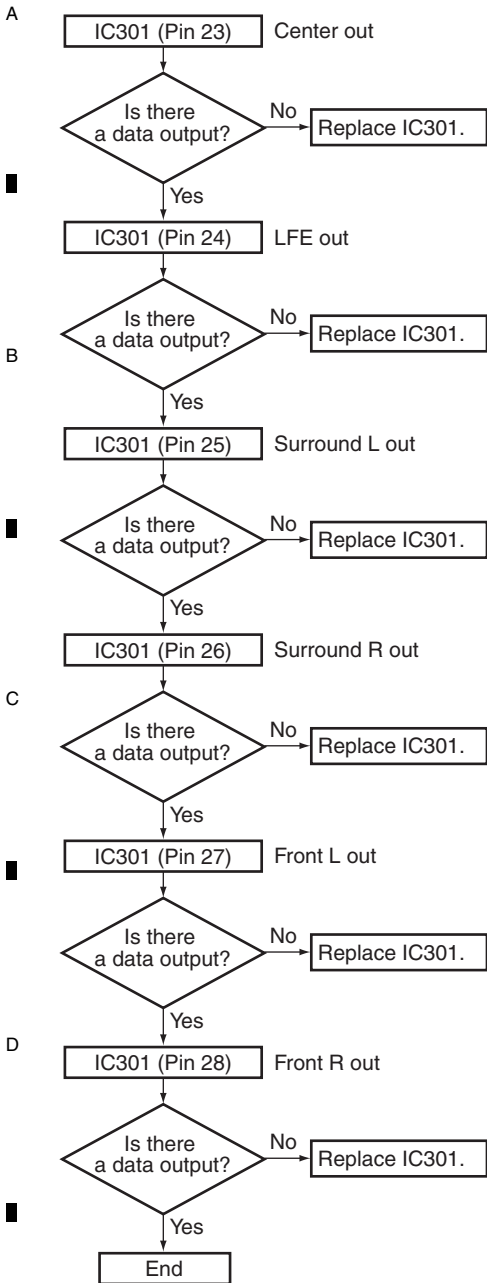

## [2] USB TROUBLESHOOTING

### Description of Error Indications

FL Display	Error Content	Possible causes and actions to be taken
USB ERROR1	Detection of overcurrent to a USB device	Overcurrent (500 mA or more) is consumed at the connected USB device. <ul style="list-style-type: none"> <li>Some USB devices, such as a portable HDD, need more current than that this unit supplies. (Use the AC adaptor for the connected USB device.)</li> <li>The USB power is short-circuited.</li> </ul>
USB ERROR2	Detection of a medium not supported	A USB device that this unit does not support (other than the Mass Storage Class) is connected (such as a mouse, printer, or digital camera). <ul style="list-style-type: none"> <li>Connect a mass storage class USB device.</li> </ul>
USB ERROR3	Communication error with the system microcomputer	Communication between TCC8600-00X-EA-UG (IC401) and PEG467/469A (IC9001) failed. <ul style="list-style-type: none"> <li>Defective connection (connectors) inside this unit</li> <li>See STEP 3 of Troubleshooting.</li> </ul>

If a USB ERR message lights in the display, try following the points below:

- Switch the receiver off, then on again.
- Reconnect the USB device with the receiver switched off.
- Select another input source (like DVD/BD), then switch back to USB.
- Use a dedicated AC adaptor (supplied with the device) for USB power.

If this doesn't remedy the problem, it is likely your USB device is incompatible.

### Operations when overcurrent to a USB device is detected

- (1) Overcurrent to a USB device is detected at the port for the microcomputer.
- (2) The power supply to the USB device is stopped.
- (3) Control of 5 V power is disabled at the port for the microcomputer.
- (4) Change of indications on the FL display

Flashes for 2 sec.

U:S:B: E:R:R:1



Lights up after flashing for 2 sec.

U:S:B: E:R:R:1

- (5) To supply power to the USB module again:

- Turn the power to the unit off then back on.
- Set the function setting to anything other than USB then back to USB.
- Press the USB play key on the remote control unit.

- (6) After overcurrent is detected, if the USB play key is pressed while the error indication is displayed, power supply to the USB module is restored. If overcurrent is no longer detected, the indications shown below are displayed (normal indication):

U:S:B:

In this state, flashing of "USB ERROR1" stops, but playback will not start. To start playback, press the USB play key again.

In the above case, if overcurrent is detected again, the above procedures 1 through 4 are repeated.

### In a case where a medium not supported is connected

- (1) Change of indications on the FL displays

Flashes for 2 sec.

U:S:B: E:R:R:2



Lights up after flashing for 2 sec.

U:S:B: E:R:R:2

If overcurrent is detected before detection of a non-supported medium, the error indication "USB ERROR1" remains, as the power supply to the USB module is stopped.

### On supported media

The formats of supported media that can be played back on this unit are MP3, WMA, and AAC.

Some media in MPEG4 can also be played back. As AAC derives from MPEG4 codec, playback of media in AAC codec of MPEG4 is possible.

### ■ iPod Error Message

A When the abnormality occurred, the error messages are indicated.

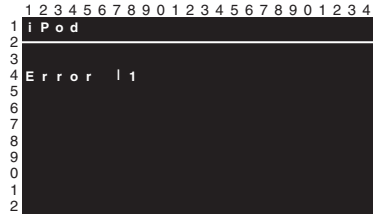
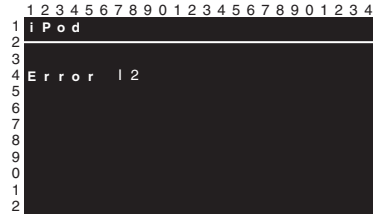
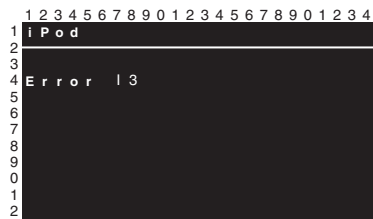
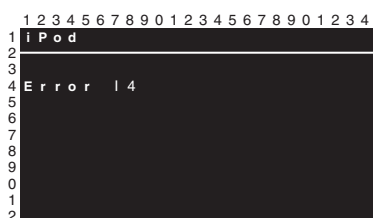
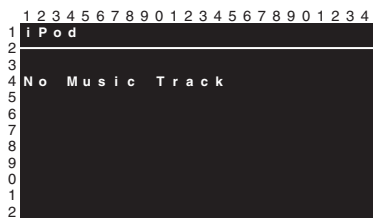
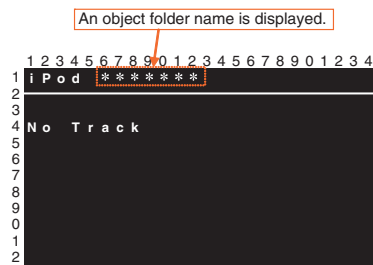
key sequence change	OSD display	FL display
<p><b>Error I1</b> Communication Error When the communication is not possible normally.</p> <p>[Procedure] Disconnect a connector once, then connect a connector surely again after the main menu of the iPod was displayed. Nevertheless, reset the iPod when the iPod does not operate normally.</p>		<p>(8-digit) <b>ERROR I1</b></p>
<p><b>Error I2</b> Protocol Ver.Error (in the Type 2 operation only) When a version of the iPod software is old.</p> <p>[Procedure] Update the iPod software to the newest version.</p>		<p>(8-digit) <b>ERROR I2</b></p>
<p><b>Error I3</b> Generation Error (in the Type 1 operation only) When the non-support model for the iPod Mode Type 1 was connected. When the non-support function will be executed. When a version of the iPod software is old.</p> <p>[Procedure] Change the iPod Mode to Type2. Update the iPod software to the newest version.</p>		<p>(8-digit) <b>ERROR I3</b></p>
<p><b>Error I4</b> Loading Error When there is no response from the iPod.</p> <p>[Procedure] The power is shut off once, then the unit back on. Reset the iPod. Update the iPod software to the newest version.</p>		<p>(8-digit) <b>ERROR I4</b></p>
<p><b>No Music Track</b> No Music Track Cautuion When a music track does not exist in the connected iPod.</p> <p>[Procedure] Transfer a music track to the iPod. When play a video track, turn on the iPod CTRL, and playback a track by operating the main unit of the iPod.</p>		<p>(8-digit) <b>NO MUSIC</b></p>
<p><b>No Track</b> No Music Track Cautuion When a track does not exist in the selected category</p> <p>[Procedure] Select another category.</p>	<p>An object folder name is displayed.</p> 	<p>(8-digit) <b>NO TRACK</b></p>

# USB Troubleshooting

\* VSX-918V (AWX8977)

\*\* VSX-818V (AWX9164)

## Step 1: Connectors

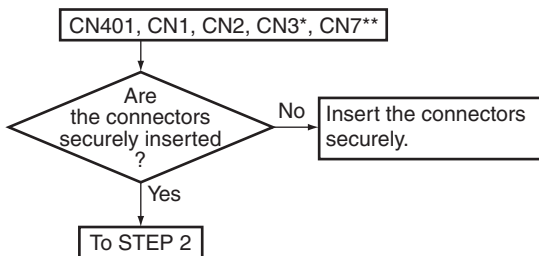

## Step 2: Power supply

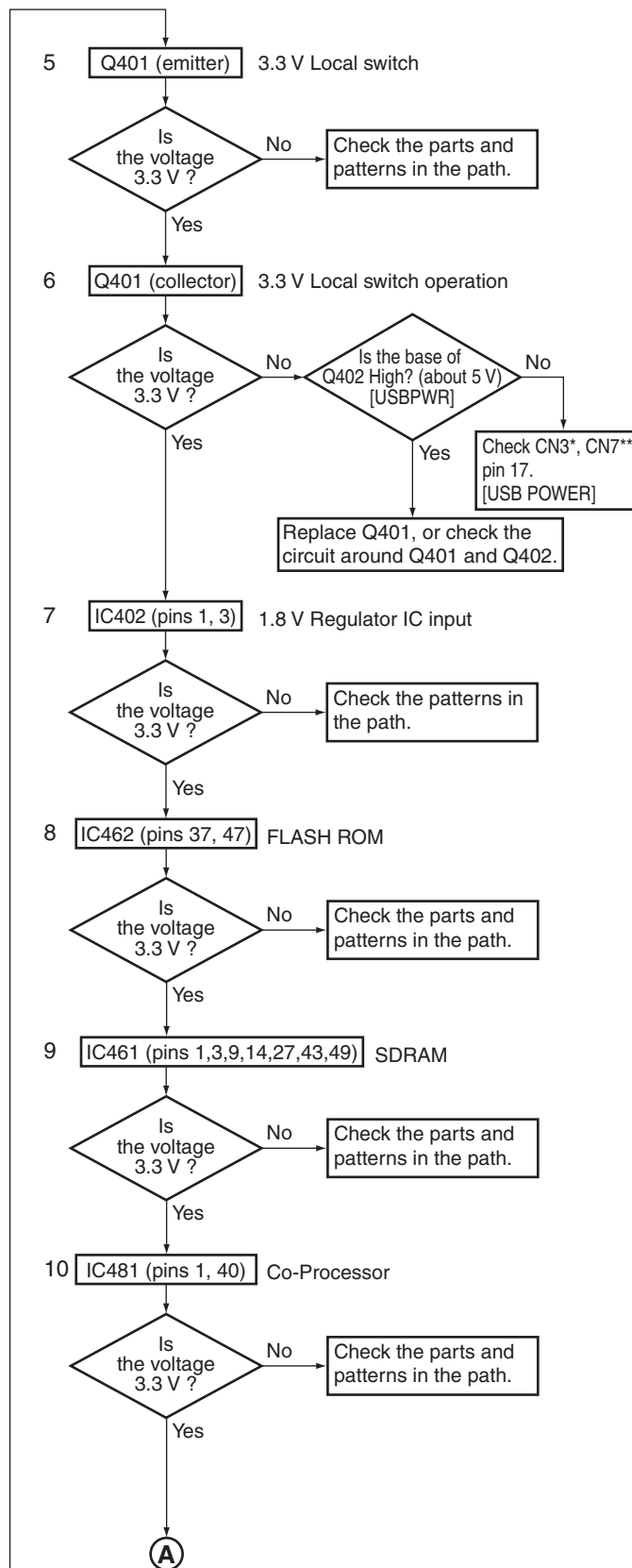
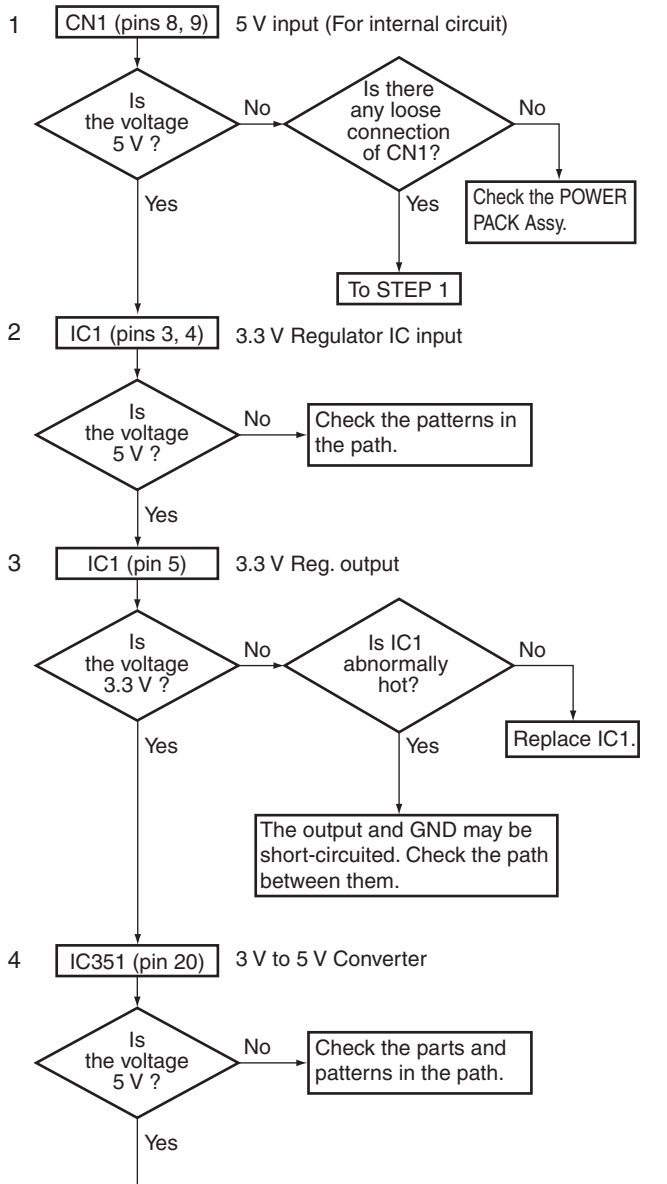

A

11 IC331 (pin 14) 5 V to 3 V Converter

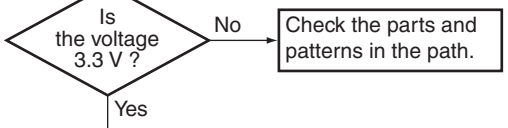

12 IC401 (pins 16, 33, 64, 76, 112) USB Media control IC

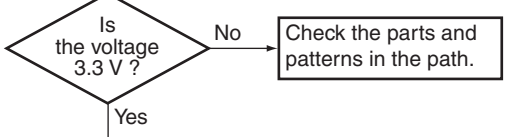

13 IC402 (pin 5) 1.8 V Regulator output

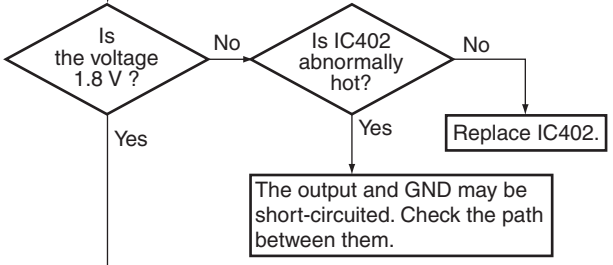

14 IC401 (pins 7, 24, 41, 71, 77, 87, 109, 119) USB Media control IC

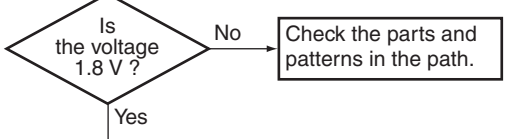

15 IC471 (pin 1) USB Power SW output

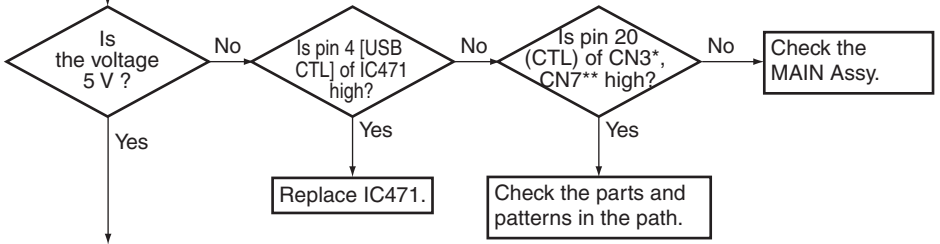

16 CN401 (pin 1) USB Bus power

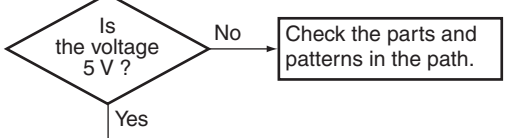

Power supply is OK. To STEP 3

\* VSX-918V (AWX8977)  
 \*\* VSX-818V (AWX9164)

### Step 3: Operation of USB Media control IC

**Note:** Please confirm it with the USB memory\*1 connected for the content.

\*1 iPod : This system is compatible with the audio of the following portable device in Jan. 2008.  
5G iPod, iPod nano, iPod nano 2G, iPod nano 3G, iPod classic, iPod touch

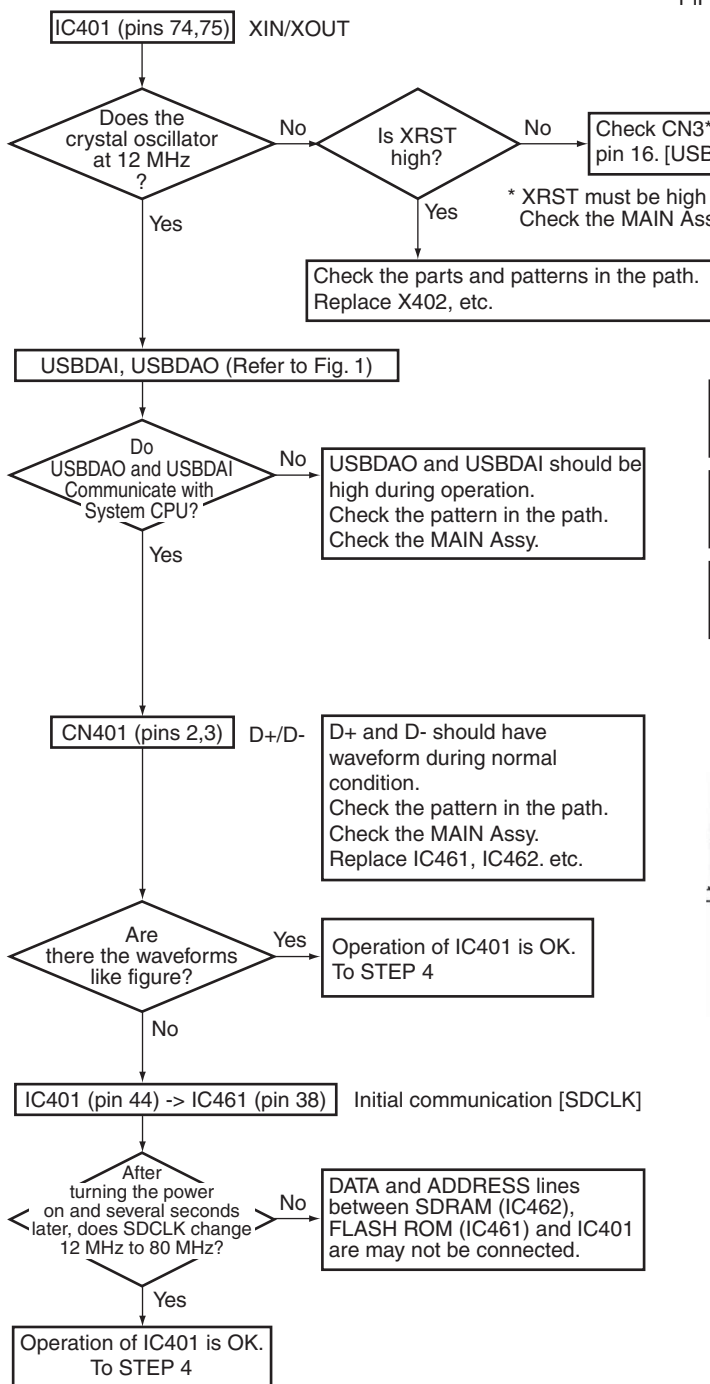

Fig. 1

	<b>IC401</b>		<b>CN3*, CN7**</b>
XRST	pin 77	R455 / R456	pin 16
	<b>IC401</b>	<b>IC331 (5 V -&gt; 3 V)</b>	<b>CN3*, CN7**</b>
USBDAI	pin 96	pin 8	pins 9, 10
	<b>IC401</b>	<b>IC351 (3 V -&gt; 5 V)</b>	<b>CN3*, CN7**</b>
USBDAO	pin 95	pin 9	pin 11

\* VSX-918V (AWX8977)  
\*\* VSX-818V (AWX9164)

Fig. D+

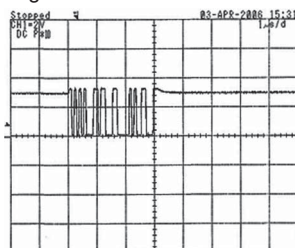
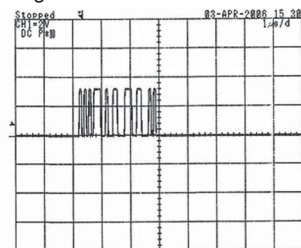

Fig. D-



X: 1 μS/div, Y: 2 V/div

X: 1 μS/div, Y: 2 V/div

### Step 4: Operation of iPod (Authentication process)

Note: Please confirm it with connecting the iPod.

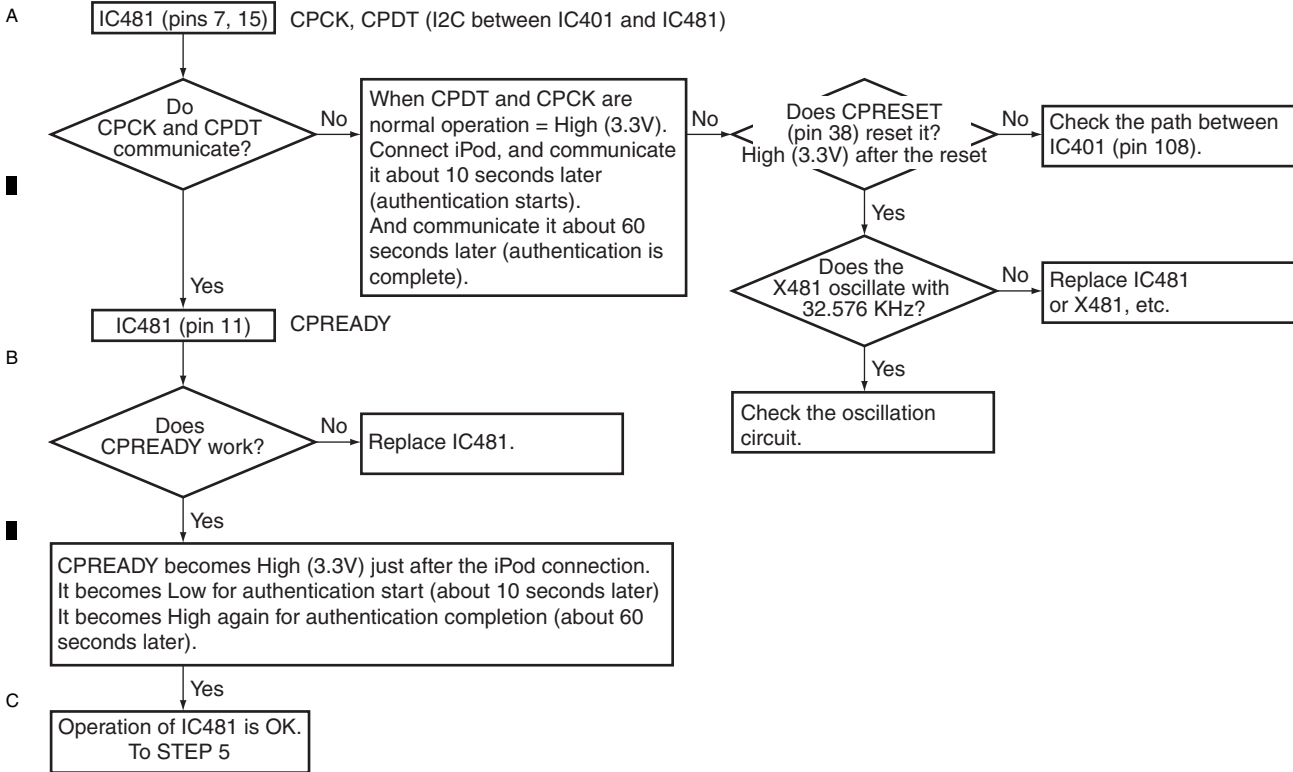

### Step 5: Audio Out check

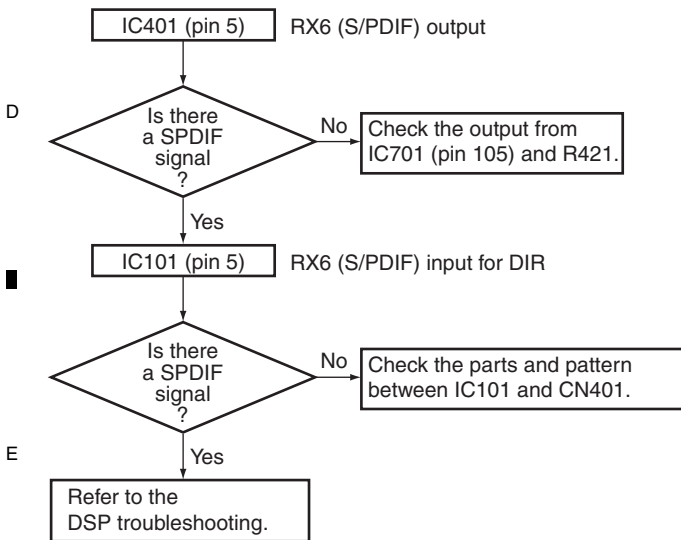

### [3] HDMI TROUBLESHOOTING

#### ■ HDMI Simple Diagnosis (VSX-918V)

##### 1. Causes for noncompletion of HDMI authentication between the source equipment and this unit (the HDMI indicator is unlit or flashes)

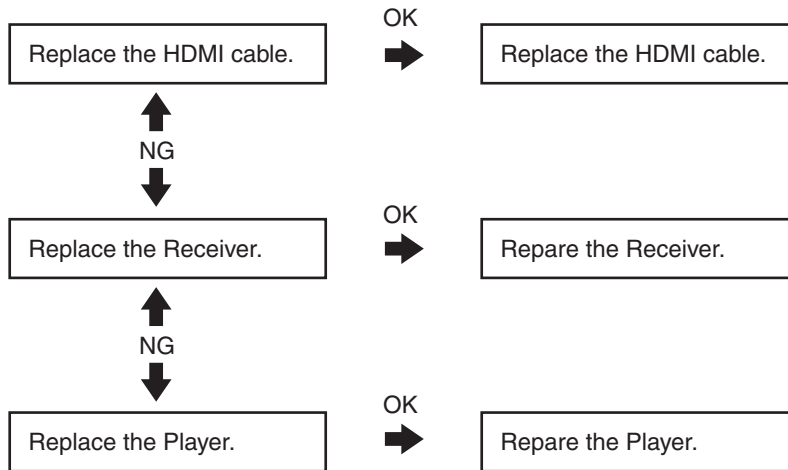

##### 2. Causes for noncompletion of HDMI authentication between the monitor and this unit (no display or sound from the monitor)

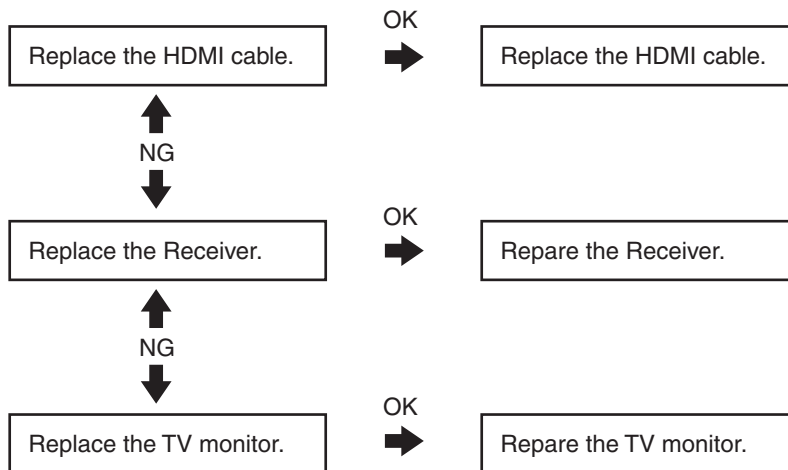

#### ■ HDMI Simple Diagnosis (VSX-818V)

##### Causes for no display or sound from the monitor

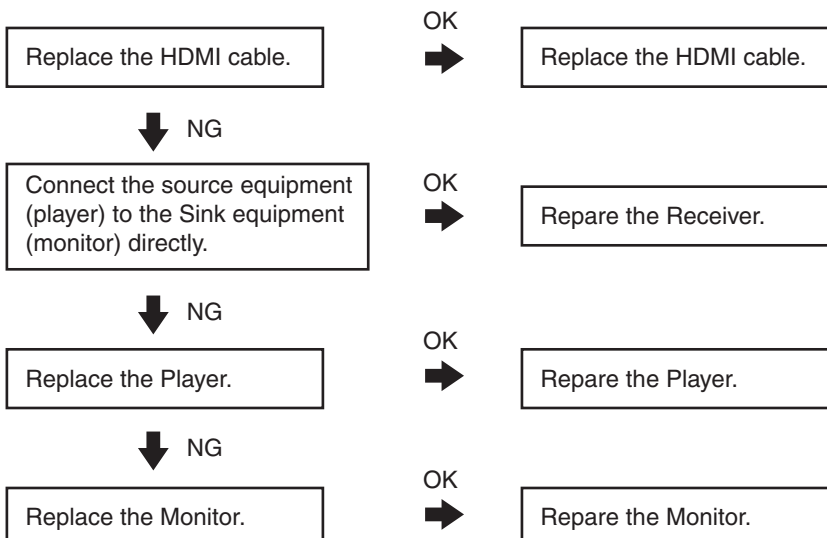

# HDMI Troubleshooting (VSX-818V)

This shows failure analysis of the HDMI Assy.

## Preparation

### Step 1-1: Screws on the rear panel

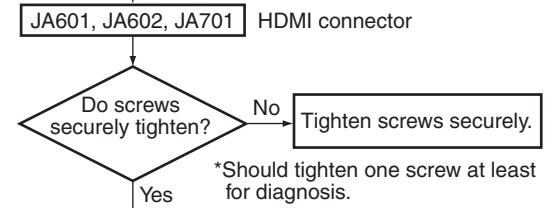
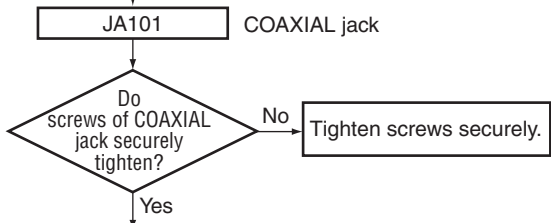

### Step 1-2: FFC

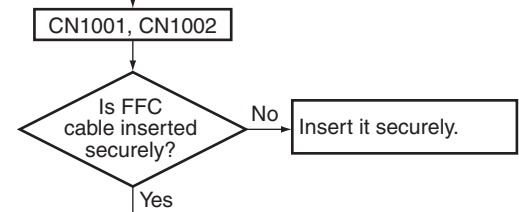

### Step 1-3: Connect the HDMI equipment

Source equipment:  
Connect a DVD player to HDMI 1 or HDMI 2.

Sink equipment:  
Connect a TV to HDMI OUT.

### Step 1-4: POWER ON

Turn on the power of the Receiver and equipments which was connected with HDMI.

### Step 1-5: Function switch (HDMI 1 or HDMI 2)

Switch the function that HDMI was assigned.  
Factory shipments setting:  
HDMI 1: DVD  
HDMI 2: TV

To Step 2

## Diagnosis

### Step 2-1: CE

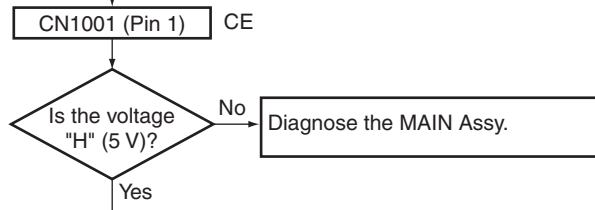

### Step 2-2: Power supply

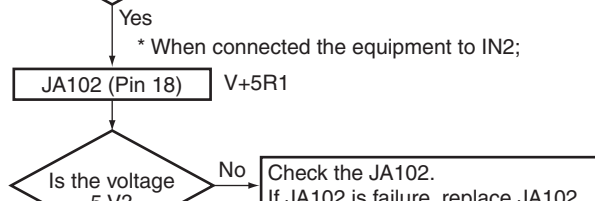
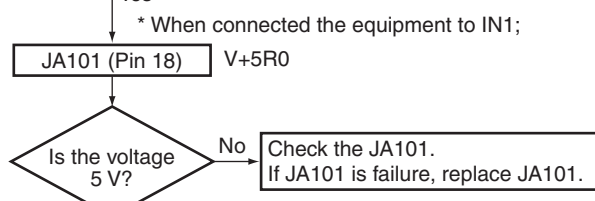
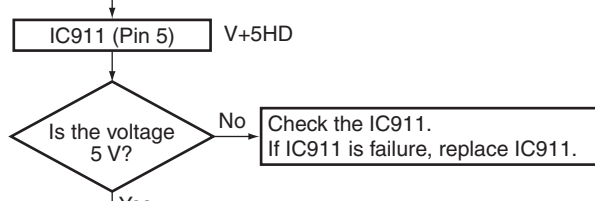
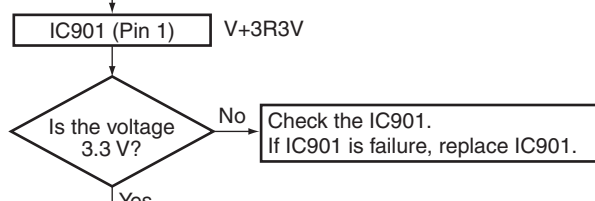
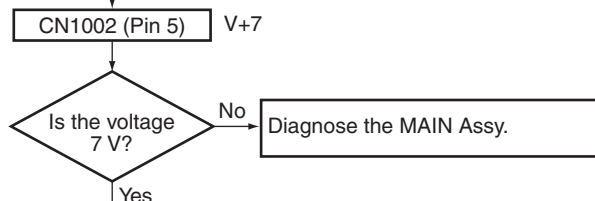
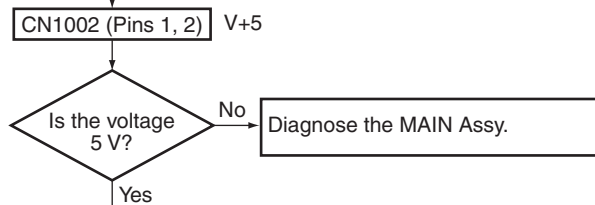

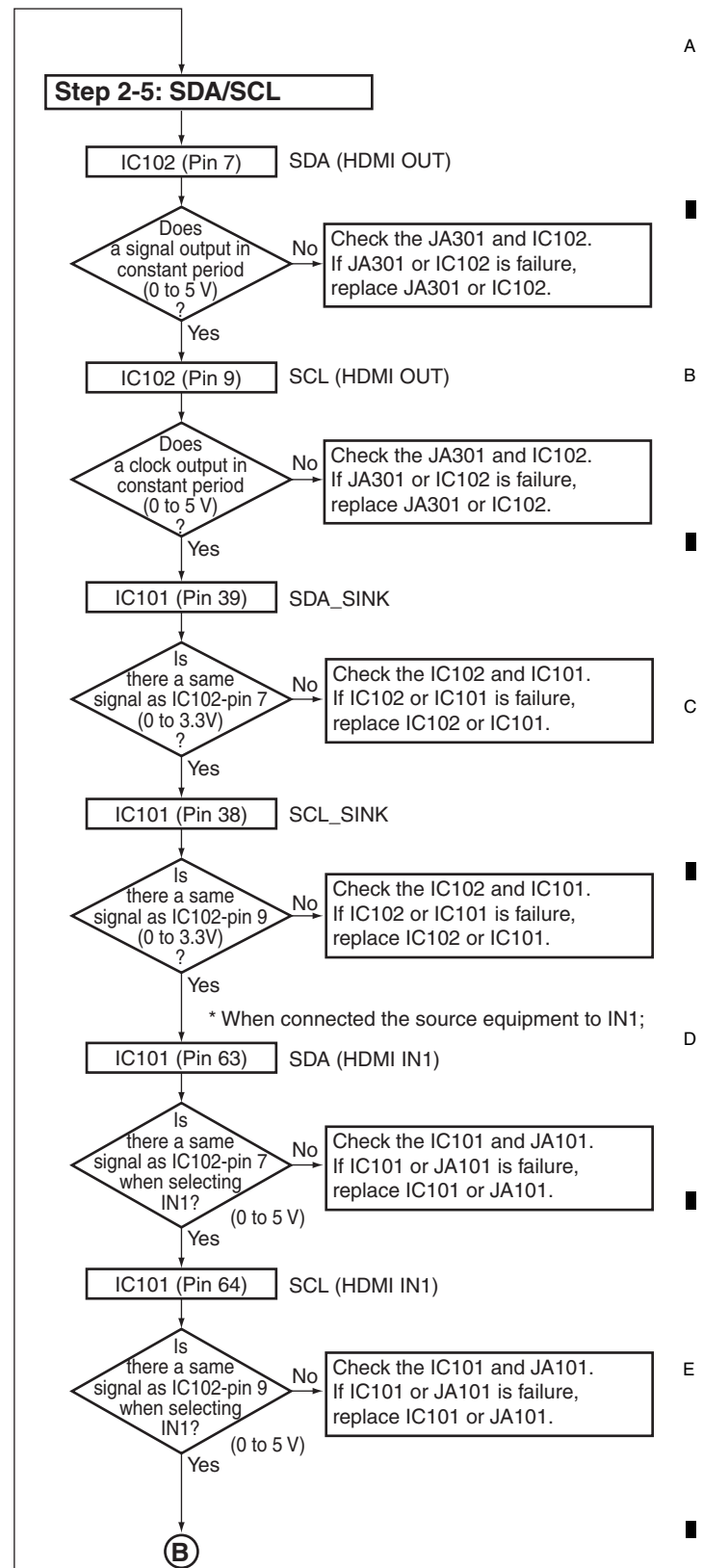
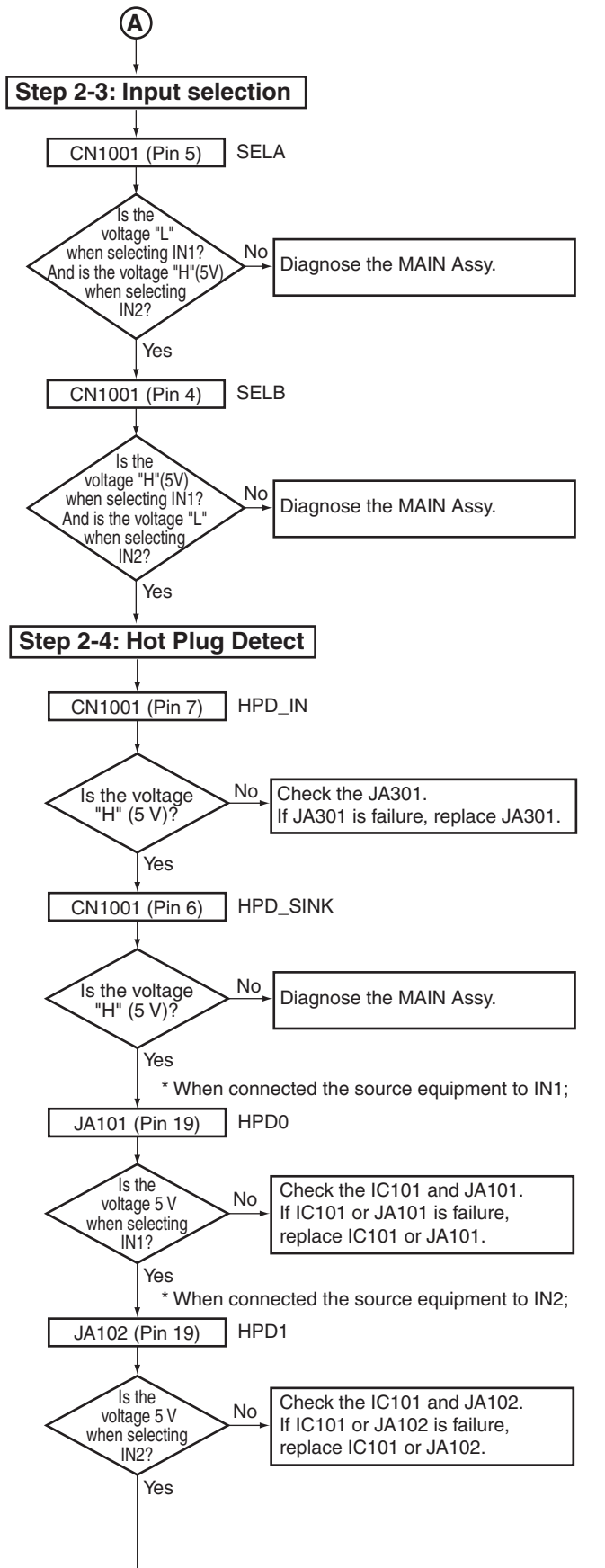

(B)

\* When connected the source equipment to IN2;

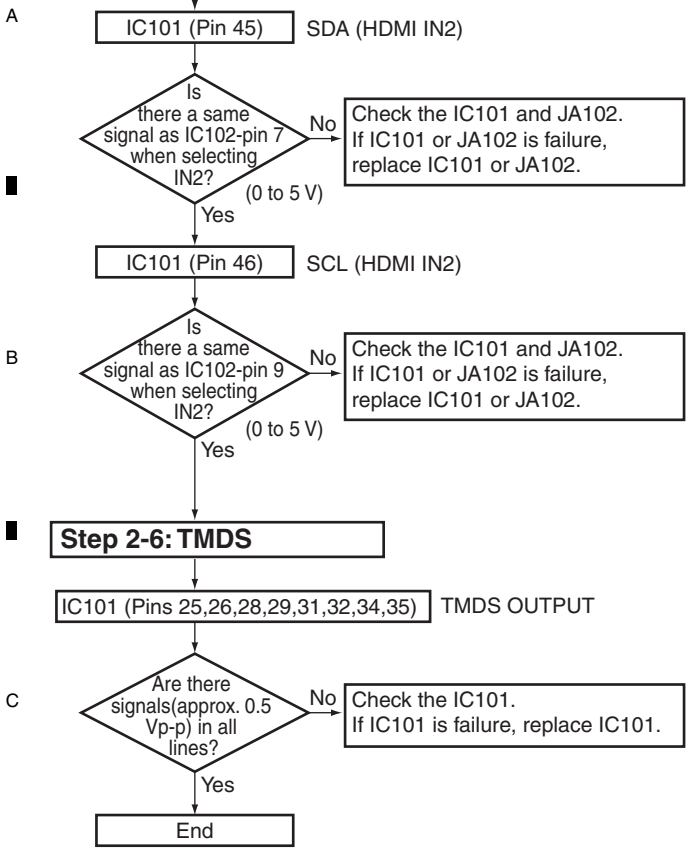

## 5.2 DETECTION CIRCUIT

### 1. DC Derection Circuit Diagram : Example of VSX-918V/KUXJ/CA

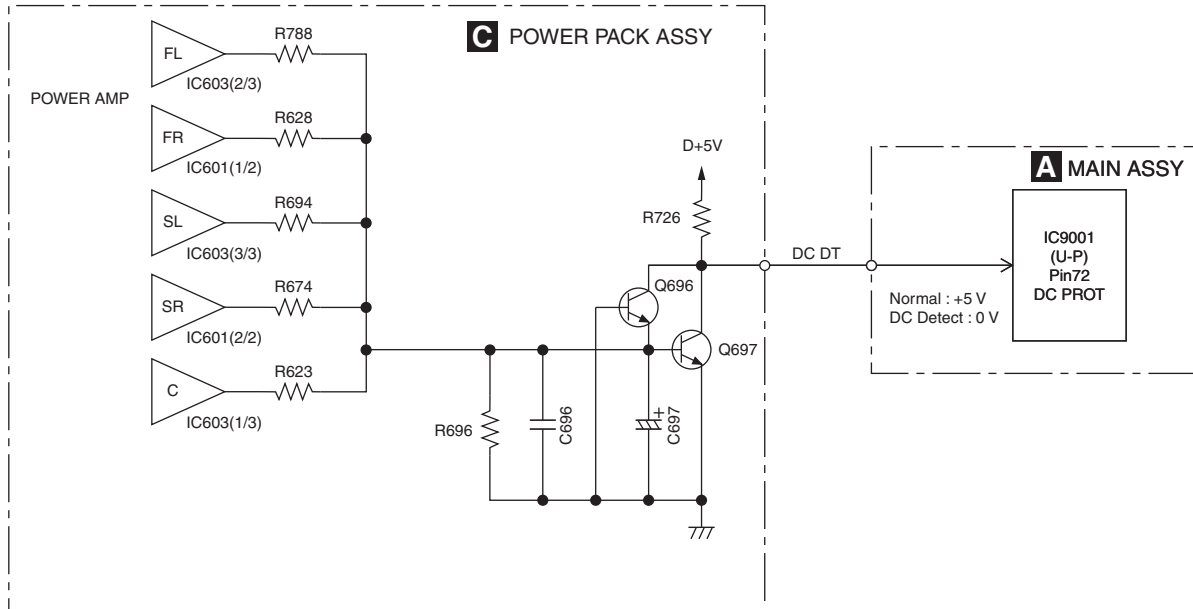

### 2. Overload Detection Circuit Diagram: Example of VSX-918V/KUXJ/CA FRONT Channel

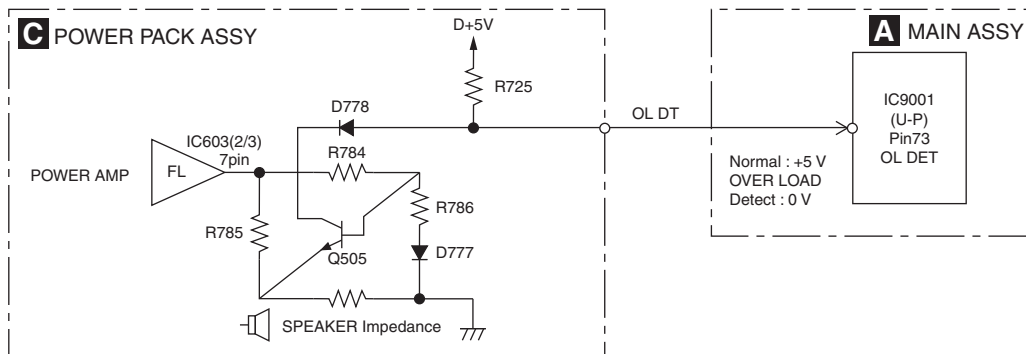

### 3. Fan Stop Protection Circuit Diagram

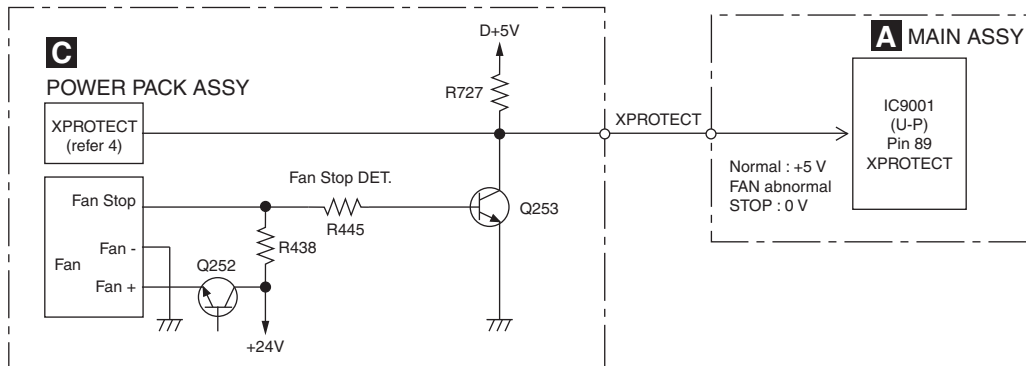

### 4. XPROTECT Detection Circuit Diagram

When below 6 kind of voltage supply become to be short circuit to GND, XPROTECT circuit work and U-P input port voltage change from +5 V to 0 V. The U-P detect this condition as ERROR.

- Voltage supply to POWER AMP IC (V neck+)
- Voltage supply to POWER AMP IC (V neck-)
- Voltage supply to +12 V REGULATOR IC
- Voltage supply to -12 V REGULATOR IC

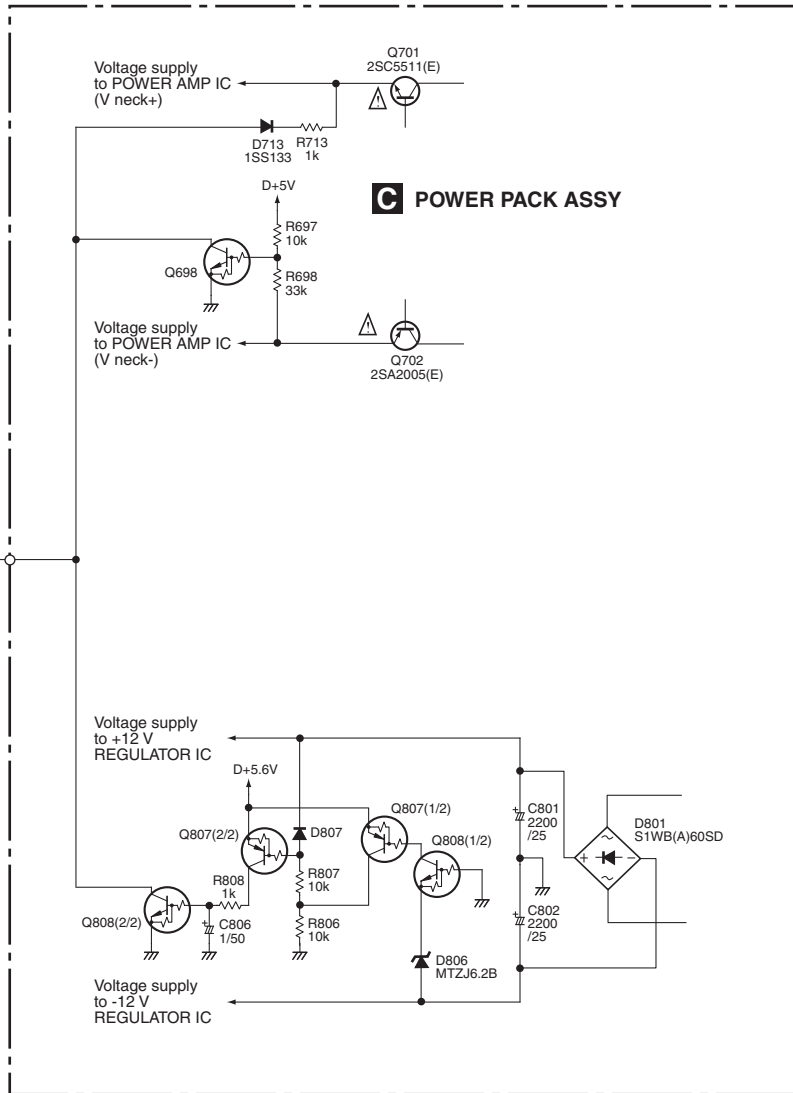
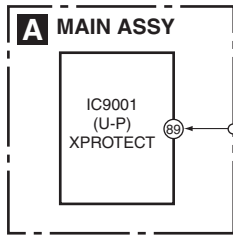

## 5.3 AMPLIFIER SYSTEM PROTECTION OPERATION SPECIFICATION

### 1. DC-abnormality detection

DC detection is only enabled 2 seconds after power-on.

If there is a fault in the power amplifier or a high-level signal lower than 5 Hz is input, the DC\_DET port becomes "L".

If the "L" is detected, the microprocessor will perform as following flow chart.

In the case of simultaneous detection with the overload protection circuit, DC-abnormality detection is performed preferentially to overload detection.

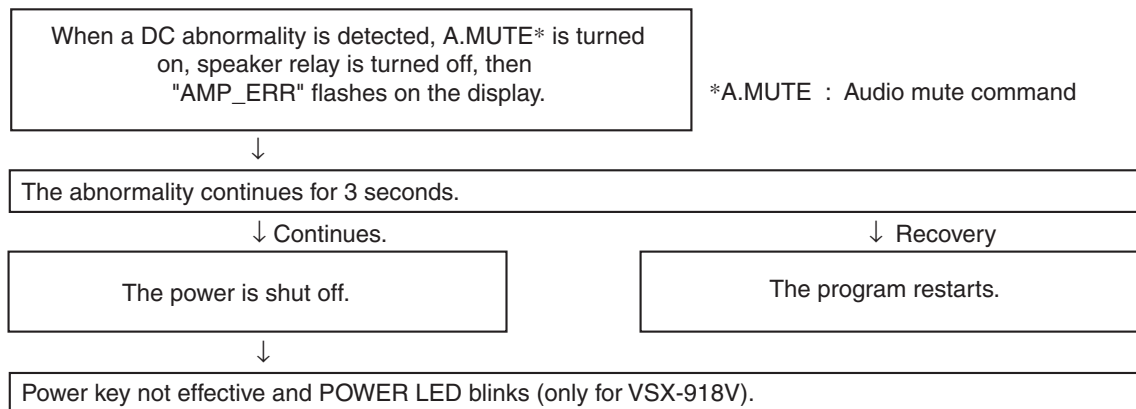

\*A.MUTE : Audio mute command

However, when the following keys are pushed so that the key input of a line and the service can be carried out, power can be on.

① TESTMODE ON (A55F+A55F)

② When power off, push TUNE+ key + AUTO SURR/DIRECT key continuously 2sec.

(②: When a DC abnormality is detected and the power is shut off.)

Any other key input from front panel or remote control will not be detected.

### 2. Overload detection

If the speaker terminals are short-circuited or low-load driving is detected, the OL\_DET port becomes "L".

If the "L" is detected, the microprocessor will perform as following flow chart.

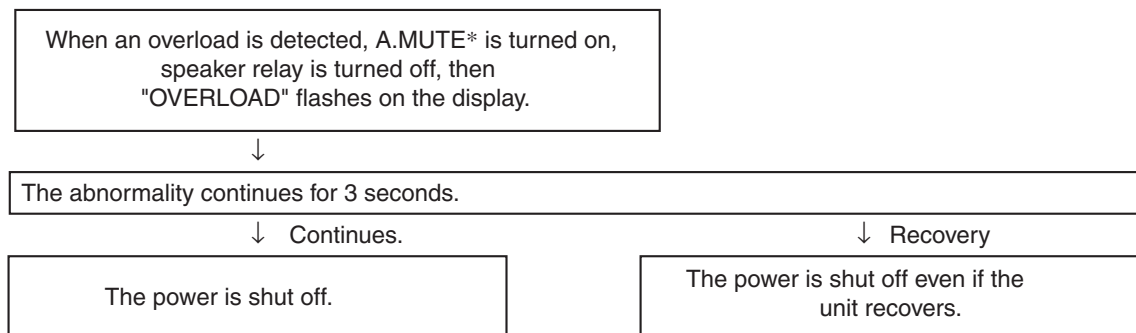

### 3. XPROTECT detection

XPROTECT is started to be monitored 200msec after power on.

XPROTECT port is checked every 20msec.

If Low level (ERROR) is recognized during consecutive 9 times, micon judge it as XPROTECT ERROR.

It processes more preferentially than DC abnormal detection and overload detection.

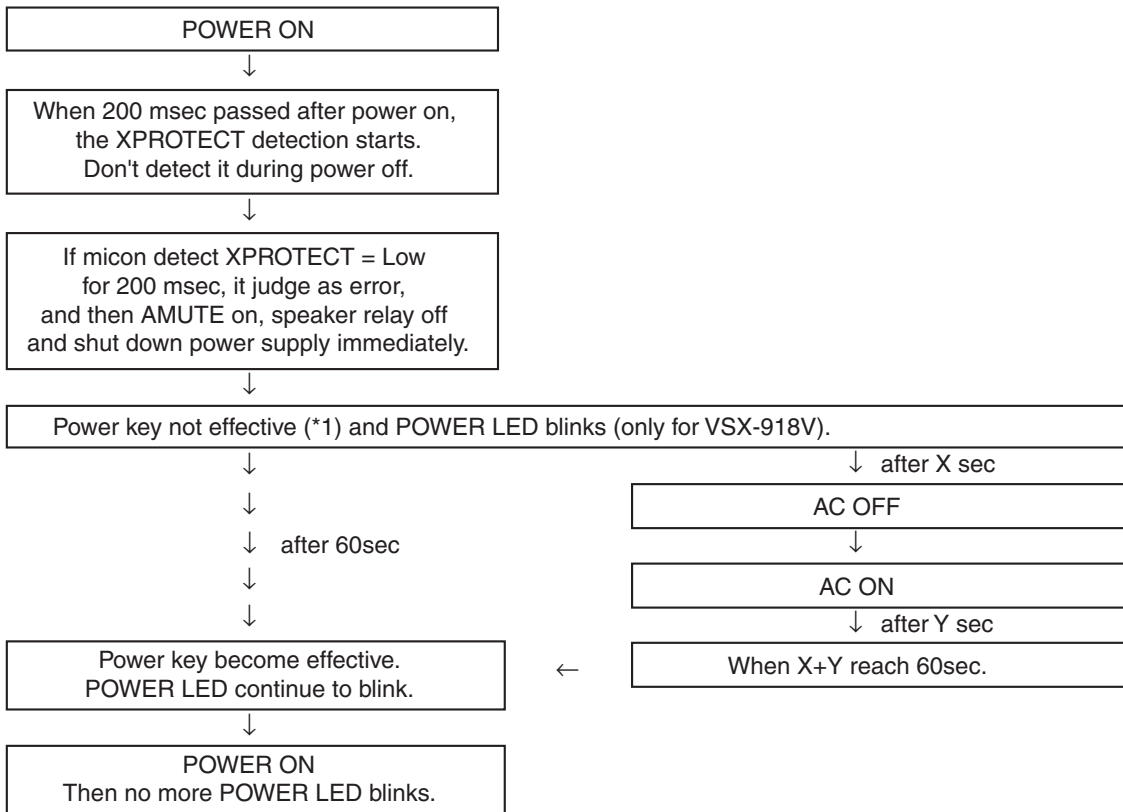

(\*1) However, when the following keys are pushed so that the key input of a line and the service can be carried out, power can be on.

① TESTMODE ON (A55F+A55F)

② When power off, push TUNE+ key + AUTO SURR/DIRECT key continuously 2sec.

(Effective, only when power-off is carried out by DC detection / XPROTECT detection)

Any other key input from front panel or remote control will not be detected.

### 4. Fan stop detection operation flow in the XPROTECT detection

If the fan is forcibly stopped or become out of order, the 'XPROTECT' port becomes "L". Then an abnormality of fan is detected.

- Detection routine and recovery is same as "3. XPROTECT detection".

There is no information to be shown in this chapter.

A  
B  
C  
D  
E  
F

# 7. DISASSEMBLY

**Note 1:** Even if the unit shown in the photos and illustrations in this manual may differ from your product, the procedures described here are common.

**Note 2:** For performing the diagnosis shown below, the following jigs for service are required:

- Extension jig cables : GGD1483, GGD1485

## Diagnosis of HDMI

**Caution:**

Heatsink section in work becomes hot, and be careful with it.

① Remove the bonnet by removing the six screws.

• For VSX-918V

- ① Remove the three screws.
- ② Remove the one screw.
- ③ Disconnect the two connectors.
- ④ Remove the HDMI&DSP&USB Assy.

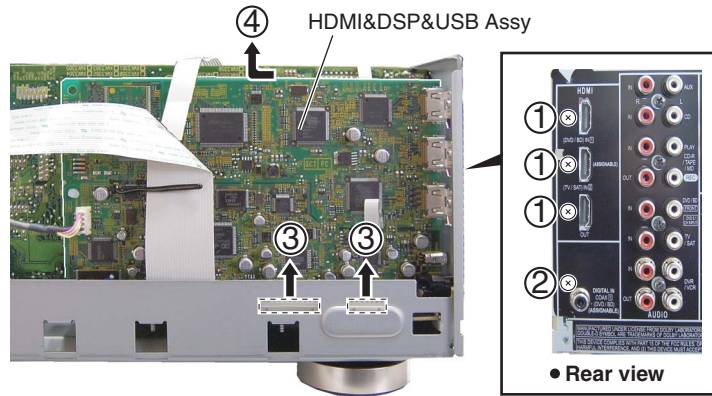

- ⑤ Connect the two extension jig cables.  
GGD1483  
(HDMI&DSP&USB CN1 <=> POWER PACK CN805)  
GGD1485  
(HDMI&DSP&USB CN2 <=> POWER PACK CN806)

- ⑥ Connect the ground line.  
(HDMI&DSP&USB COAX terminal <=> Rear panel,  
One of the three HDMI terminals <=> Rear panel)

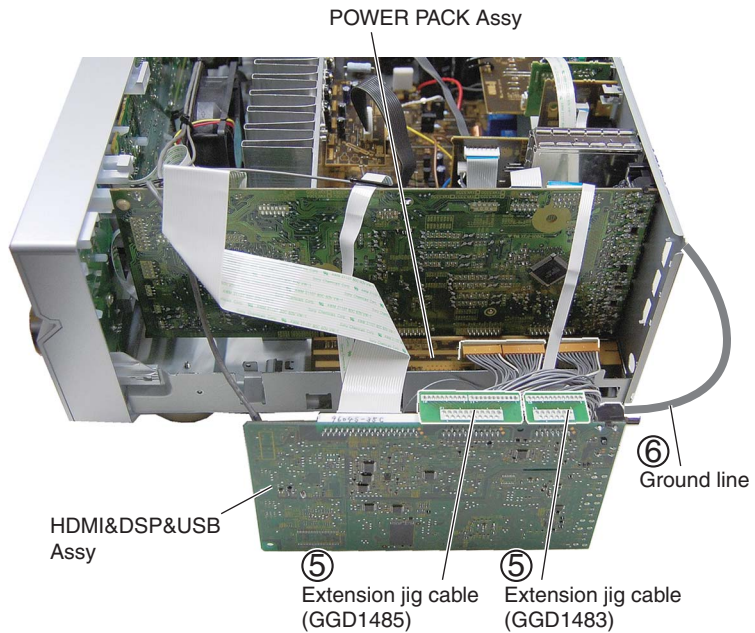

**Diagnosis**

● For VSX-818V

- ① Remove the three screws.
- ② Remove the one screw.
- ③ Release the PCB holder.
- ④ Remove the HDMI Assy.
- ⑤ Release the PCB holder.
- ⑥ Disconnect the two connectors.
- ⑦ Remove the DSP&USB Assy.

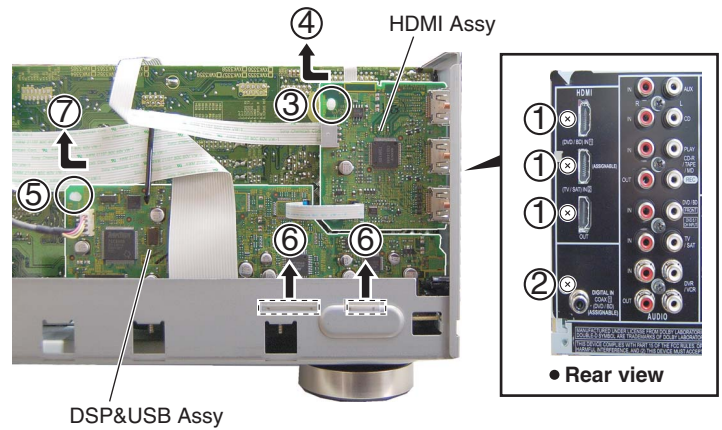

- ⑧ Connect the two extension jig cables.  
GGD1483  
(DSP&USB CN1 <=> POWER PACK CN805)  
GGD1485  
(DSP&USB CN2 <=> POWER PACK CN806)
- ⑨ Connect the ground line.  
(DSP&USB COAX terminal <=> Rear panel)  
(HDMI One of the three HDMI terminals <=> Rear panel)

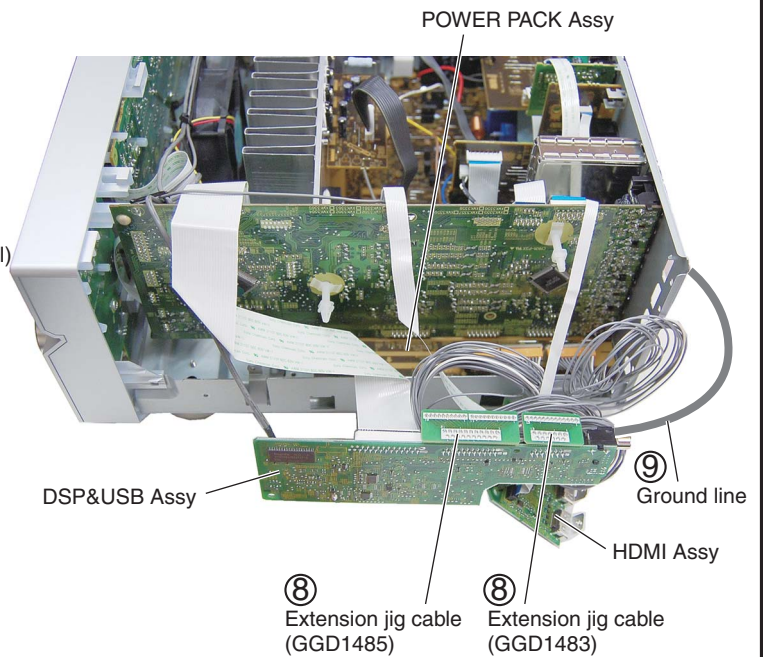

**Diagnosis**

# Diagnosis of the Unit

## Caution:

Heatsink section in work becomes hot, and be careful with it.

① Remove the bonnet by removing the six screws.

① Remove the two screws.

② Remove the one screw.

③ Remove the two screws.

④ Remove the one screw.

⑤ Remove the push rivet.

⑥ Remove the BIND Assy by removing the one screw.

⑦ Remove the one screw.

⑧ Release the binders, as required.

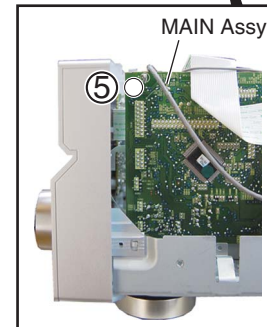
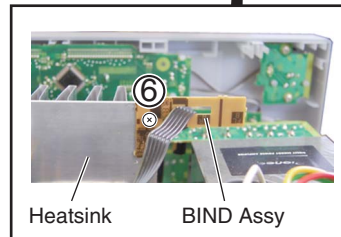
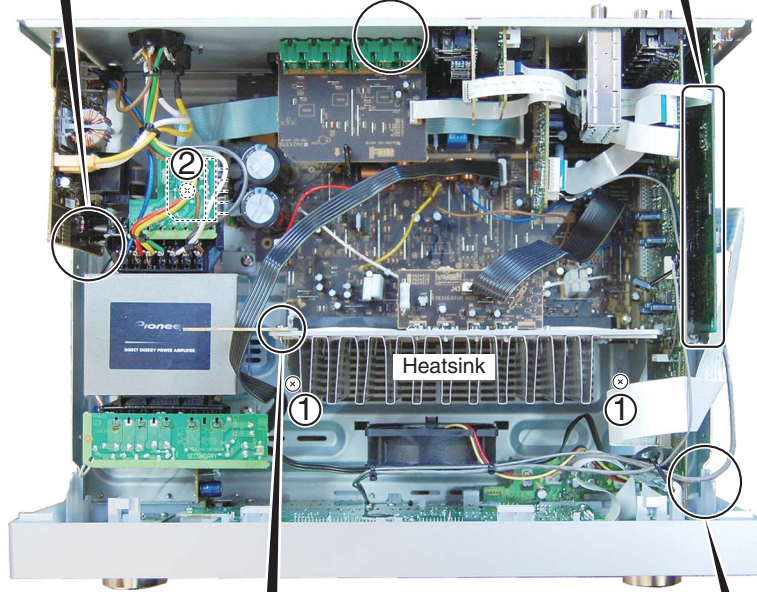
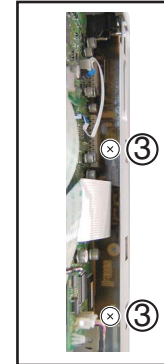
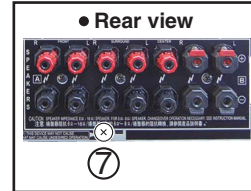
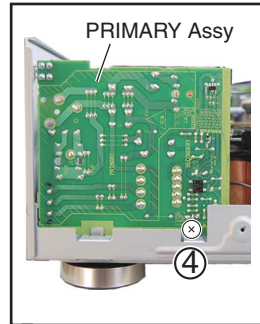

⑨ Arrange the unit as shown in the photo below.

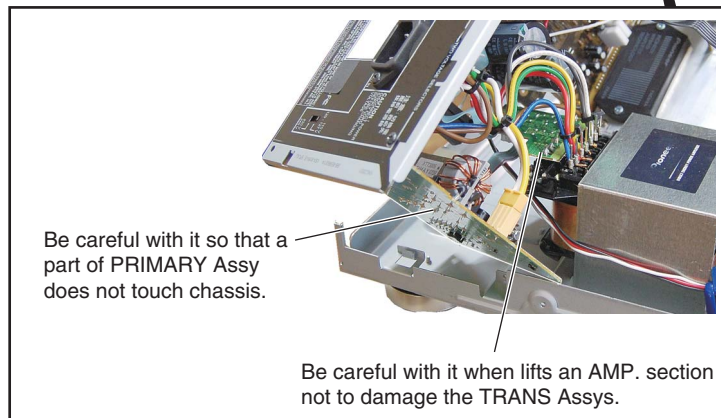
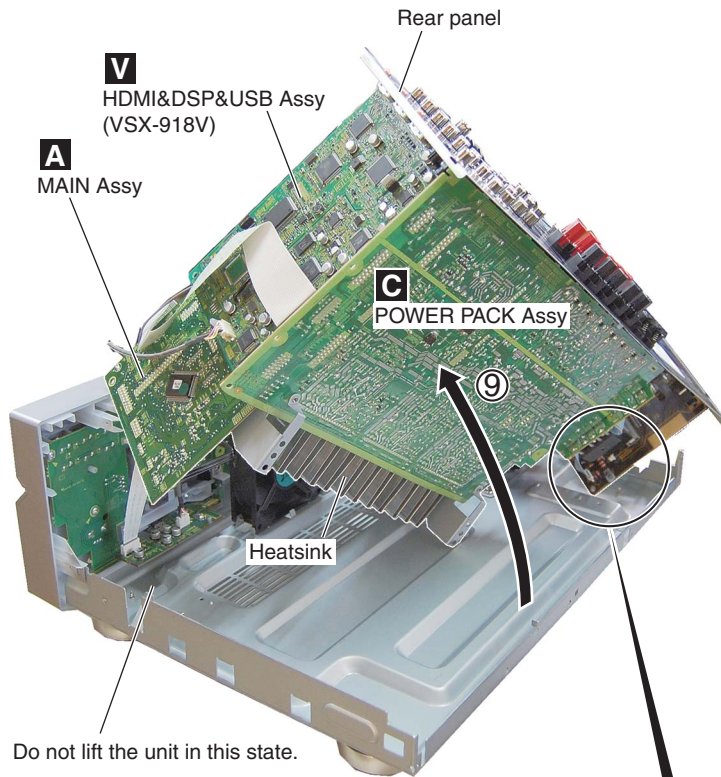
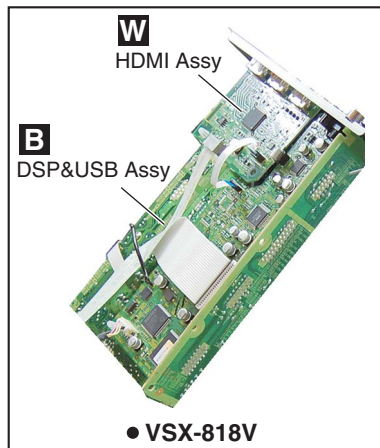

↓  
**Diagnosis**

**Caution:**

During diagnosis, be sure NOT to remove the four screws marked ① in the above photo. There is the case that a product does not work normally when removes these screws.

① One of the three terminals

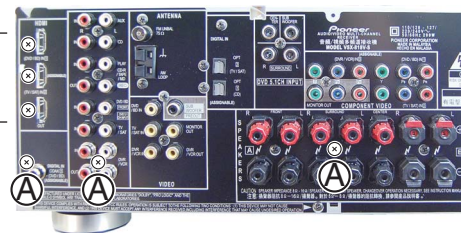

# Disassembly

## Front Panel Section

### Caution:

Heatsink section in work becomes hot, and be careful with it.

1 Remove the bonnet by removing the six screws.

1 Remove the five screws.

2 Remove the two screws.

3 Unhook the two hooks.

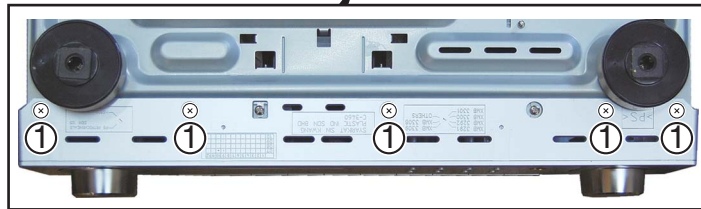
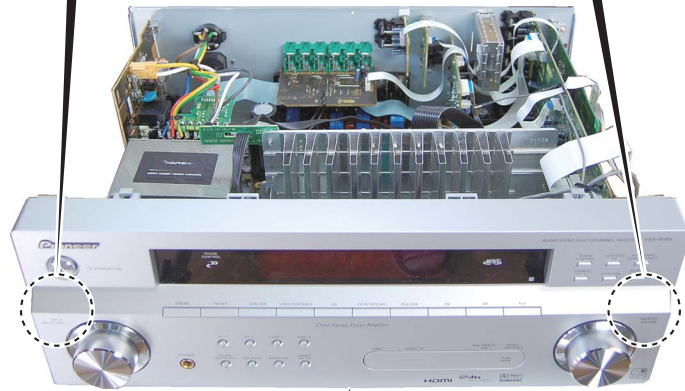
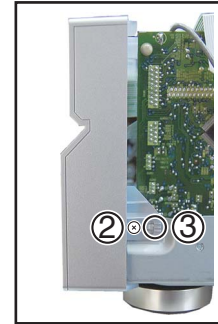
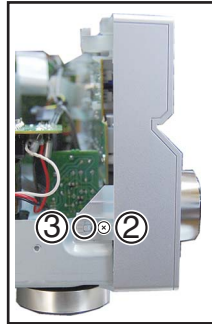

4 Remove the front panel section.

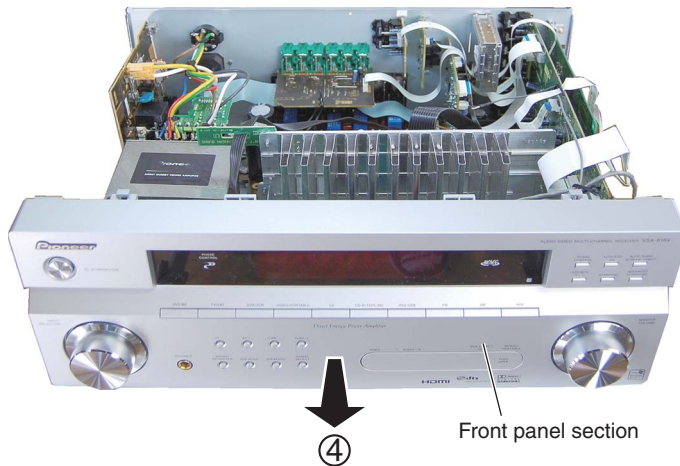

## 8. EACH SETTING AND ADJUSTMENT

### 8.1 HOW TO UPDATE FIRMWARE

#### ■ USB Firmware Update

##### [Purpose]

Refer to this section when updating the USB firmware is required by the service information, etc.  
It is able to update the USB firmware by using USB flash memory.

##### [Necessary Tools]

- USB Flash Memory which is saved the firmware file ("player.rom" file).

##### Note:

In rare cases, it is not able to update the firmware depending on the type of USB flash memory.  
In such a case, try to use other model of USB flash memory.

##### [Procedures]

1. Tuner VOL to "-- dB".
2. Turn off the set.
3. Press "Standby/On" and "PHASE CONTROL" keys simultaneously for about 5 secs.  
"USB" or "IPOD" will be displayed on FL, soon after that "WAITING" display will appear.  
Then after about 20 secs, the current USB firmware version will be shown.
4. Insert the USB memory device containing latest USB firmware to the USB slot on front panel.  
Soon "UPDT 000" will appear on FL, followed by the progress counting down.
5. When it is finished, "COMPLETE" will appear on FL.
6. Turn off the set, then turn it on again.
7. You may check the version by turning the set to off, then pressing "Standby/On" and "PHASE CONTROL" keys simultaneously for about 5 secs.

##### Note:

- Do NOT reconnect the USB flash memory which is saved the "player.rom" file.
- Do NOT change the function setting or turn off the power during step 5 through 7.  
If you do, the updating is failed and it is required to replace the USB flash ROM on the USB module.



**(1) PACKING SECTION PARTS LIST**

<b>Mark No.</b>	<b>Description</b>	<b>Part No.</b>	<b>Mark No.</b>	<b>Description</b>	<b>Part No.</b>
1	FM Wire Antenna	ADH7030	NSP 16	Warranty Card	ARY7111
2	AM Loop Antenna	ATB7013	17	Operating Instructions (Italian)	XRC3320
3	Microphone (for Auto MCACC setup)	APM7008	18	Operating Instructions (Dutch)	XRC3321
4	Operating Instructions (English)	XRB3091	19	Operating Instructions (Spanish)	XRC3322
5	Label (WEEE)	ARW7322	20	Operating Instructions (French)	XRC3323
6	Remote Control	See Contrast table (2)	21	Operating Instructions (German)	XRC3324
7	Battery Cover	AZN7933	22	Operating Instructions (Russian)	XRC3331
NSP 8	Dry Cell Battery (AA, R6)	XEX3002			
NSP 9	Polyethylene Bag (0.03 x 230 x 340)	Z21-038			
10	Packing Sheet	AHG7069			
11	Left Pad V5	XHA3174			
12	Right Pad V5	XHA3175			
13	Packing Case	See Contrast table (2)			
14	Sub Pad	XHA3179			
NSP 15	DS Tape	XEH3001			

**(2) CONTRAST TABLE**

VSX-918V-K/MYSXJ5, VSX-918V-S/MYSXJ5, VSX-818V-K/MYSXJ5 and VSX-818V-S/MYSXJ5 are constructed the same except for the following:

Mark	No.	Symbol and Description	VSX-918V-K/ MYSXJ5	VSX-918V-S/ MYSXJ5	VSX-818V-K/ MYSXJ5	VSX-818V-S/ MYSXJ5
	6	Remote Control	XXD3166	XXD3167	XXD3166	XXD3167
	13	Packing Case	XHD3764	XHD3765	XHD3773	XHD3774

# 9.2 EXTERIOR SECTION

1 2 3 4

A  
B  
C  
D  
E  
F

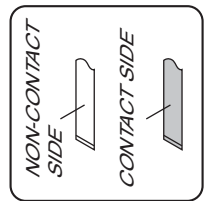

Refer to "9.3 REAR PANEL SECTION".

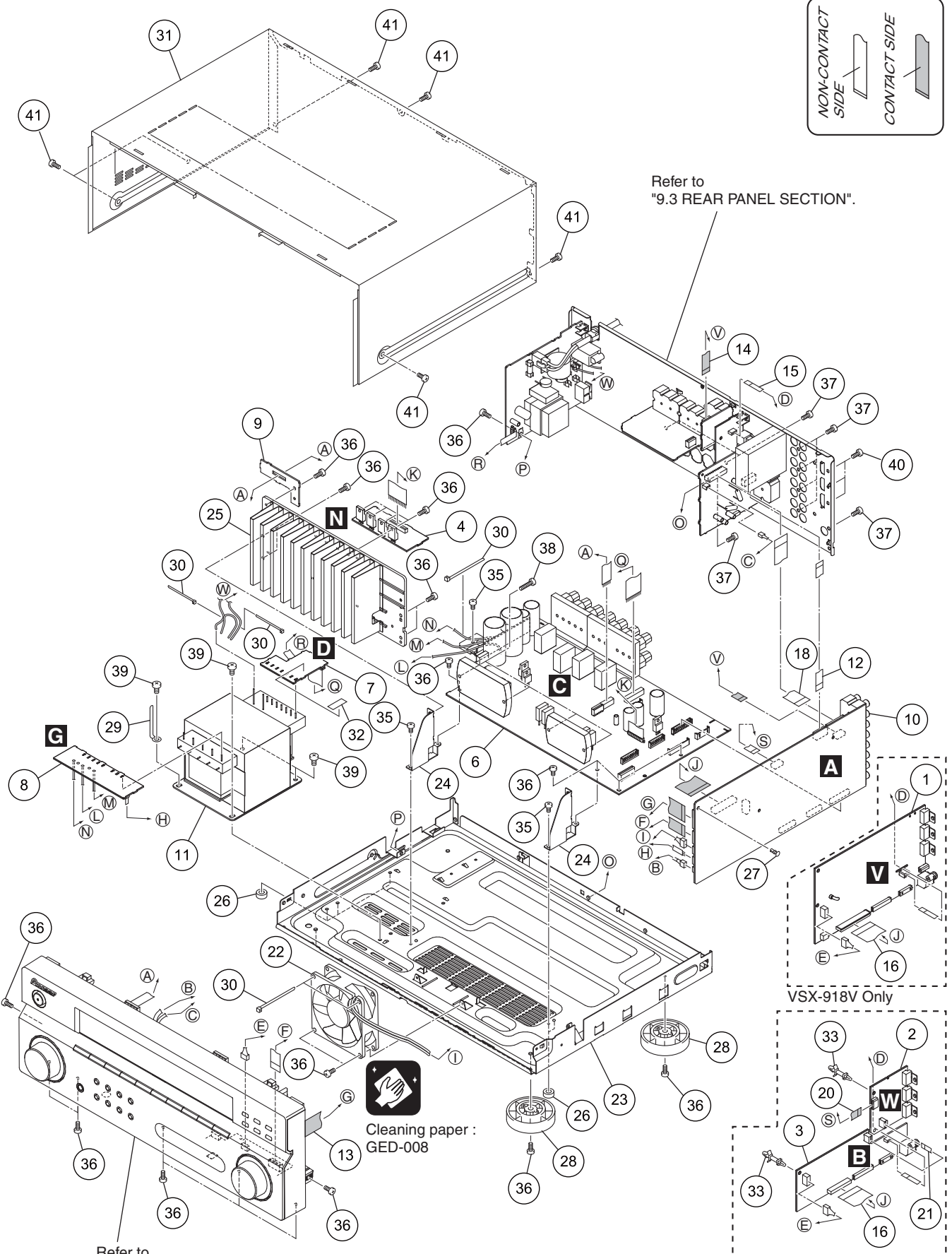

Cleaning paper : GED-008

Refer to "9.4 FRONT PANEL SECTION".

VSX-918V Only

VSX-818V Only

1 2 3 4

**(1) EXTERIOR SECTION PARTS LIST**

<b>Mark No.</b>	<b>Description</b>	<b>Part No.</b>	<b>Mark No.</b>	<b>Description</b>	<b>Part No.</b>
1	HDMI_DSP_USB Assy	See Contrast table (2)	NSP 26	Spacer	AEB7092
2	HDMI Assy	See Contrast table (2)	27	Push Rivet	AEC7205
3	DSP_USB Assy	See Contrast table (2)	28	Insulator	PNW2766
4	REGULATOR Assy	XWZ4317	29	Cord Clamper	RNH1005
5	•••••		NSP 30	Binder (BK-1)	ZCA-BK1
6	POWER PACK Assy	XWZ4326	31	Bonnet	See Contrast table (2)
7	TRANS 2 Assy	XWZ4335	32	ICP Label	XAX3121
8	TRANS 3 Assy	XWZ4337	NSP 33	PCB Holder	See Contrast table (2)
9	BIND Assy	XWZ4344	34	•••••	
10	MAIN Assy	See Contrast table (2)	35	Screw	BBZ30P060FCC
⚠ 11	Power Transformer (T1501)	XTS3113	36	Screw	BBZ30P080FNI
12	11P Flexible Cable (J1911)	XDD3189	37	Screw	BBZ30P080FTB
13	17P Flexible Cable (J1905)	XDD3200	38	Screw	BBZ30P140FTC
14	7P Flexible Cable (J1919)	XDD3235	39	Screw	BBZ40P080FNI
15	5P Flexible Cable (J1912)	XDD3248	40	Screw	PMZ30P060FCC
16	35P Flexible Cable (J1917)	See Contrast table (2)	41	Screw	See Contrast table (2)
17	•••••				
18	19P Flexible Cable (J1908)	See Contrast table (2)			
19	•••••				
20	7P Flexible Cable	See Contrast table (2)			
21	5P Flexible Cable	See Contrast table (2)			
⚠ 22	DC Fan Motor	XXM3012			
NSP 23	Chassis 918	XNA3060			
24	H/S Angle V3	XNG3145			
NSP 25	H/Sink V5	XNH3048			

**(2) CONTRAST TABLE**

VSX-918V-K/MYSXJ5, VSX-918V-S/MYSXJ5, VSX-818V-K/MYSXJ5 and VSX-818V-S/MYSXJ5 are constructed the same except for the following:

Mark	No.	Symbol and Description	VSX-918V-K/ MYSXJ5	VSX-918V-S/ MYSXJ5	VSX-818V-K/ MYSXJ5	VSX-818V-S/ MYSXJ5
	1	HDMI_DSP_USB Assy	AWX8977	AWX8977	Not used	Not used
	2	HDMI Assy	Not used	Not used	AWX8966	AWX8966
	3	DSP_USB Assy	Not used	Not used	AWX9164	AWX9164
	10	MAIN Assy	XWK3363	XWK3363	XWK3359	XWK3359
	16	35P Flexible Cable (J1917)	XDD3249	XDD3249	Not used	Not used
	16	27P Flexible Cable (J1931)	Not used	Not used	XDD3271	XDD3271
	18	19P Flexible Cable (J1908)	XDD3253	XDD3253	Not used	Not used
	18	13P Flexible Cable (J1907)	Not used	Not used	XDD3259	XDD3259
	20	7P Flexible Cable (J1909)	Not used	Not used	XDD3255	XDD3255
	21	5P Flexible Cable (J1910)	Not used	Not used	XDD3256	XDD3256
NSP	31	Bonnet	XZN3196	XZN3197	XZN3196	XZN3197
	33	PCB Holder	Not used	Not used	PNW2174	PNW2174
	41	Screw	BBZ30P080FTB	BBZ30P080FNI	BBZ30P080FTB	BBZ30P080FNI

# 9.3 REAR PANEL SECTION

A

B

C

D

E

F

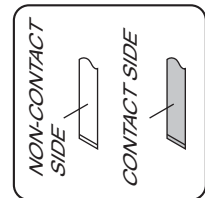
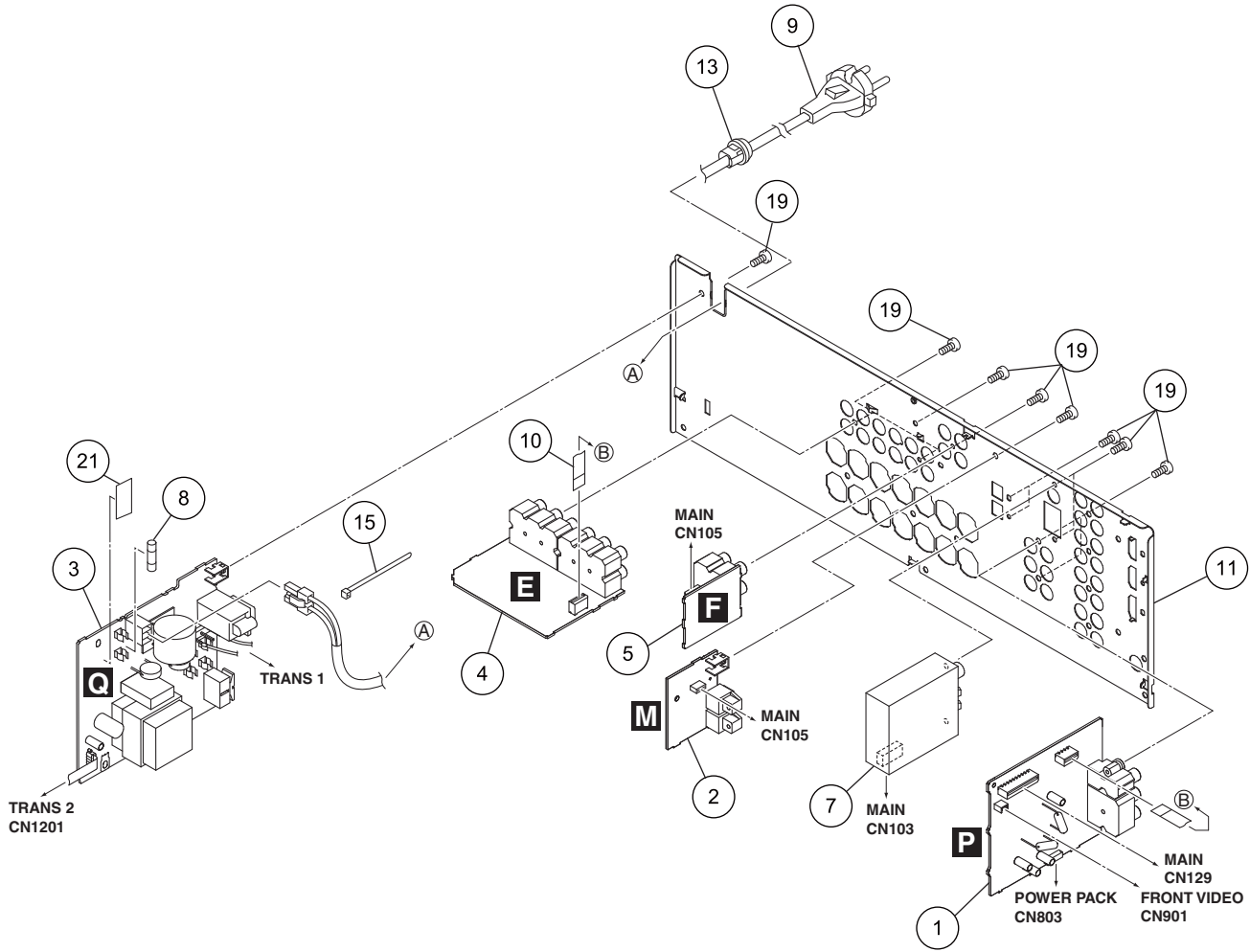

**(1) REAR PANEL SECTION PARTS LIST**

<u>Mark No.</u>	<u>Description</u>	<u>Part No.</u>	<u>Mark No.</u>	<u>Description</u>	<u>Part No.</u>
1	VIDEO Assy	See Contrast table (2)	16	•••••	
2	DIGITAL INPUT Assy	XWZ4299	17	•••••	
3	PRIMARY Assy	XWZ4302	18	Screw	BBZ30P080FNI
4	COMPONENT VIDEO Assy	XWZ4339	19	Screw	BBZ30P080FTB
5	5.1CH INPUT Assy	XWZ4341	20	Screw	PMZ30P060FCC
6	•••••		NSP 21	Fuse Card	AAX7493
7	FM/AM TUNER Unit	AXX7170			
⚠	8 Fuse (FU1: T3.15 A)	REK1027			
⚠	9 AC Power Cord	VDG1080			
10	7P Flexible Cable (J1913)	XDD3254			
11	R Panel	See Contrast table (2)			
12	•••••				
13	Cord Stopper	CM-22B			
14	•••••				
NSP 15	Binder (BK-1)	ZCA-BK1			

**(2) CONTRAST TABLE**

VSX-918V-K/MYSXJ5, VSX-918V-S/MYSXJ5, VSX-818V-K/MYSXJ5 and VSX-818V-S/MYSXJ5 are constructed the same except for the following:

Mark	No.	Symbol and Description	VSX-918V-K/ MYSXJ5	VSX-918V-S/ MYSXJ5	VSX-818V-K/ MYSXJ5	VSX-818V-S/ MYSXJ5
	1	VIDEO Assy	XWZ4294	XWZ4294	XWZ4292	XWZ4292
	11	R Panel	XNC3539	XNC3540	XNC3548	XNC3549

# 9.4 FRONT PANEL SECTION

A

B

C

D

E

F

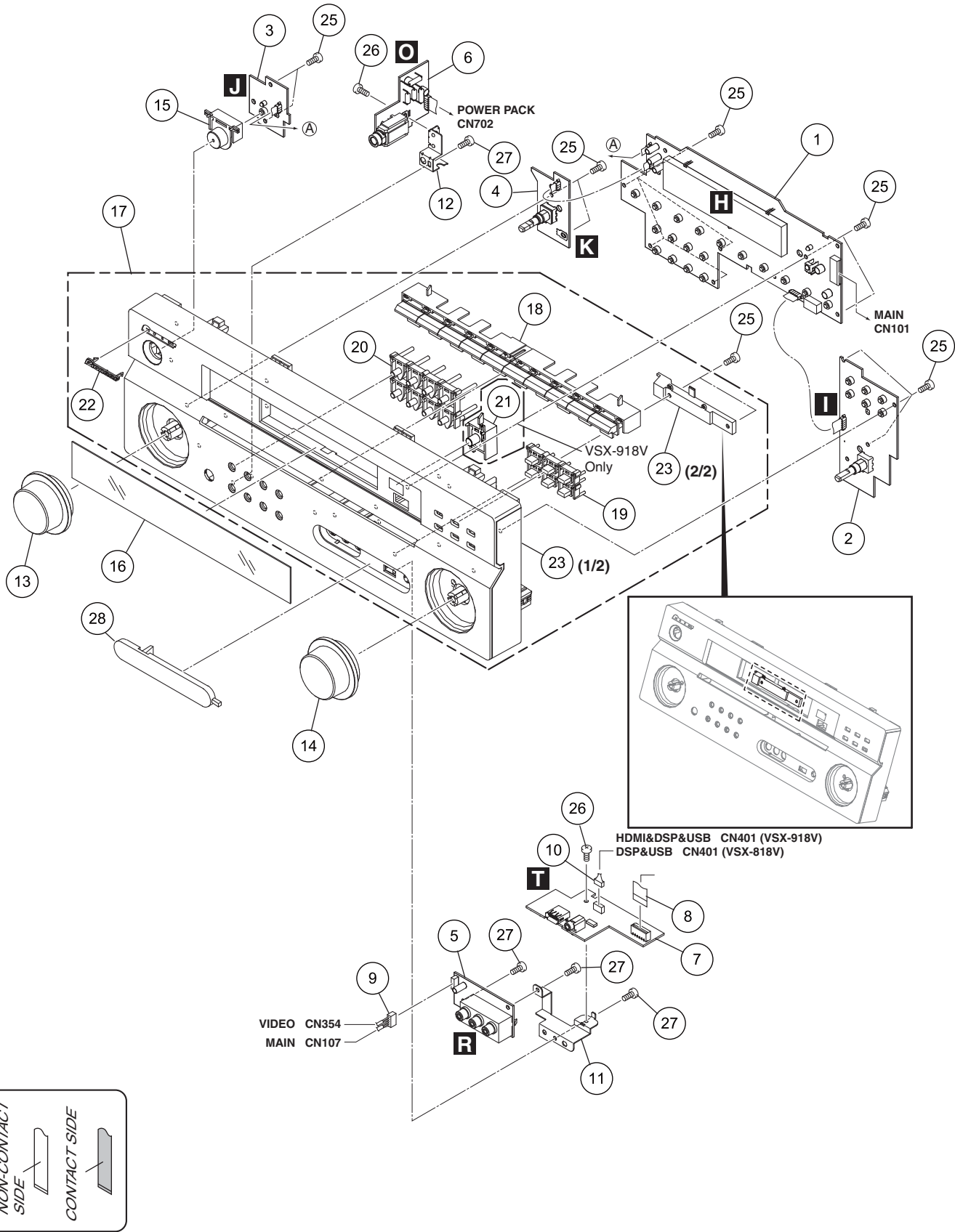

**(1) FRONT PANEL SECTION PARTS LIST**

<b>Mark No.</b>	<b>Description</b>	<b>Part No.</b>	<b>Mark No.</b>	<b>Description</b>	<b>Part No.</b>
1	FRONT DISPLAY Assy	See Contrast table (2)	16	D Panel	See Contrast table (2)
2	ROTARY ENCODER Assy	XWZ4286	NSP 17	F Panel Assy	See Contrast table (2)
3	POWER KEY Assy	See Contrast table (2)	18	FUNC BTN	See Contrast table (2)
4	JOG Assy	XWZ4289	19	SUB BTN	See Contrast table (2)
5	FRONT VIDEO Assy	XWZ4300	20	TUNER BTN	See Contrast table (2)
6	HEADPHONE Assy	XWZ4321	21	C Lens V3	See Contrast table (2)
7	FRONT IN Assy	XWK3366	22	Pioneer Name Plate	See Contrast table (2)
8	9P Flexible Cable (J1906)	XDD3247	23	FRT Panel	See Contrast table (2)
9	5P Shield Cable (J1904)	XDX3054	24	•••••	
10	4P Shield Cable (J1902)	XDX3063	25	Screw	BBZ30P080FTC
11	Earth Plate FR V3	XNG3144	26	Screw	BBZ30P080FNI
NSP 12	HP GND Plate	XNG3178	27	Screw	BPZ30P080FTC
13	VOL Knob V4	See Contrast table (2)	28	Inp. Cover	See Contrast table (2)
14	VOL Knob V5	See Contrast table (2)			
15	STANDBY BTN Assy	See Contrast table (2)			

**(2) CONTRAST TABLE**

VSX-918V-K/MYSXJ5, VSX-918V-S/MYSXJ5, VSX-818V-K/MYSXJ5 and VSX-818V-S/MYSXJ5 are constructed the same except for the following:

Mark	No.	Symbol and Description	VSX-918V-K/ MYSXJ5	VSX-918V-S/ MYSXJ5	VSX-818V-K/ MYSXJ5	VSX-818V-S/ MYSXJ5
NSP	1	FRONT DISPLAY Assy	XWZ4285	XWZ4285	XWZ4284	XWZ4284
	3	POWER KEY Assy	XWZ4288	XWZ4288	XWZ4287	XWZ4287
	13	VOL Knob V4	XAB3053	XAB3056	XAB3053	XAB3056
	14	VOL Knob V5	XAB3058	XAB3059	XAB3058	XAB3059
	15	STANDBY BTN Assy	XAD3216	XAD3217	Not used	Not used
	15	STANDBY BTN	Not used	Not used	XAD3202	XAD3208
	16	D Panel	XAK3593	XAK3593	XAK3594	XAK3594
	17	F Panel Assy	XXG3344	XXG3345	XXG3353	XXG3354
	18	FUNC BTN	XAD3257	XAD3258	XAD3257	XAD3258
	19	SUB BTN	XAD3259	XAD3260	XAD3259	XAD3260
	20	TUNER BTN	XAD3261	XAD3262	XAD3261	XAD3262
	21	C Lens V3	XAK3534	XAK3534	Not used	Not used
	22	Pioneer Name Plate	XAM3006	VAM1129	XAM3006	VAM1129
	23	FRT Panel	XMB3293	XMB3294	XMB3302	XMB3303
	28	Inp. Cover	XAK3596	XAK3597	XAK3596	XAK3598

# 10. SCHEMATIC DIAGRAM

## 10.1 MAIN ASSY (1/3)

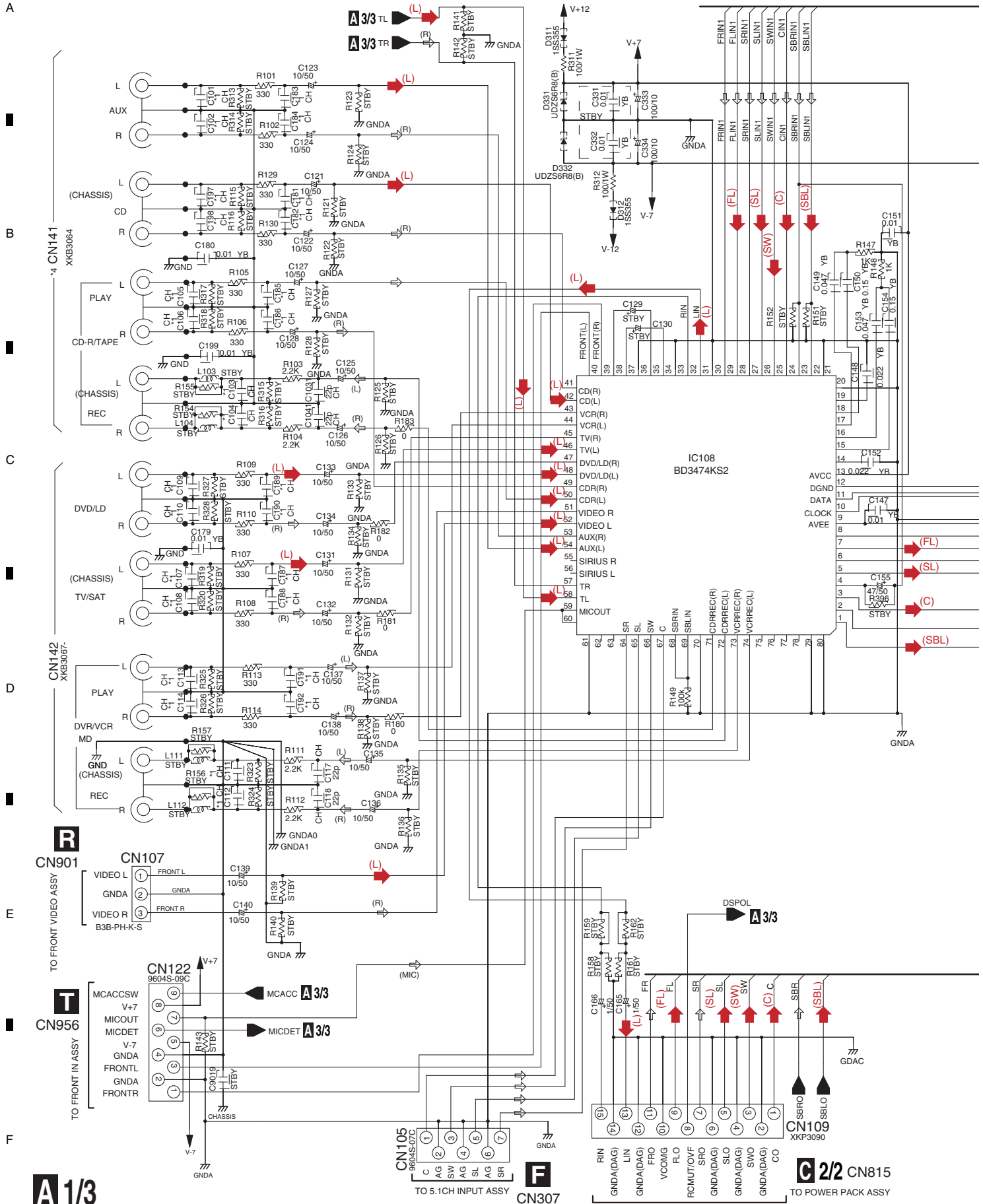

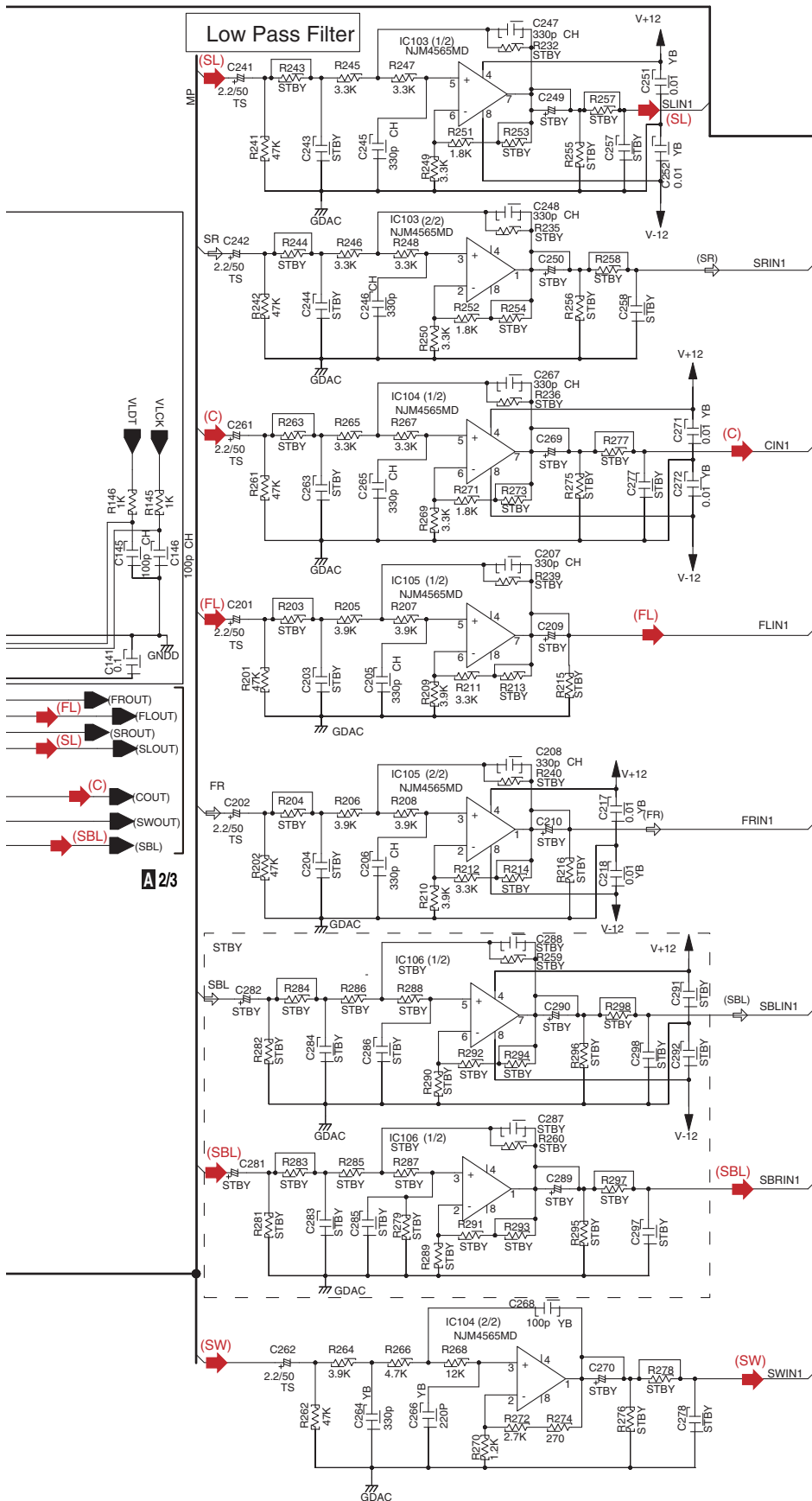

**A 1/3 MAIN ASSY**  
**(VSX-918V:XWK3363)**  
**(VSX-818V:XWK3359)**

NOTES: NO INDICATED PARTS IS...  
 RESISTOR: RS1/16S\*\*\*J-T, RS1/10S\*\*\*J-T  
 CHEMICAL CAPACITOR: CEAT\*\*\*M\*\*-T,-TS  
 CERAMIC CAPACITOR: CCSRCH\*\*\*50-T  
 CKSRYB\*\*\*50-T  
 (SQ):CKSQ.CCSQ  
 ( ) : AUDIO SIGNAL FLOW

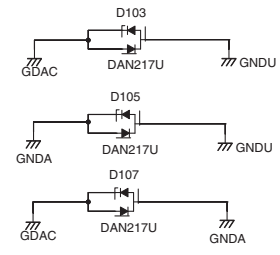
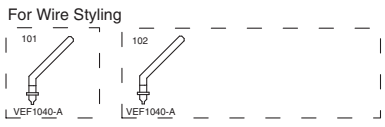

*1	100p	*4	VSX-918V, VSX-818V
		CN141	XKB3064

**MAIN ASSY(1/3)**

- (L) : Audio Signal Route (L ch)
- (M) : Audio Signal Route (Mic ch)
- (FL) : Audio Signal Route (Front L ch)
- (SL) : Audio Signal Route (Surround L ch)
- (C) : Audio Signal Route (Center ch)
- (SBL) : Audio Signal Route (Surround Back L ch)
- (SW) : Audio Signal Route (SubWoofer ch)

# 10.2 MAIN ASSY (2/3)

1

2

3

4

A  
B  
C  
D  
E  
F

## PRE-AMP

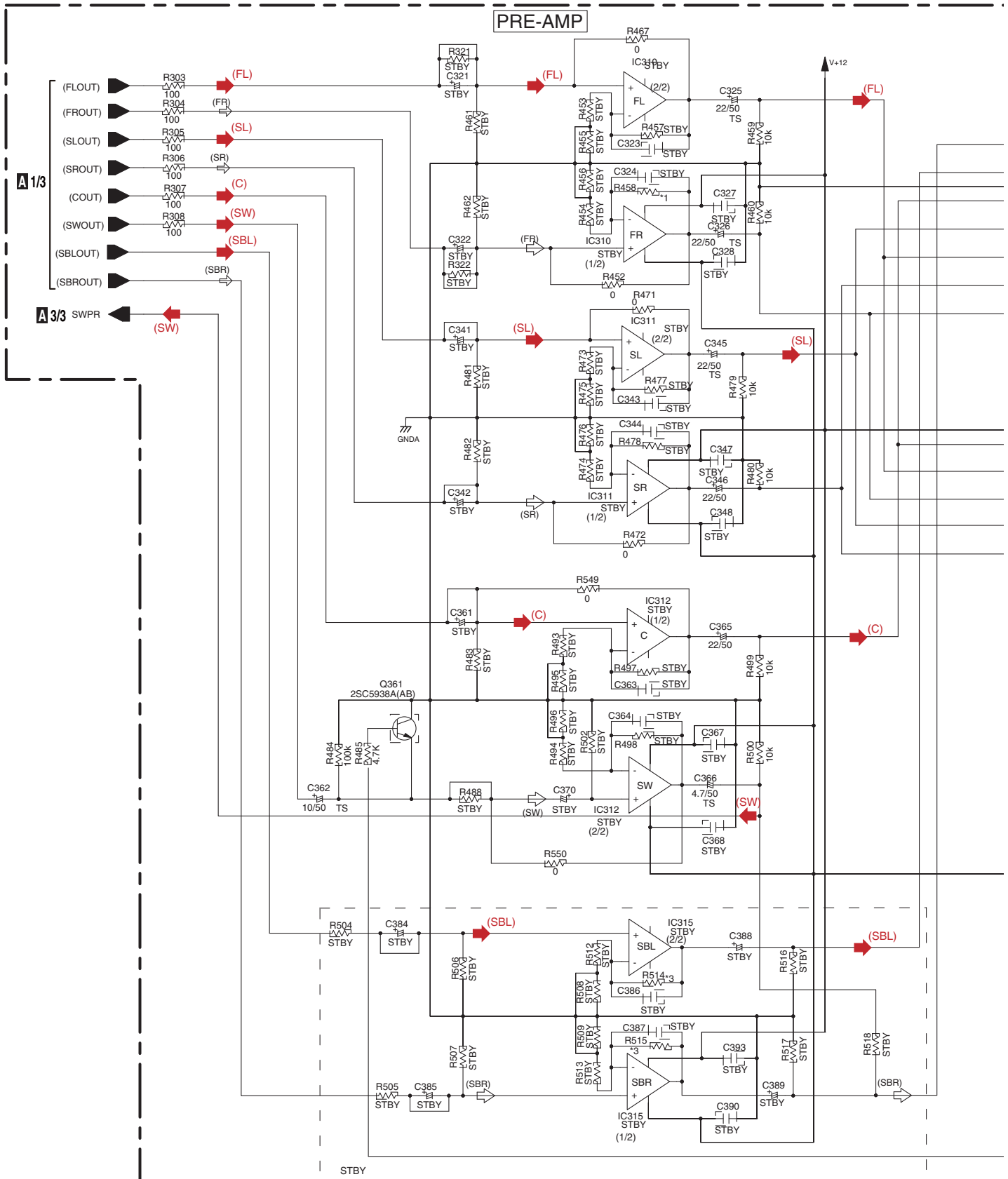

A 2/3

1

2

3

4

**A 2/3** MAIN ASSY  
 (VSX-918V:XWK3363)  
 (VSX-818V:XWK3359)

TO MAIN ASSY  
 (TO MAIN ASSY 3/3)

**A 3/3**

**C 1/2**  
 CN704

TO POWER PACK ASSY

**FAN**  
 TO FAN MOTOR

**G 891**  
 TO TRANS3 ASSY

**J22**  
 XDX3064

**NOTE**  
 1. RESISTORS  
 Unit: k- $\Omega$ , M-M $\Omega$  or  $\Omega$  unless otherwise noted.  
 Rated power: 1/16W unless otherwise noted.  
 Tolerance: (J)  $\pm$  5% unless otherwise noted.  
 2. CAPACITORS  
 Unit: p-pF or  $\mu$ F unless otherwise noted.  
 Ratings: Capacity( $\mu$ F)/Voltage(V) unless otherwise noted.  
 Rated Voltage: 50V expect for electrolytic capacitors.  
 JA:CE:JA  
 : AUDIO SIGNAL FLOW

MAIN ASSY(2/3)

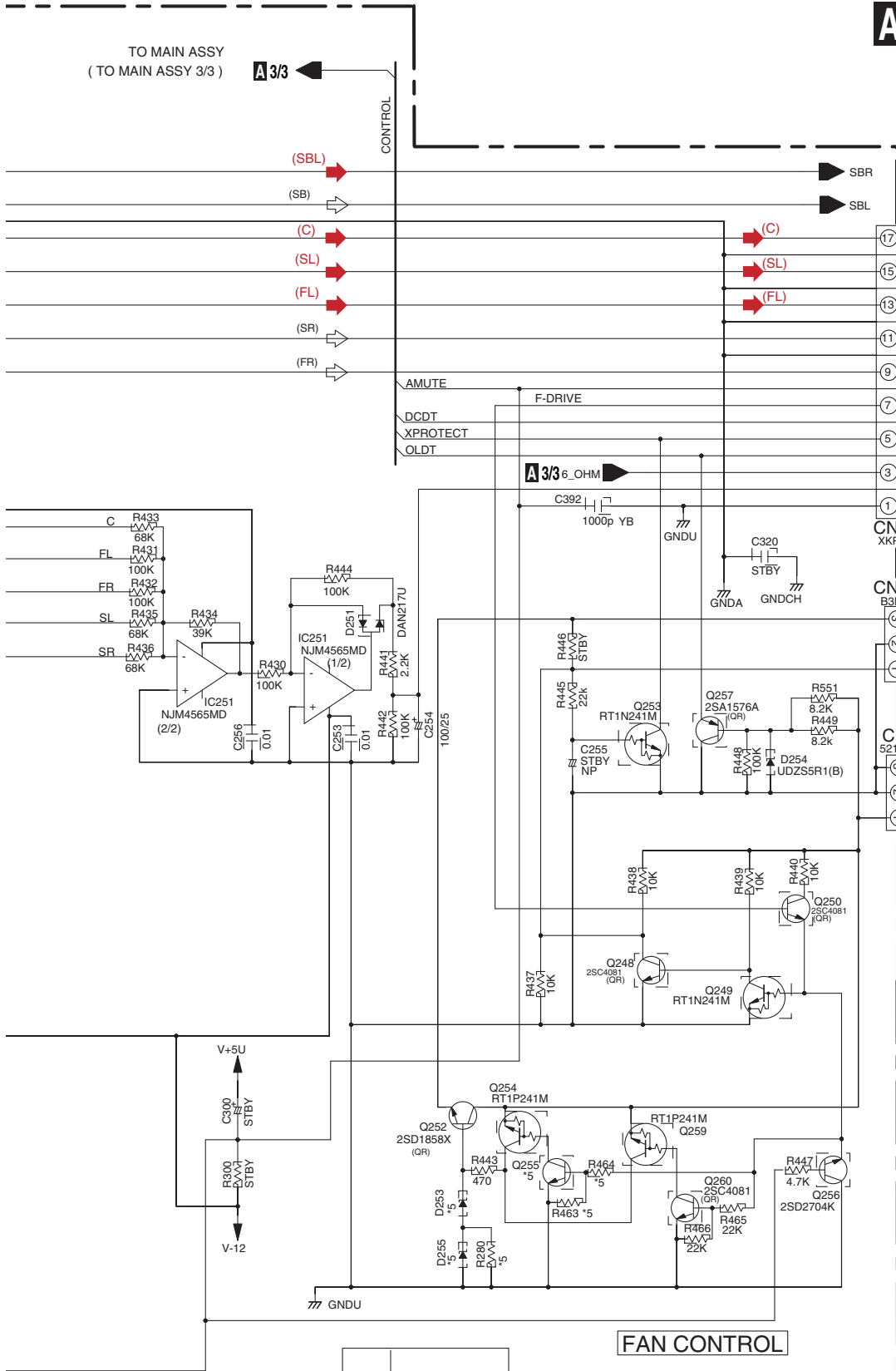

*5	MYSXJ5
D253	UDZS13(B)
D255	UDZS13(B)
R280	-
Q255	2SC4081(QR)
R463	22K
R464	22K

- (FL) : Audio Signal Route (Front L ch)
- (SL) : Audio Signal Route (Surround L ch)
- (C) : Audio Signal Route (Center ch)
- (SBL) : Audio Signal Route (Surround Back L ch)
- (SW) : Audio Signal Route (SubWoofer ch)

**FAN CONTROL**

# 10.3 MAIN ASSY (3/3)

A  
B  
C  
D  
E  
F

P CN304 TO FM/IAM TUNER UNIT  
P CN303 TO VIDEO ASSY

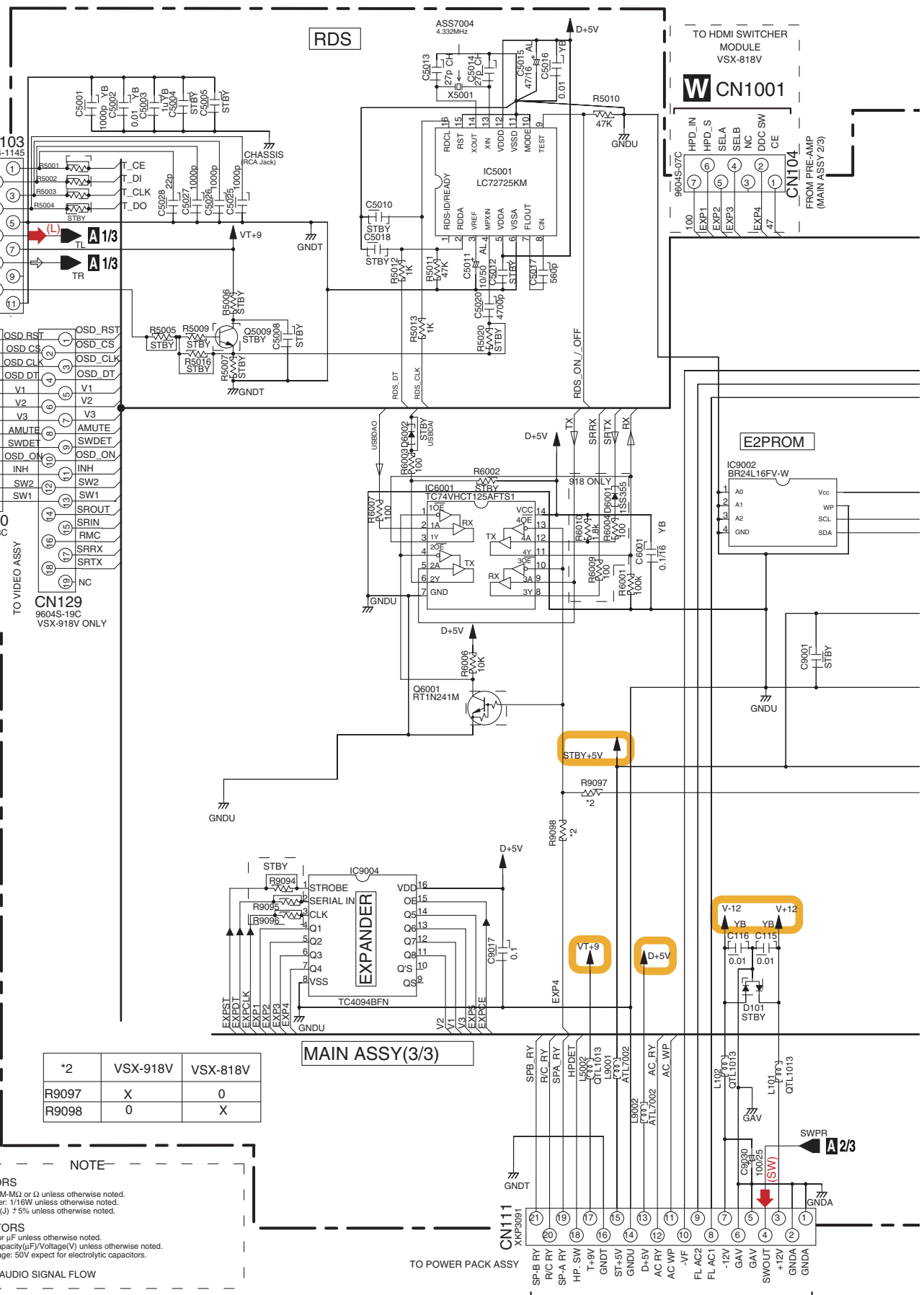

*2	VSX-918V	VSX-818V
R9097	X	0
R9098	0	X

**NOTE**

1. RESISTORS  
Unit: k- $\Omega$ , M- $\Omega$  or  $\Omega$  unless otherwise noted.  
Rated power: 1/16W unless otherwise noted.  
Tolerance: (J)  $\pm$ 5% unless otherwise noted.

2. CAPACITORS  
Unit: p-pF or  $\mu$ F unless otherwise noted.  
Ratings: Capacity( $\mu$ F)/Voltage(V) unless otherwise noted.  
Rated Voltage: 50V except for electrolytic capacitors.

➡ : AUDIO SIGNAL FLOW

**A 3/3**

**C 2/2 CN816**

VSX-918V-K

**A 3/3** MAIN ASSY  
 (VSX-918V:XWK3363)  
 (VSX-818V:XWK3359)

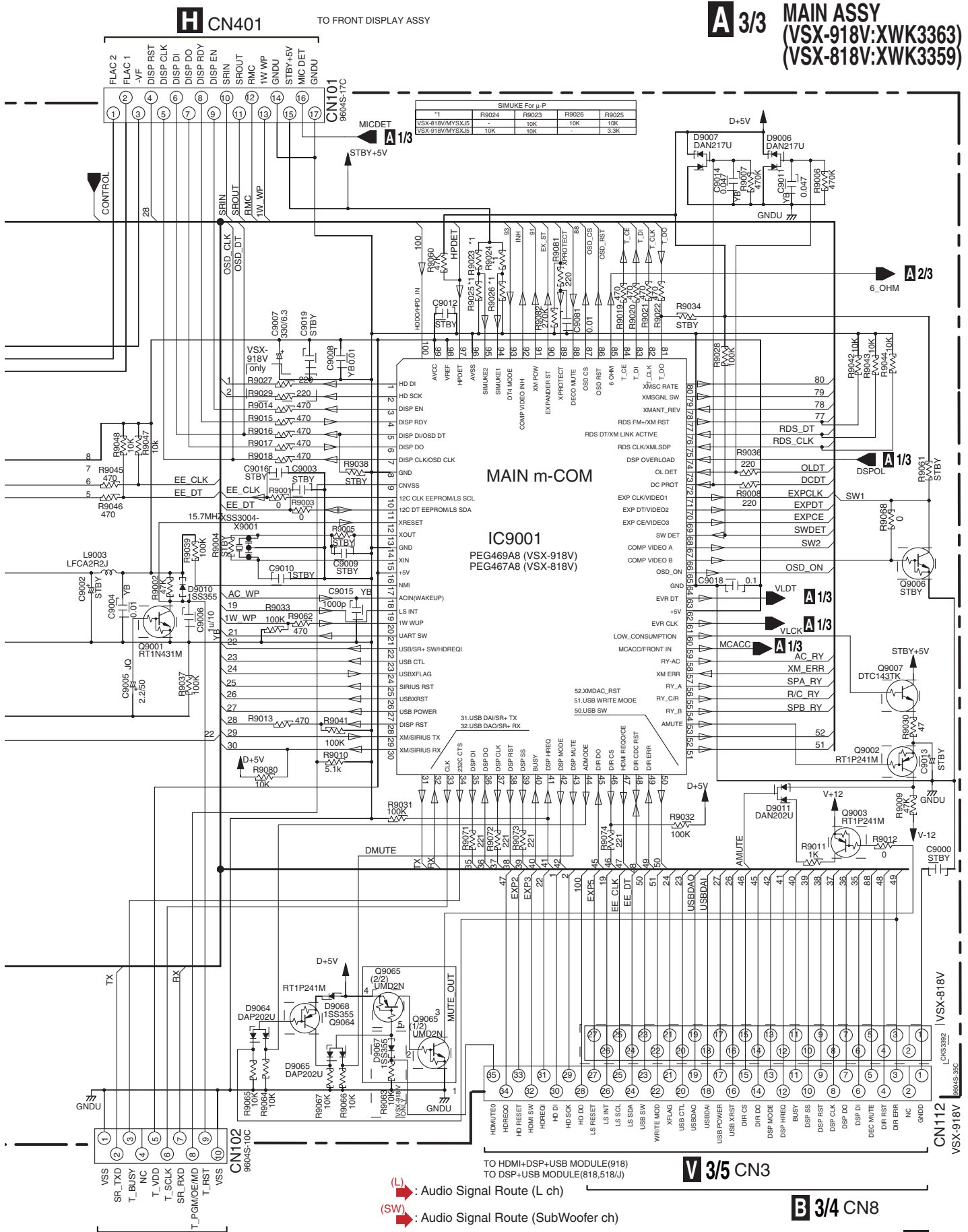

FOR FLASH U-COM 918,818,518/J ONLY  
 FOR FLASH U-COM

(L) : Audio Signal Route (L ch)  
 (SW) : Audio Signal Route (SubWoofer ch)

**V 3/5** CN3

**B 3/4** CN8

**A 3/3**

VSX-918V-K

# 10.4 DSP & USB ASSY (1/4)

## B 1/4 DSP & USB ASSY (VSX-818V:AWX9164)

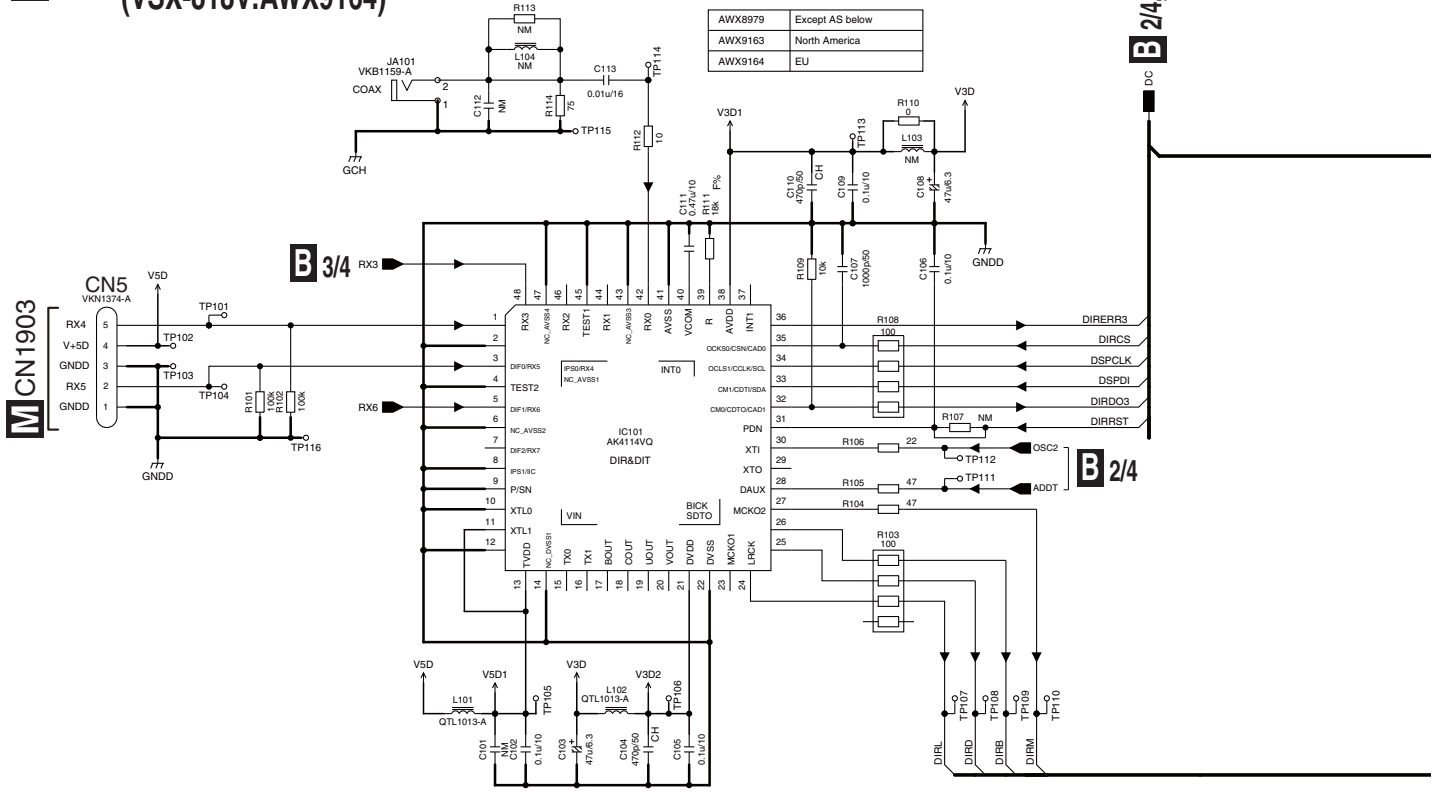

### B 3/4

### B 2/4

### B 2/4,3/4

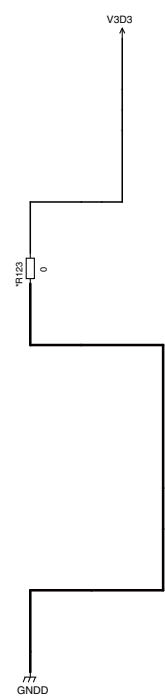

## B 1/4

A  
B  
C  
D  
E  
F

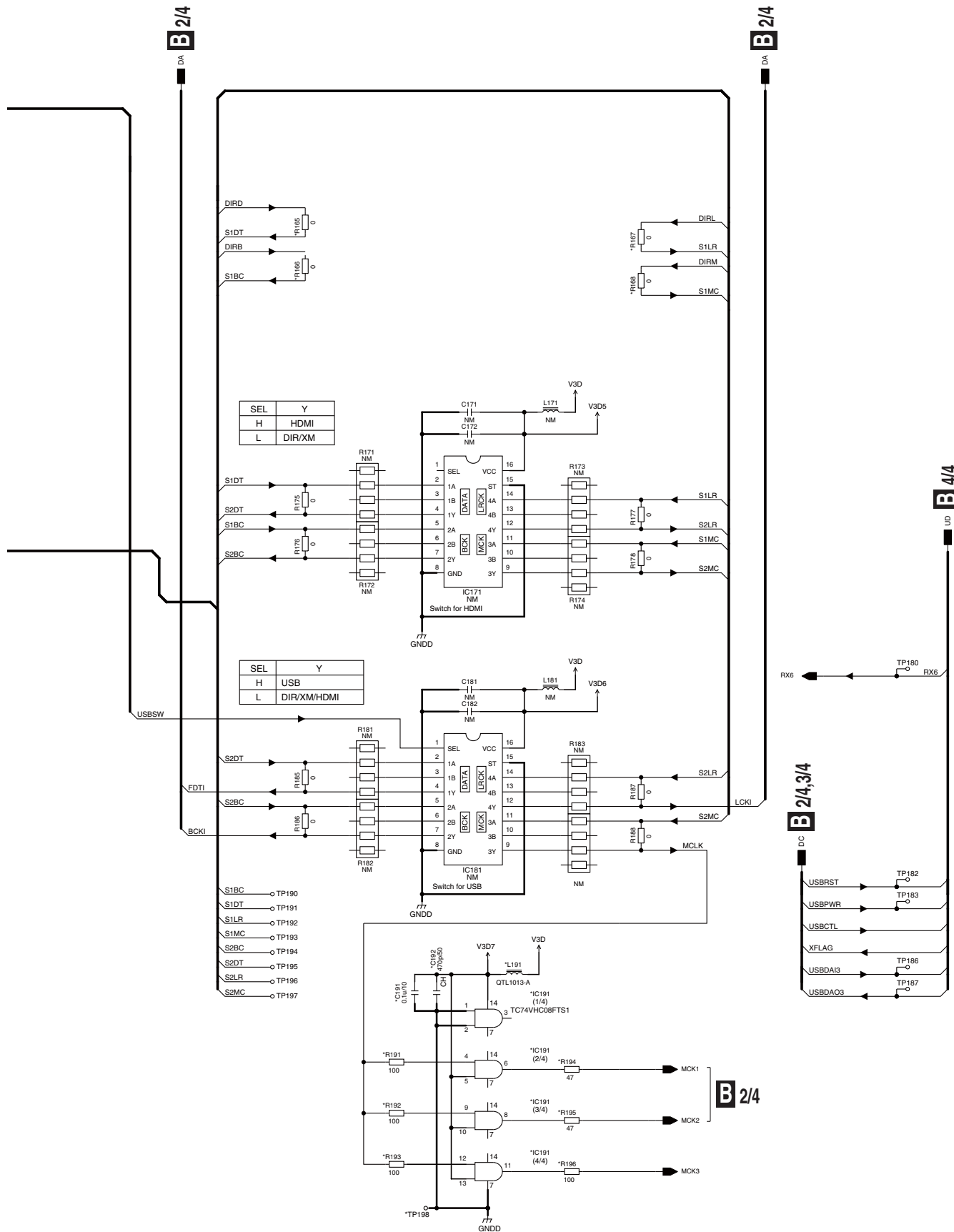

VSX-918V-K



A  
B  
C  
D  
E  
F

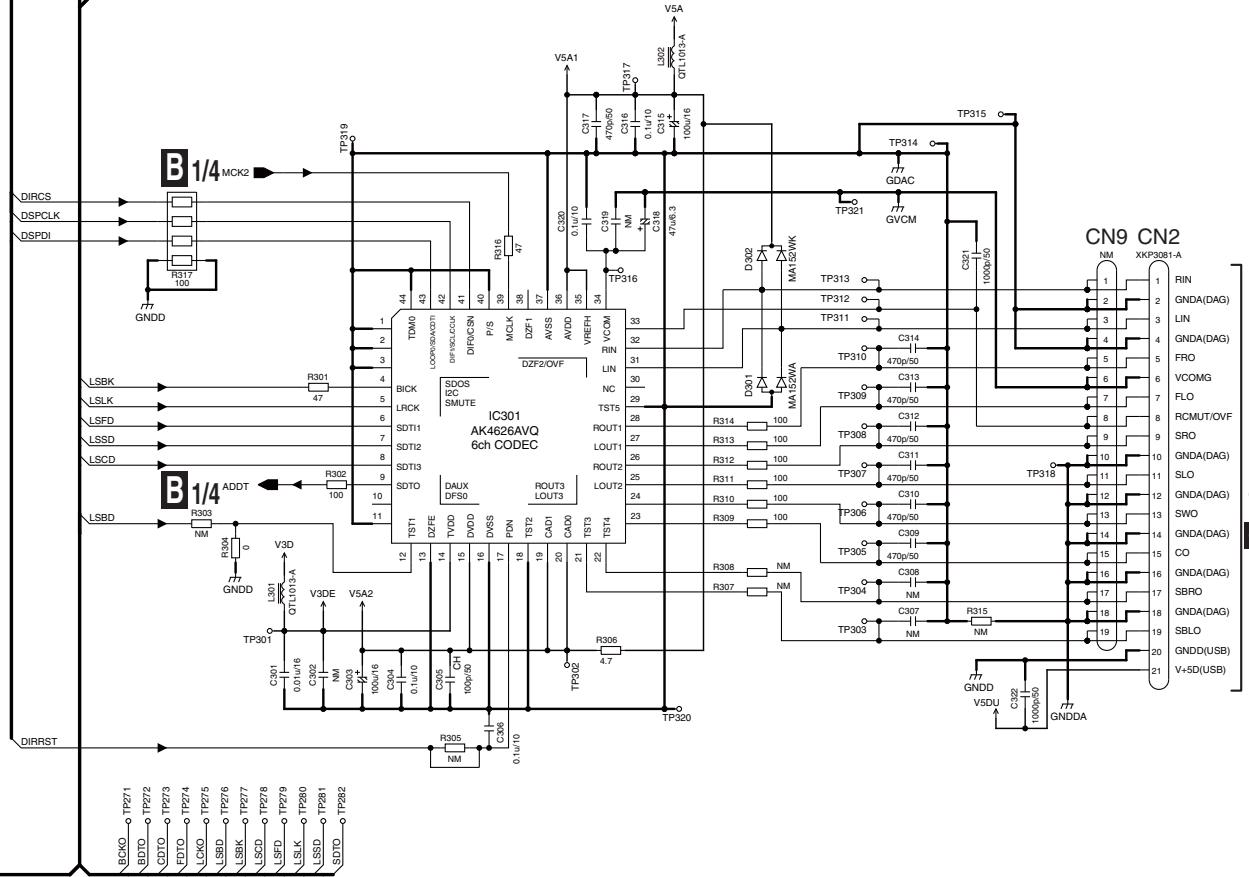
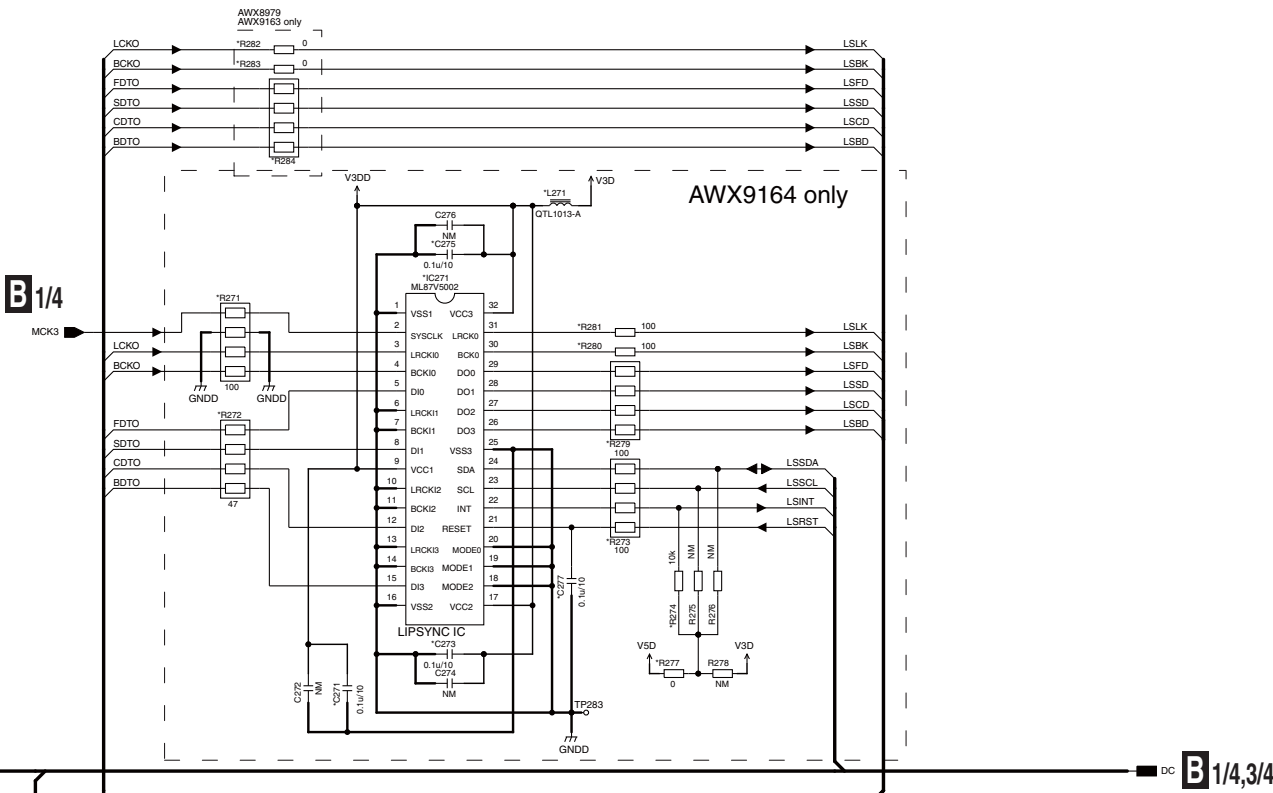

- BCKO → TP271
- SDTO → TP272
- CDTO → TP273
- FDTO → TP274
- LCKO → TP275
- LSBK → TP276
- LSKD → TP277
- LSFD → TP278
- LSSD → TP279
- LSLK → TP280
- SDTO → TP281
- SDTO → TP282

**B 2/4**

# 10.6 DSP & USB ASSY (3/4)

## B 3/4 DSP & USB ASSY (VSX-818V:AWX9164)

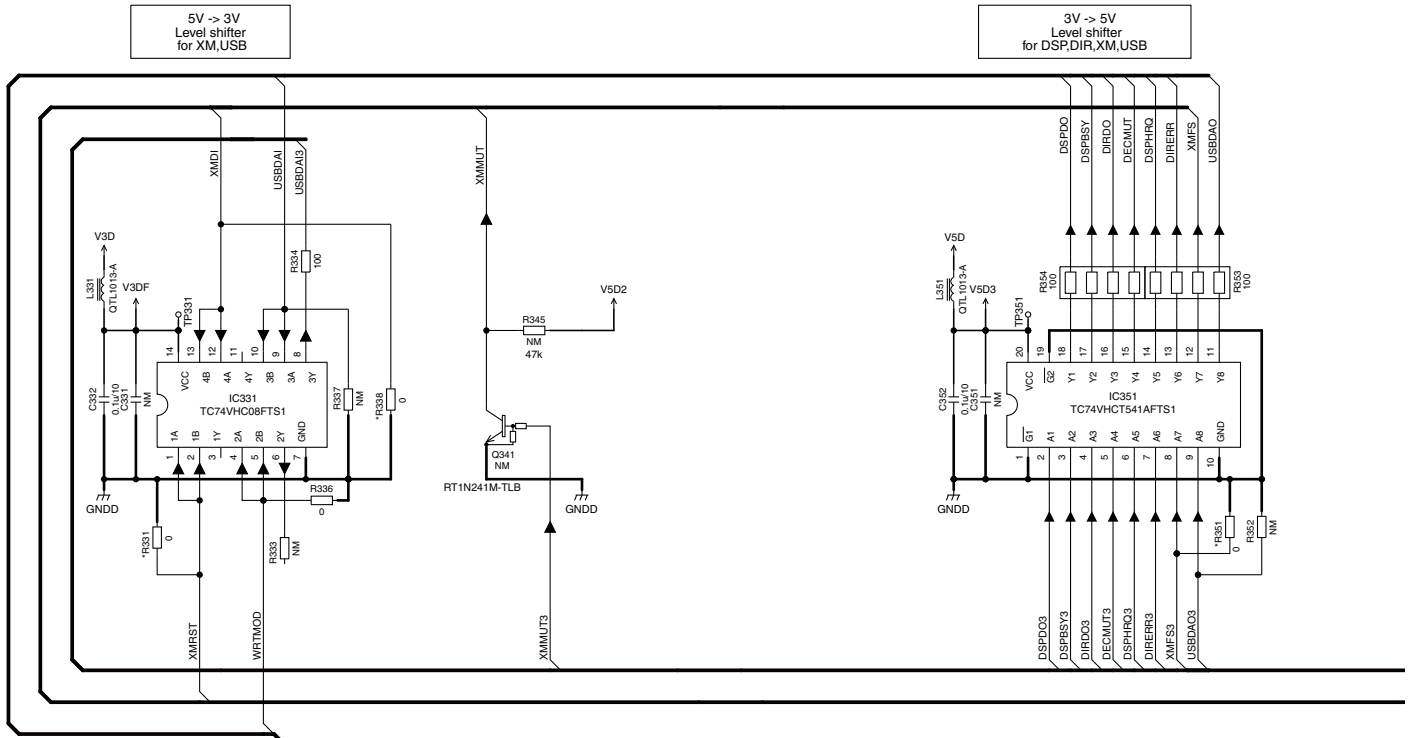

D

E

F

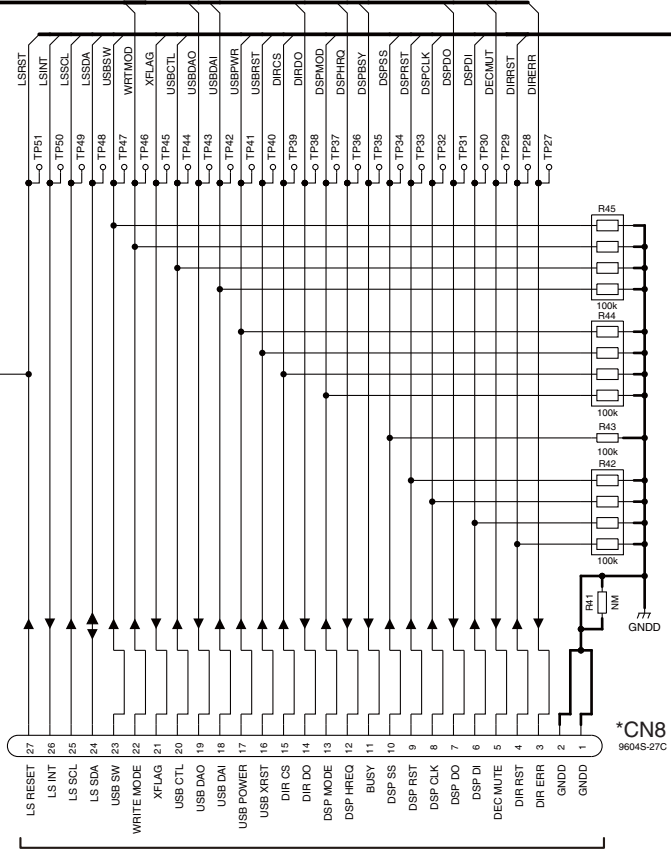

## A 3/3 CN112

## B 3/4











# 10.9 POWER PACK ASSY (2/2)

- (L) : Audio Signal Route (L ch)
- (FL) : Audio Signal Route (Front L ch)
- (SL) : Audio Signal Route (Surround L ch)
- (C) : Audio Signal Route (Center ch)
- (SW) : Audio Signal Route (SubWoofer ch)

## C 2/2 POWER PACK ASSY (XWZ4326)

A  
B  
C  
D  
E  
F

B 2/4 CN2 V 2/5 CN2  
B 3/4 CN1 V 3/5 CN1

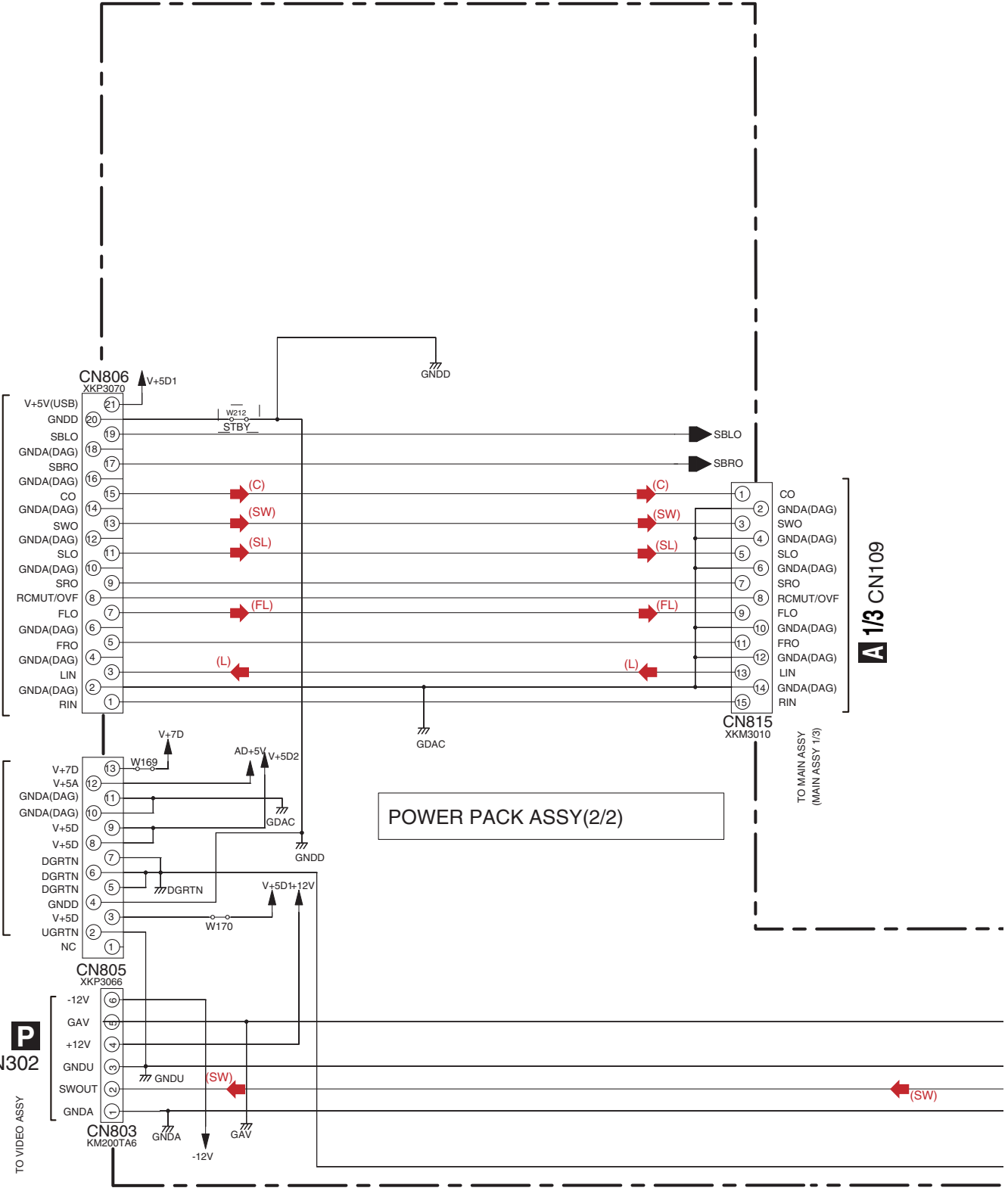

A 1/3 CN109

TO MAIN ASSY (MAIN ASSY 1/3)

C 2/2

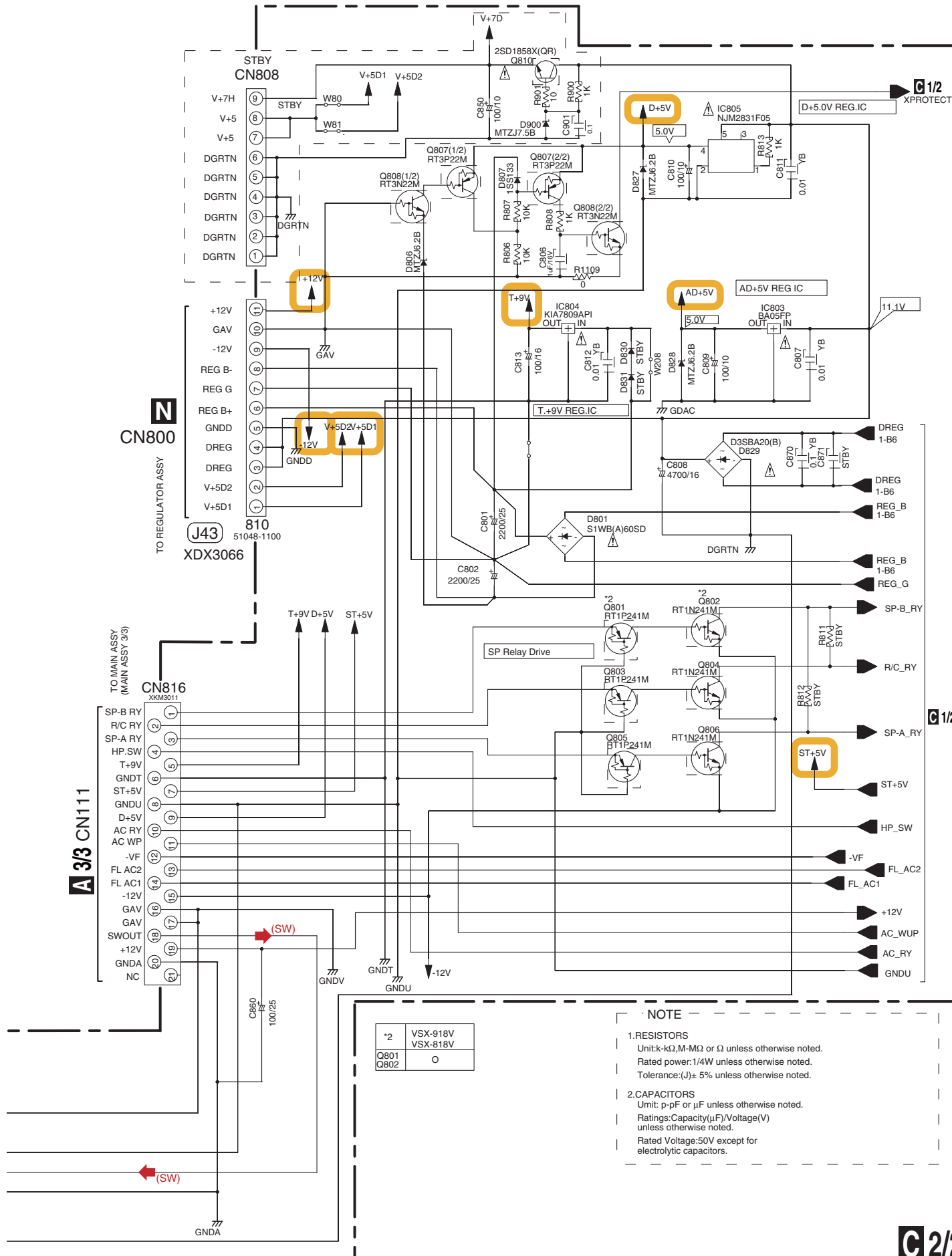

*2	VSX-918V
	VSX-818V
Q801	
Q802	0

**NOTE**

- RESISTORS**  
Unit:k- $\Omega$ ,M- $\Omega$  or  $\Omega$  unless otherwise noted.  
Rated power:1/4W unless otherwise noted.  
Tolerance:(J) $\pm$  5% unless otherwise noted.
- CAPACITORS**  
Unit: p-pF or  $\mu$ F unless otherwise noted.  
Ratings:Capacity( $\mu$ F)/Voltage(V) unless otherwise noted.  
Rated Voltage:50V except for electrolytic capacitors.

# 10.10 COMPONENT VIDEO, 5.1CH INPUT and TRANS3 ASSYS

A

B

C

D

E

F

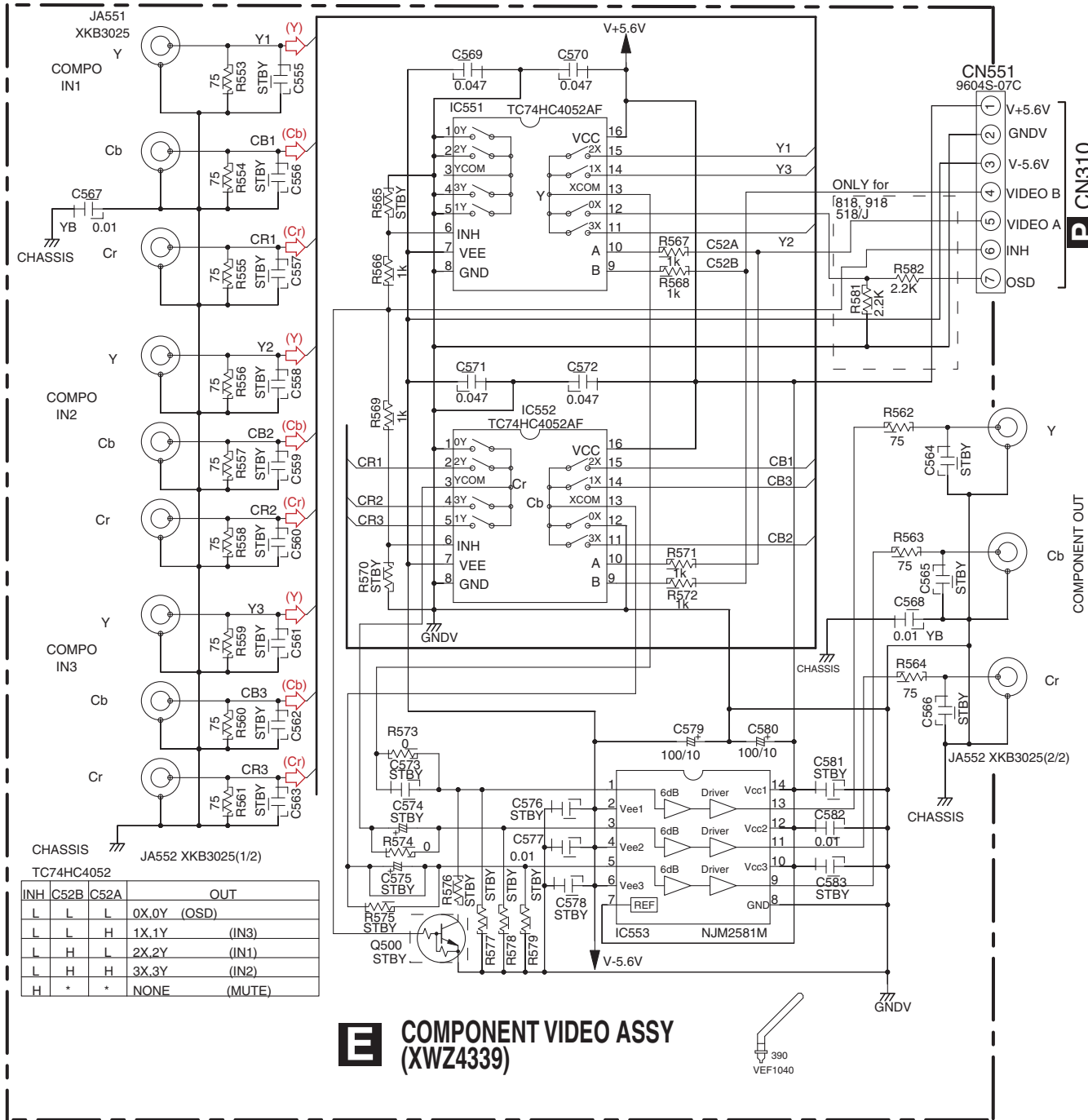

**COMPONENT VIDEO ASSY (XWZ4339)**

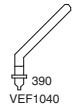

**NOTE**

- 1.RESISTORS**  
Unit: k-kΩ, M-MΩ or Ω unless otherwise noted.  
Rated power: 1/16W unless otherwise noted.  
Tolerance: (J) ± 5% unless otherwise noted.
- 2.CAPACITORS**  
Unit: p-pF or μF unless otherwise noted.  
Ratings: Capacity(μF)/Voltage(V) unless otherwise noted.  
Rated Voltage: 50V expect for electrolytic capacitors.

- (Y) Video Signal Route (Component Y ch)
- (Cb) Video Signal Route (Component Cb ch)
- (Cr) Video Signal Route (Component Cr ch)



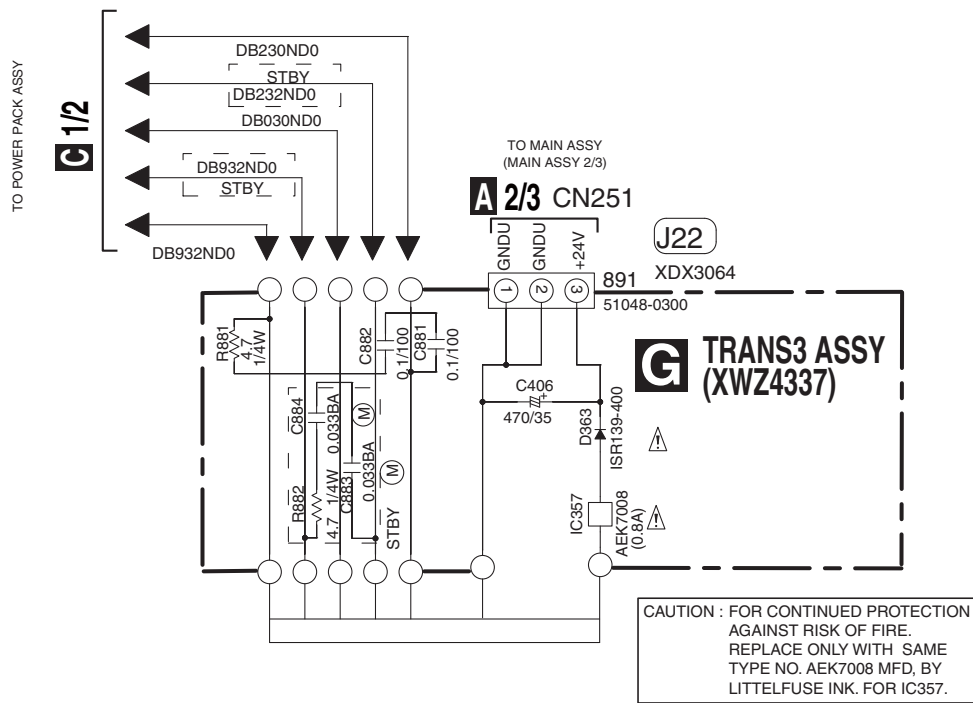
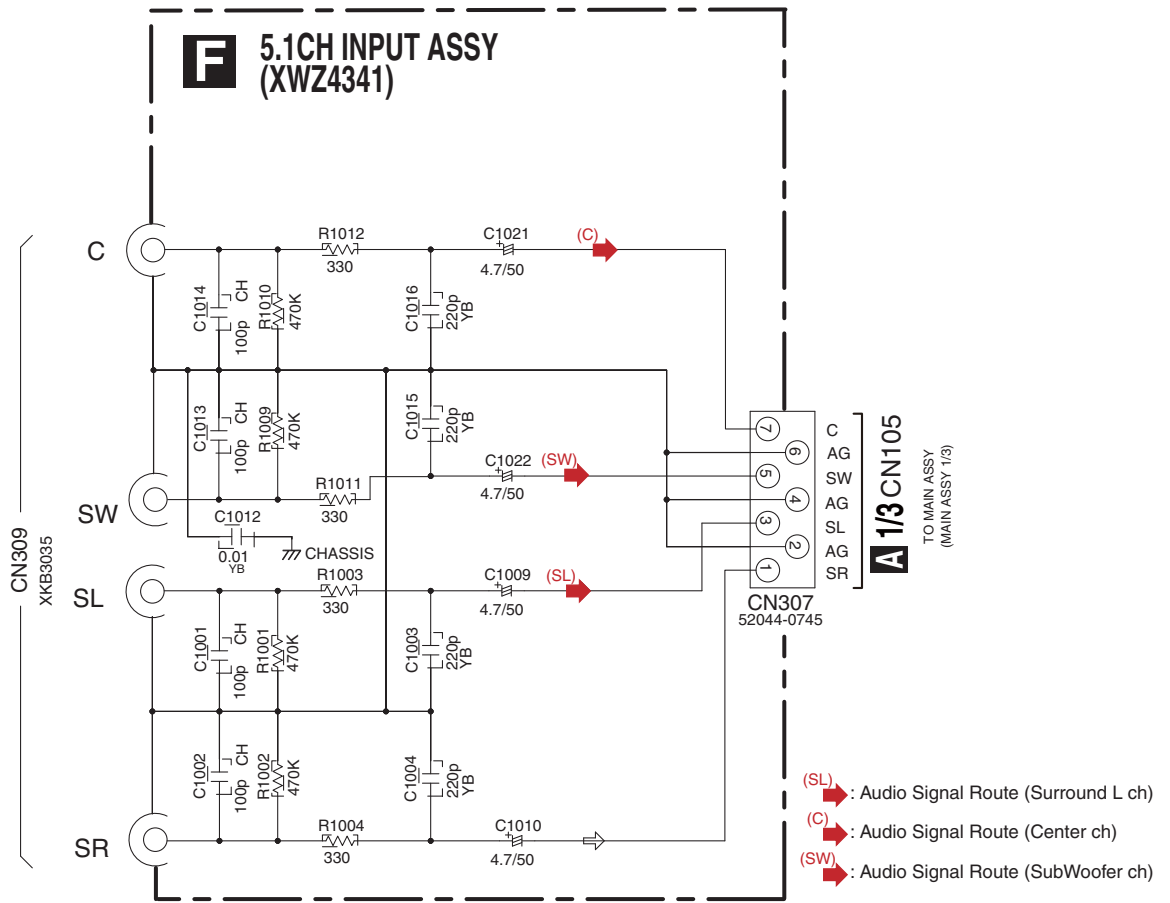



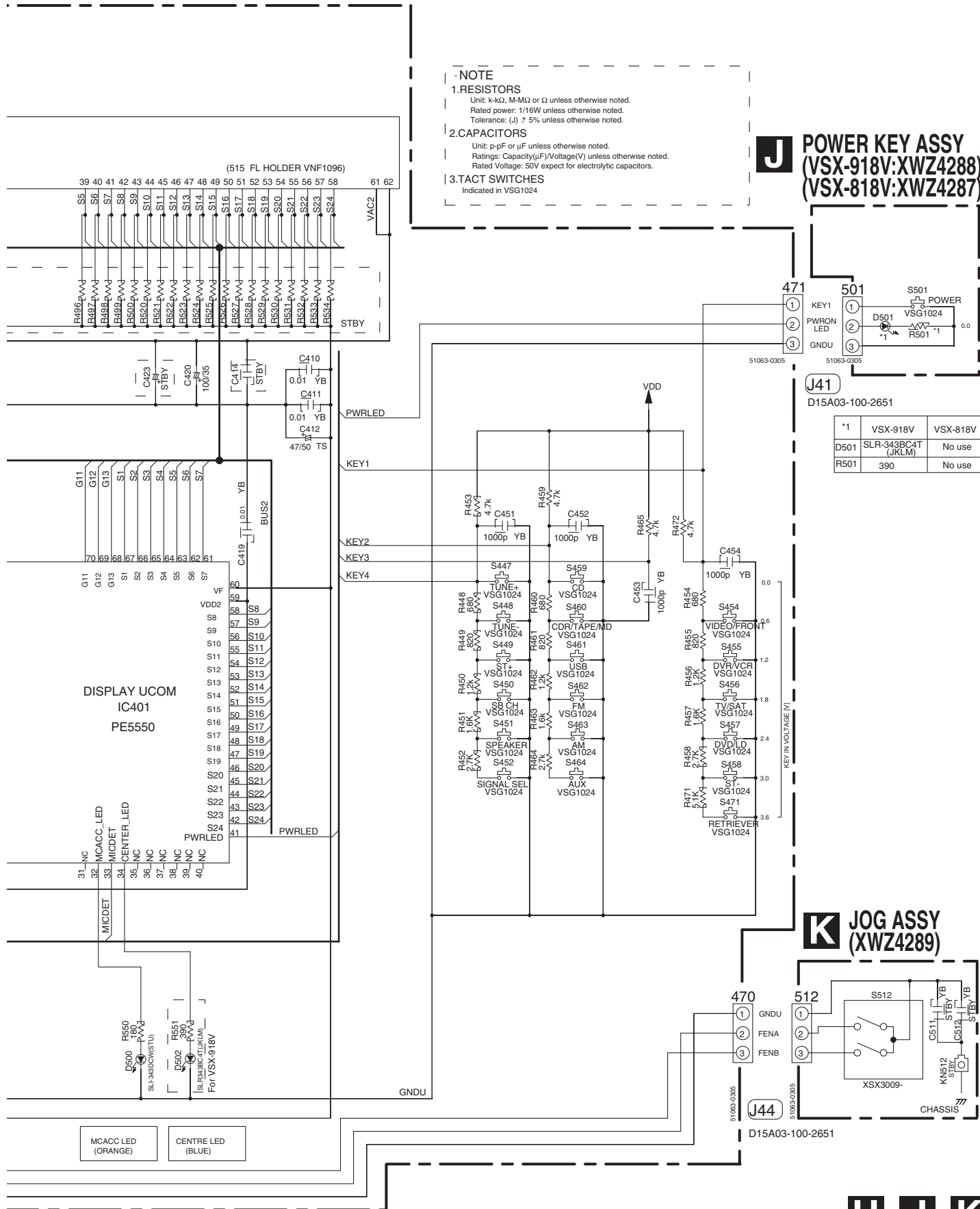

**NOTE**

1. RESISTORS  
 Unit: k-Ω, M-Ω or Ω unless otherwise noted.  
 Rated power: 1/16W unless otherwise noted.  
 Tolerance: (J) ± 5% unless otherwise noted.

2. CAPACITORS  
 Unit: p-pF or μF unless otherwise noted.  
 Ratings: Capacity(μF)/Voltage(V) unless otherwise noted.  
 Rated Voltage: 50V expect for electrolytic capacitors.

3. TACT SWITCHES  
 Indicated in VSG1024

**J POWER KEY ASSY (VSX-918V: XWZ4288) (VSX-818V: XWZ4287)**

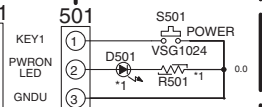

**J41**  
D15A03-100-2651

*1	VSX-918V	VSX-818V
D501	SLR-343BC4T (JKLM)	No use
R501	390	No use

**K JOG ASSY (XWZ4289)**

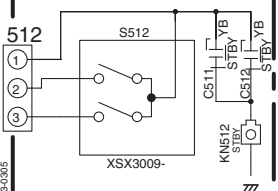

# 10.12 DIGITAL INPUT, REGULATOR and HEAD PHONE ASSYS

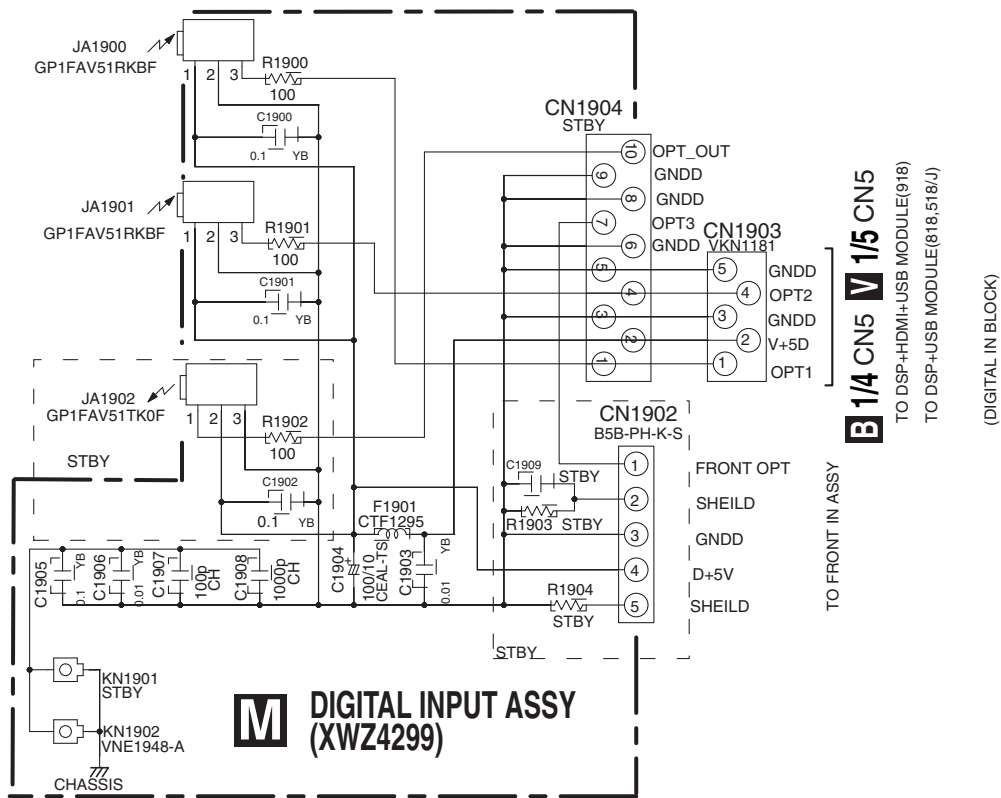

**B 1/4 CN5 V 1/5 CN5**  
 TO DSP+HDMI+USB MODULE(918)  
 TO DSP+USB MODULE(818,518/J)

(DIGITAL IN BLOCK)

TO FRONT IN ASSY

**M** DIGITAL INPUT ASSY  
 (XWZ4299)

**NOTE**

**1.RESISTORS**

Unit: k-k $\Omega$ , M-M $\Omega$  or  $\Omega$  unless otherwise noted.  
 Rated power: 1/16W unless otherwise noted.  
 Tolerance: (J)  $\pm$  5% unless otherwise noted.

**2.CAPACITORS**

Unit: p-pF or  $\mu$ F unless otherwise noted.  
 Ratings: Capacity( $\mu$ F)/Voltage(V) unless otherwise noted.  
 Rated Voltage: 50V expect for electrolytic capacitors.



TO POWER PACK ASSY

**C** 2/2 810

*1	VSX-918V VSX-818V
IC809	-
C809	-
C810	-
R809	-
R810	-
R820	-
D814	-
IC807	BA50BCOT
R819	O(0)
C817	O
C816	O
D813	O
IC808	BA50BCOT
W376	O
W379	-
W380	-
W378	O

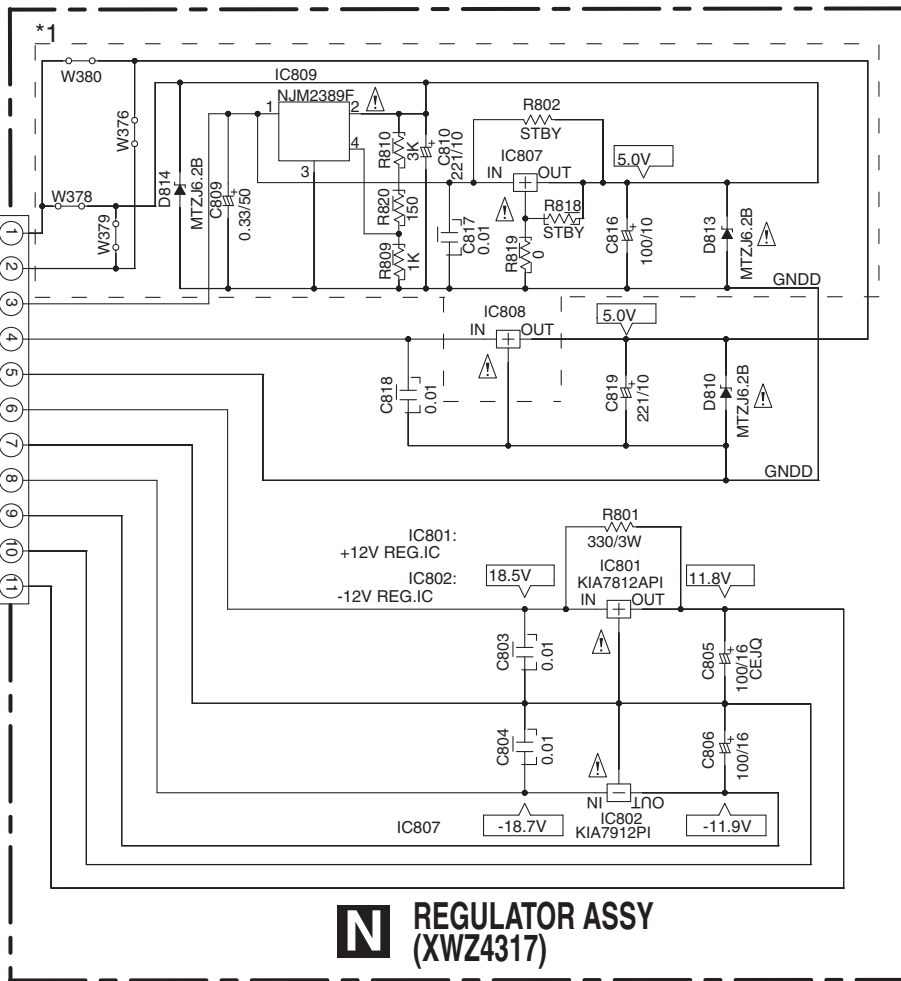

**N** REGULATOR ASSY (XWZ4317)

TO POWER PACK ASSY

**C** 1/2 CN702

1551  
51048-0600

**J47**  
XDX3065

**O** HEAD PHONE ASSY (XWZ4321)

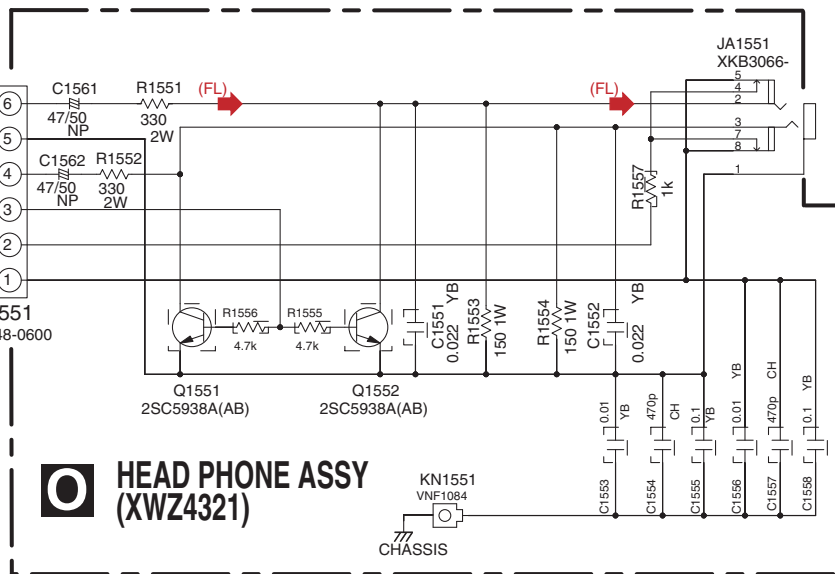

(FL) : Audio Signal Route (Front L ch)

VSX-918V-K

**N** **O**

# 10.13 VIDEO, PRIMARY and FRONT VIDEO ASSYS

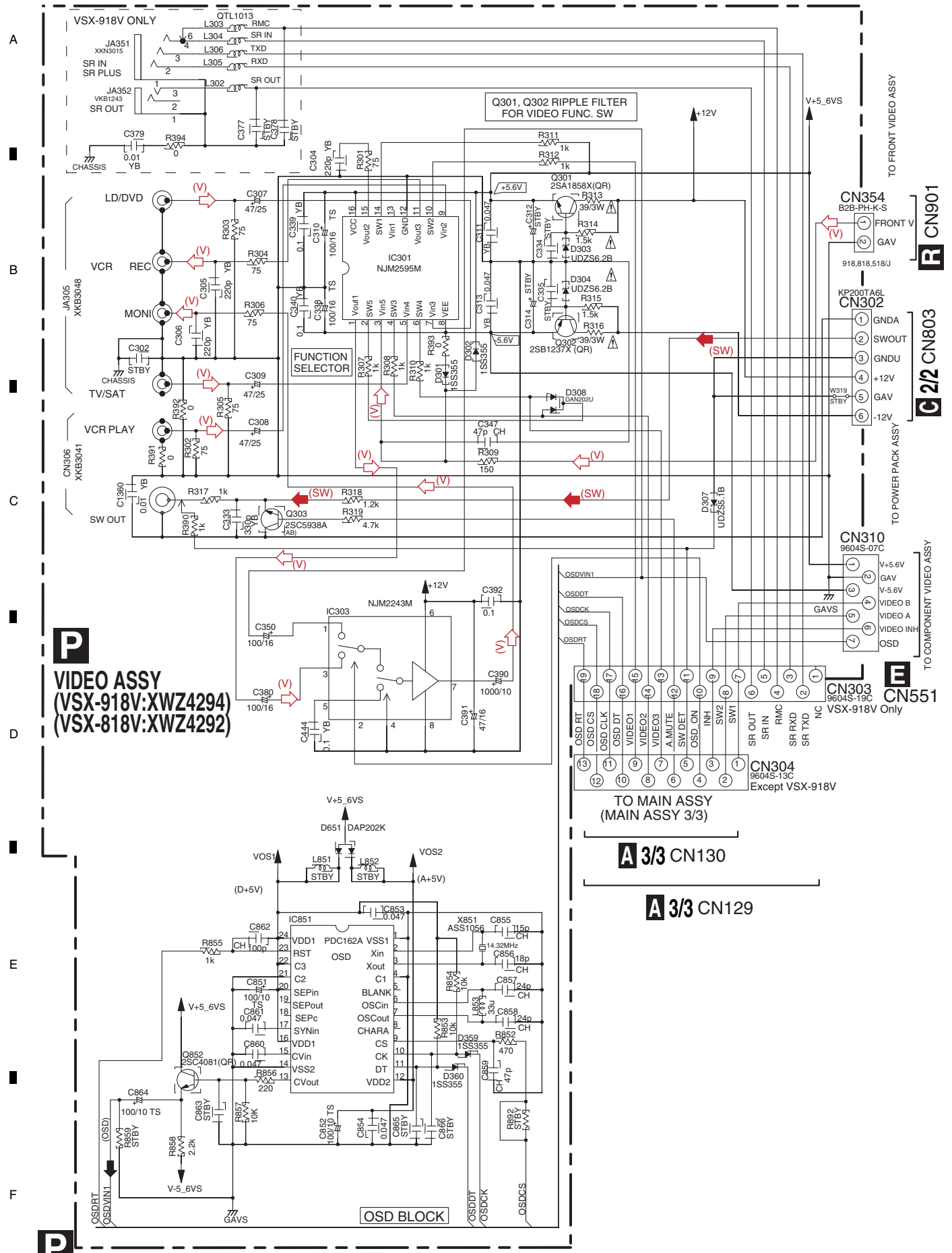

**P**  
**VIDEO ASSY**  
 (VSX-918V: XWZ4294)  
 (VSX-818V: XWZ4292)

**E**  
**CN303**  
 9604S-19C  
 VSX-918V Only

**E**  
**CN551**

**CN310**  
 9604S-07C

**CN304**  
 9604S-13C  
 Except VSX-918V

**CN302**  
 KP200TA6L

**CN354**  
 B2B-PH-K-S

**A 3/3** CN130

**A 3/3** CN129

**TO MAIN ASSY (MAIN ASSY 3/3)**

**TO COMPONENT VIDEO ASSY**

**TO POWER PACK ASSY**

**TO FRONT VIDEO ASSY**

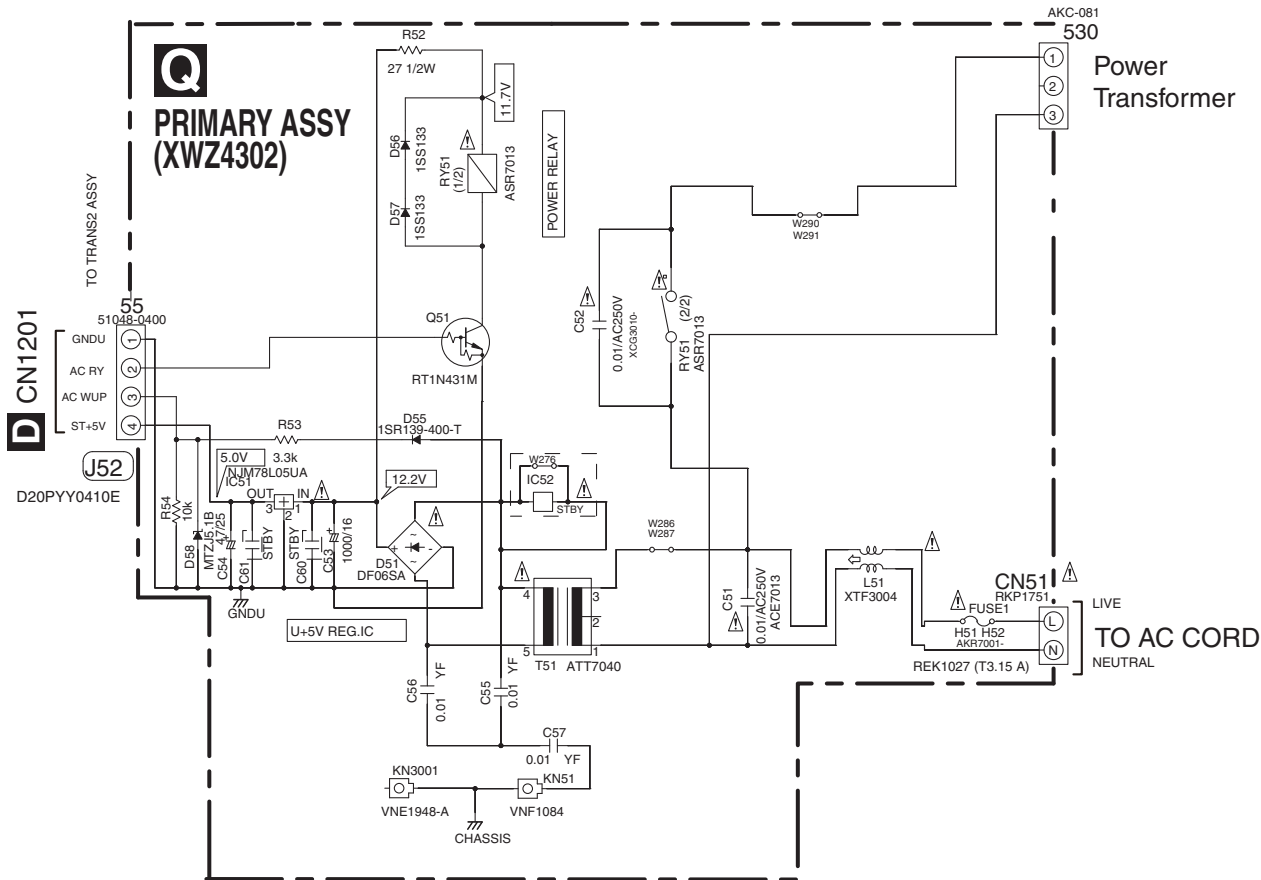

• NOTE FOR FUSE REPLACEMENT

**CAUTION** - FOR CONTINUED PROTECTION AGAINST RISK OF FIRE. REPLACE WITH SAME TYPE AND RATINGS OF FUSE.

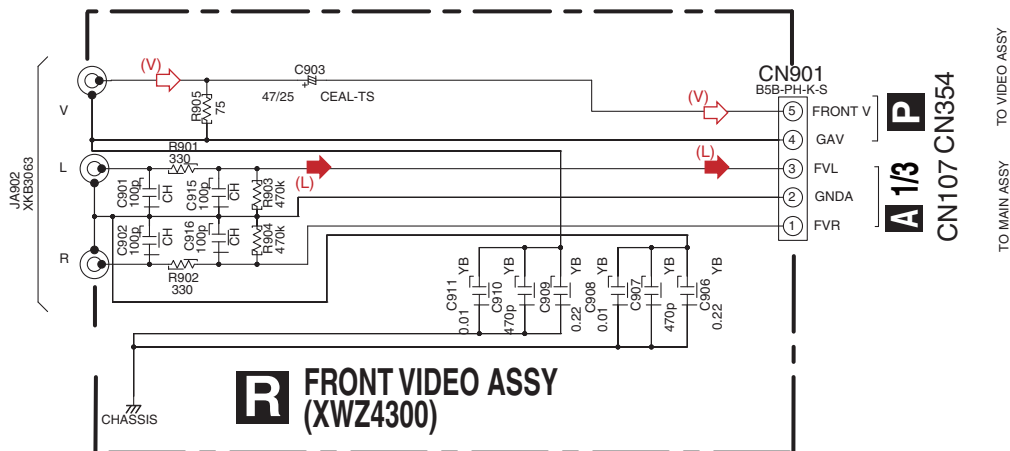

**NOTE**

1. RESISTORS  
Unit: k-kΩ, M-MΩ or Ω unless otherwise noted.  
Rated power: 1/16W unless otherwise noted.  
Tolerance: (J) ± 5% unless otherwise noted.

2. CAPACITORS  
Unit: p-pF or μF unless otherwise noted.  
Ratings: Capacity(μF)/Voltage(V) unless otherwise noted.  
Rated Voltage: 50V expect for electrolytic capacitors.

(V) : Video Signal Route

(L) : Audio Signal Route (L ch)

(SW) : Audio Signal Route (SubWoofer ch)

# 10.14 FRONT IN ASSY

## FRONT IN ASSY (XWZ3366)

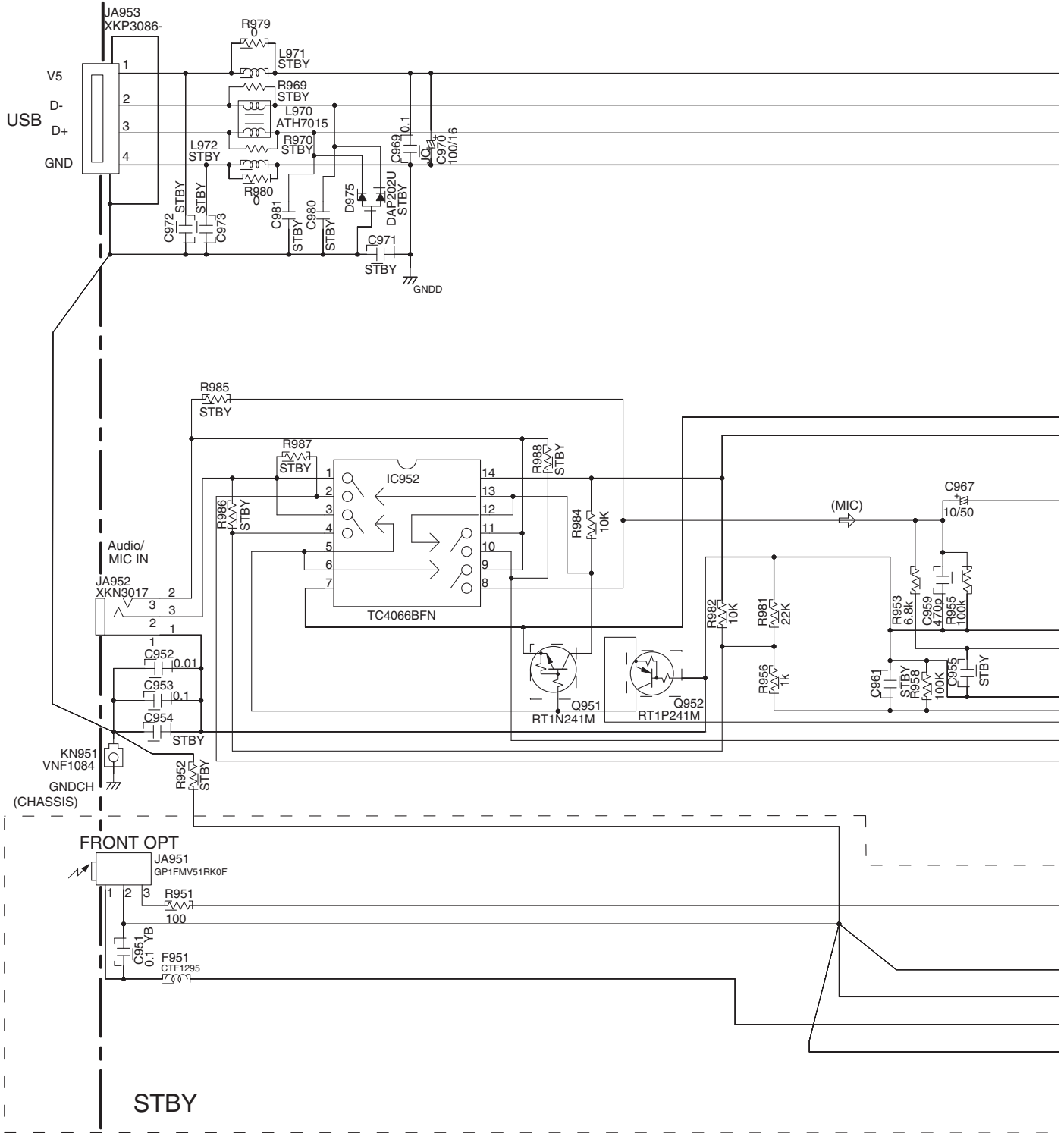

STBY

### NOTE

1. RESISTORS  
Unit: k-kΩ, M-MΩ or Ω unless otherwise noted.  
Rated power: 1/16W unless otherwise noted.  
Tolerance: (J) 5% unless otherwise noted.
2. CAPACITORS  
Unit: p-pF or μF unless otherwise noted.  
Ratings: Capacity(μF)/Voltage(V) unless otherwise noted.  
Rated Voltage: 50V expect for electrolytic capacitors.



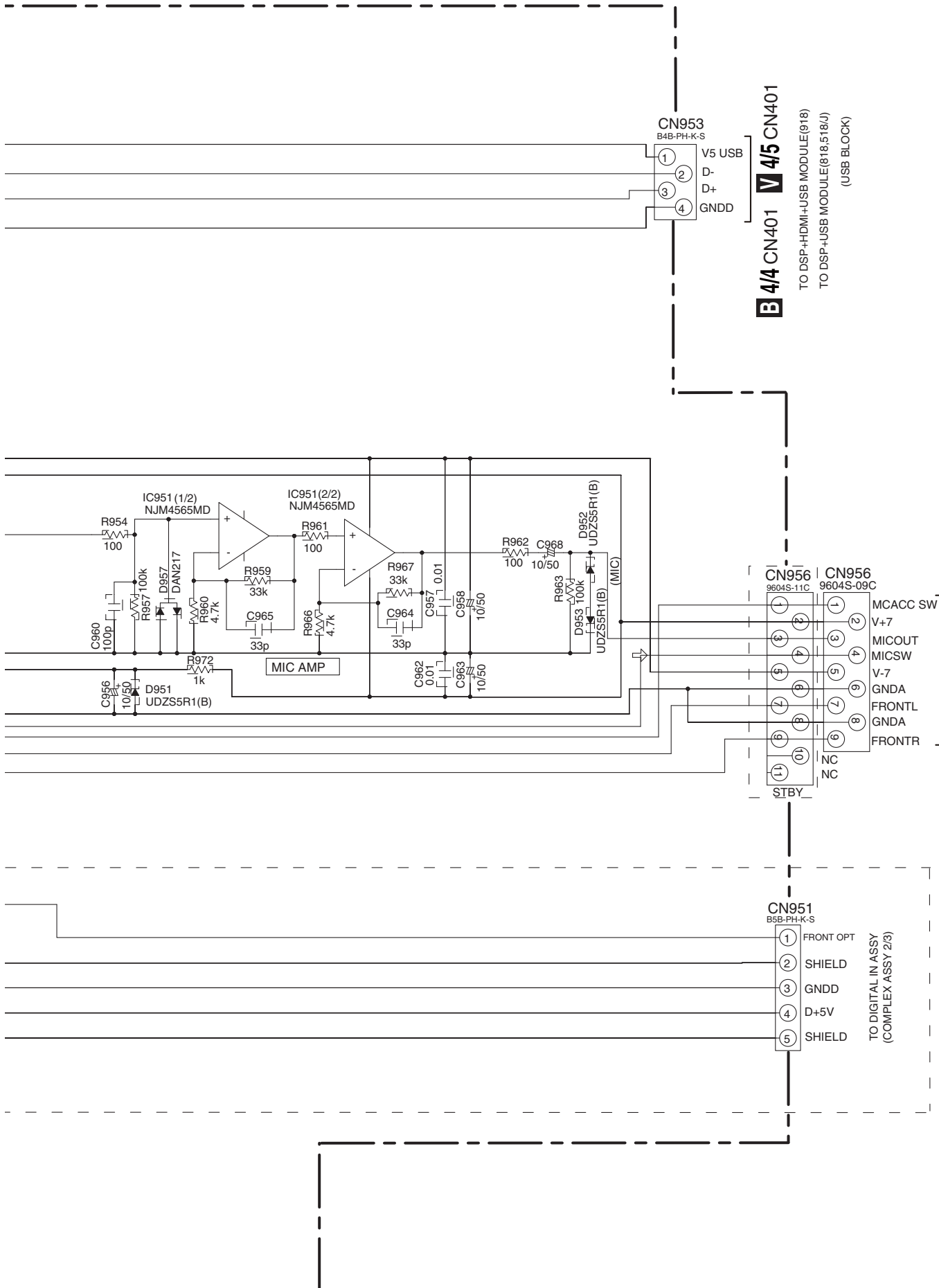

**B 4/4 CN401** **V 4/5 CN401**

TO DSP+HDMI+USB MODULE(918)  
TO DSP+USB MODULE(818:518/J)  
(USB BLOCK)

**A 1/3 CN122**

TO MAIN ASSY  
(MAIN ASSY 1/3)

CN951  
B5B-PH-K-S

- ① FRONT OPT
- ② SHIELD
- ③ GNDD
- ④ D+5V
- ⑤ SHIELD

TO DIGITAL IN ASSY  
(COMPLEX ASSY 2/3)

# 10.15 HDMI & DSP & USB ASSY (1/5)

## V 1/5 HDMI & DSP & USB ASSY (VSX-918V:AWX8977)

AWX8977	Except as below
AWX9162	North America

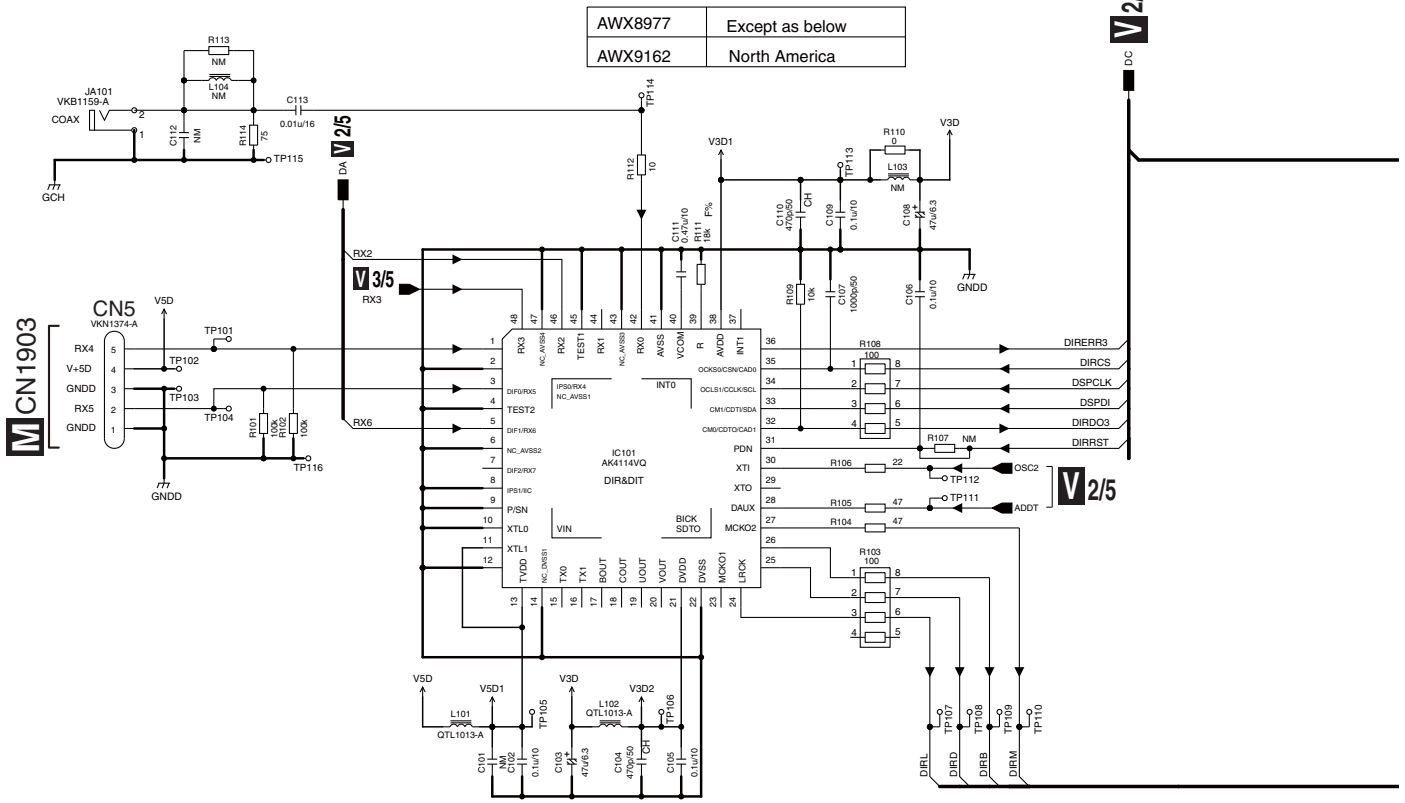

V 2/5,3/5 DC

V 2/5

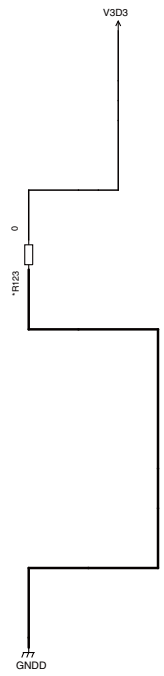

## V 1/5

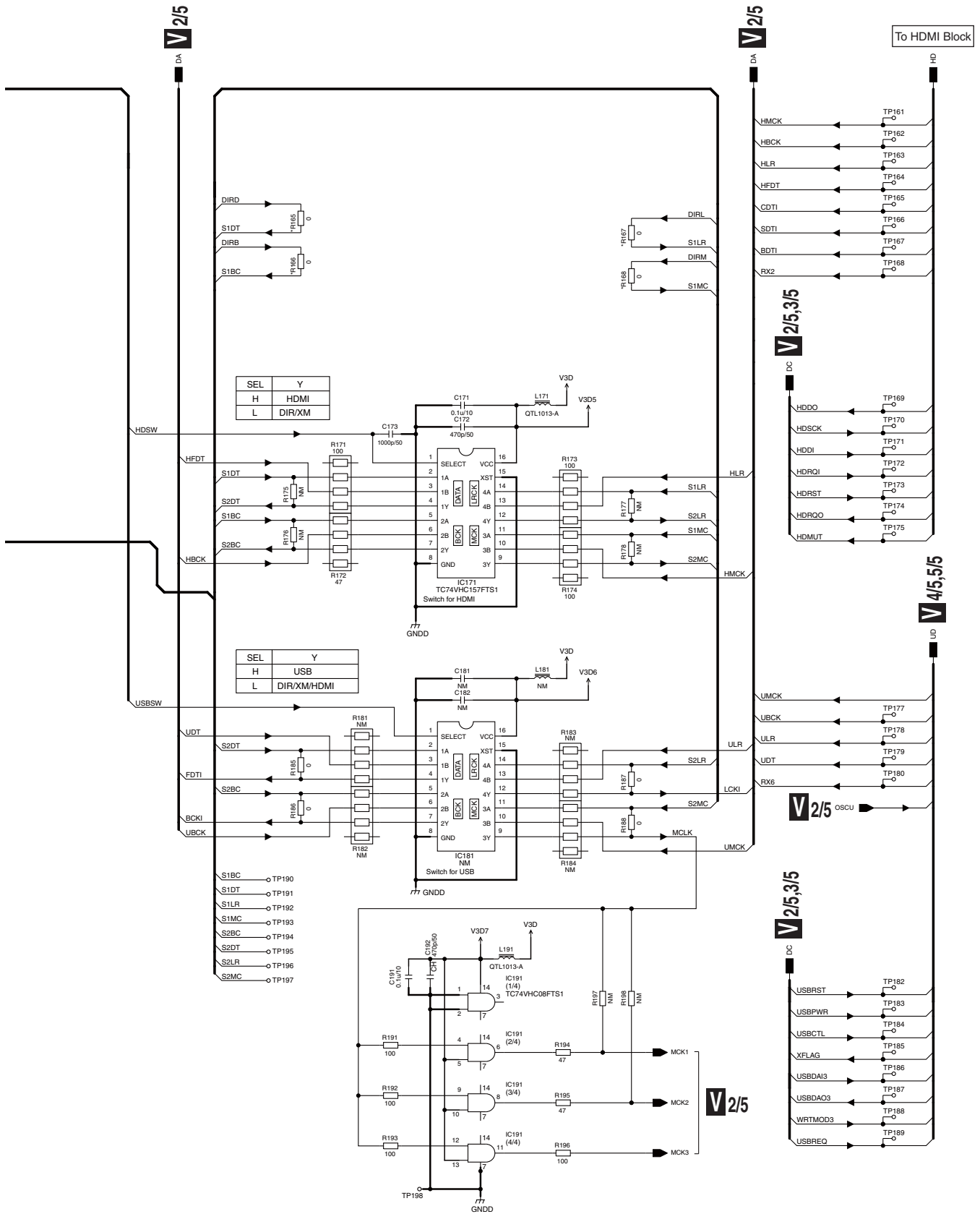

VSX-918V-K

# 10.16 HDMI & DSP & USB ASSY (2/5)

## V 2/5 HDMI & DSP & USB ASSY (VSX-918V:AWX8977)

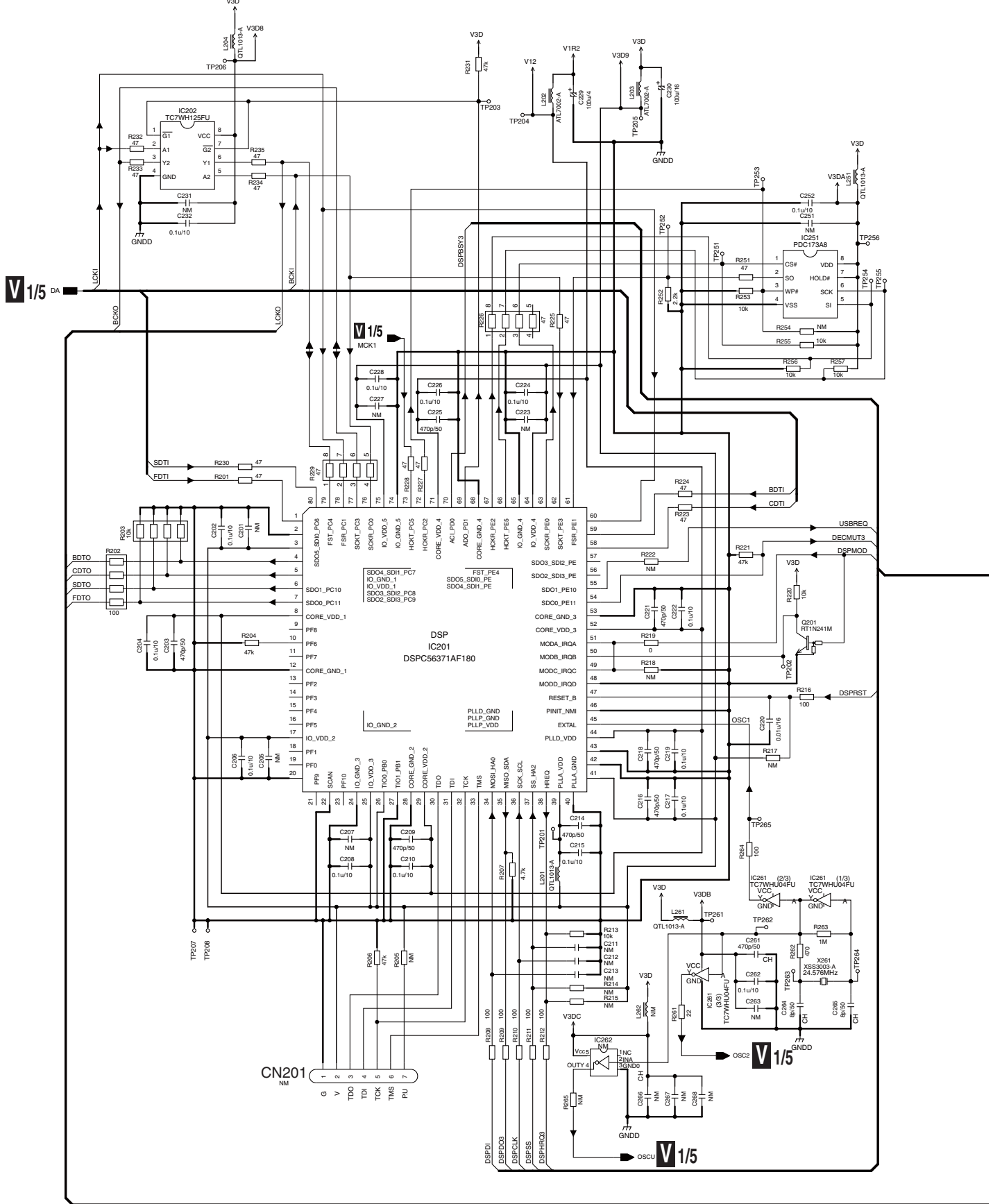

## V 2/5

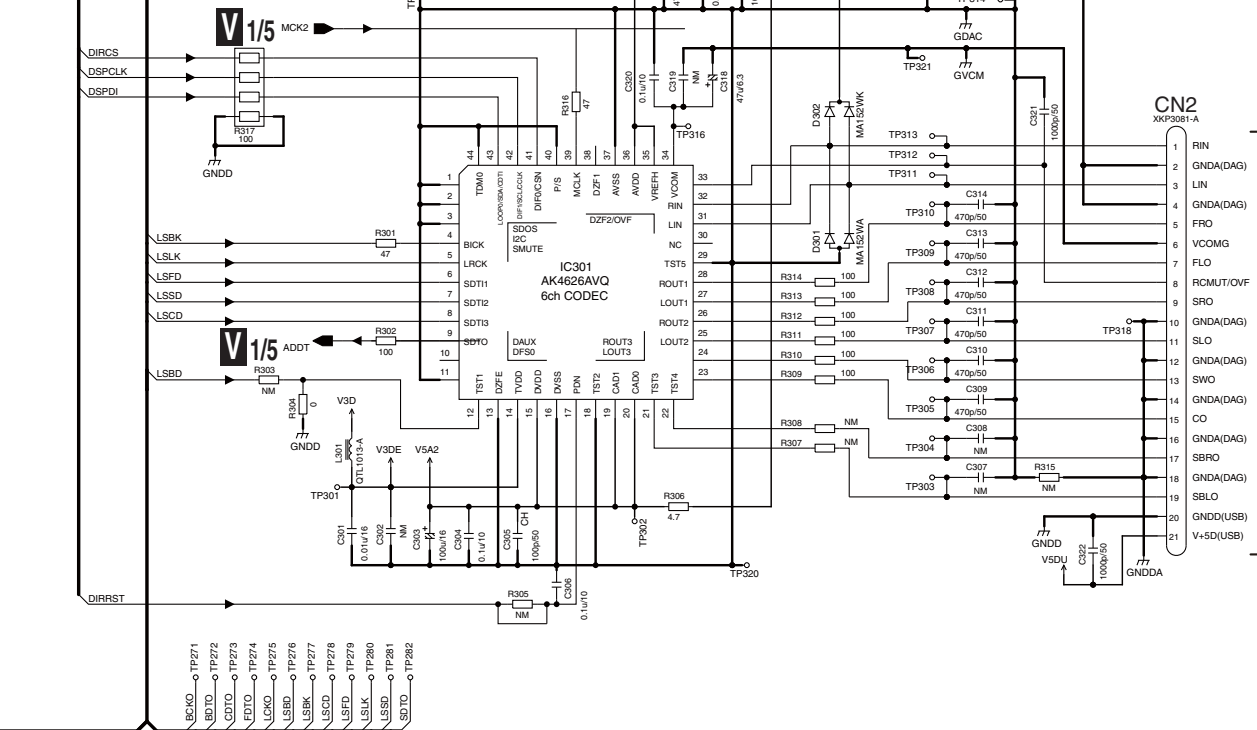
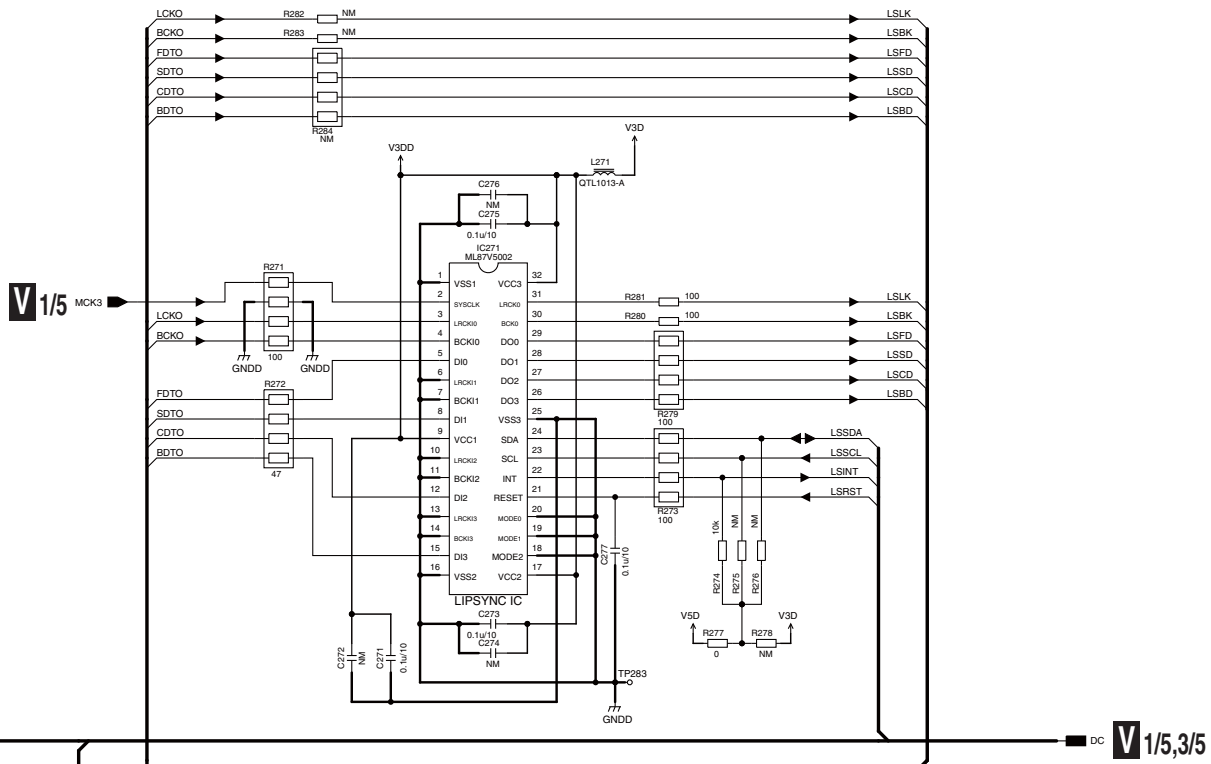

VSX-918V-K

V 2/5



- XMLSDP3 ○ TP347
- XMDO3 ○ TP346
- XMDI3 ○ TP345
- XMRST3 ○ TP344
- XMMUT3 ○ TP343
- XMLNK3 ○ TP342
- XMANT3 ○ TP340
- USBDAO3 ○ TP339
- XMFS3 ○ TP338
- DIRERR3 ○ TP337
- DSPHRQ3 ○ TP336
- DECMUT3 ○ TP335
- DIRDO3 ○ TP334
- DSPBSY3 ○ TP333
- DSPDO3 ○ TP332

- XMDT4 ○ TP14
- XMSCRT ○ TP15
- XMPWR ○ TP16
- XMSW ○ TP17
- XMDI ○ TP18
- XMMUT ○ TP19
- XMFST ○ TP20
- XMANT ○ TP21
- XMDO ○ TP22
- XMLSDP ○ TP23
- XMFS ○ TP24
- XMLNK ○ TP25
- XMERR ○ TP26

DC V 1/5,2/5

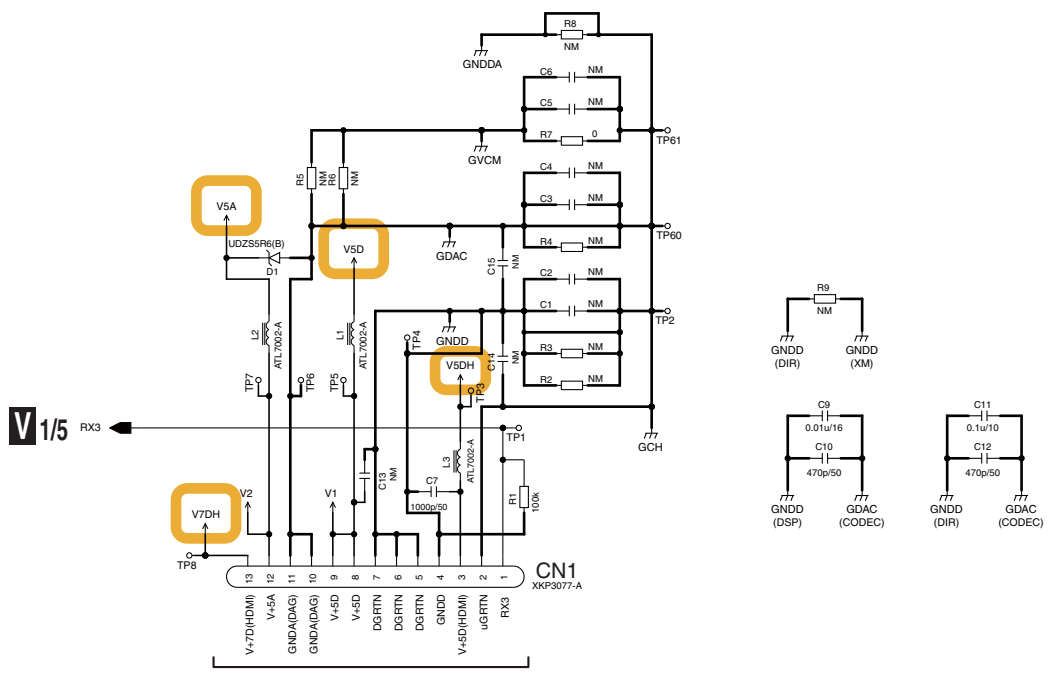
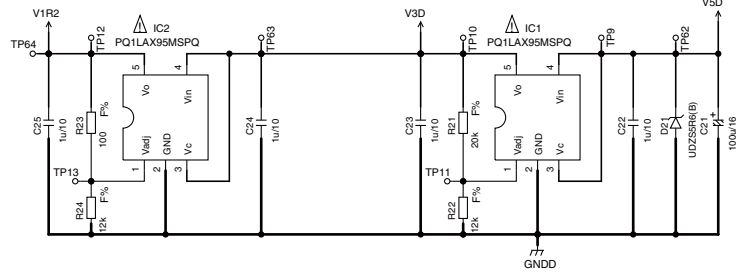

C 2/2 CN805

VSX-918V-K

V 3/5

# 10.18 HDMI & DSP & USB ASSY (4/5)

## V 4/5 HDMI & DSP & USB ASSY (VSX-918V:AWX8977)

A  
B  
C  
D  
E  
F

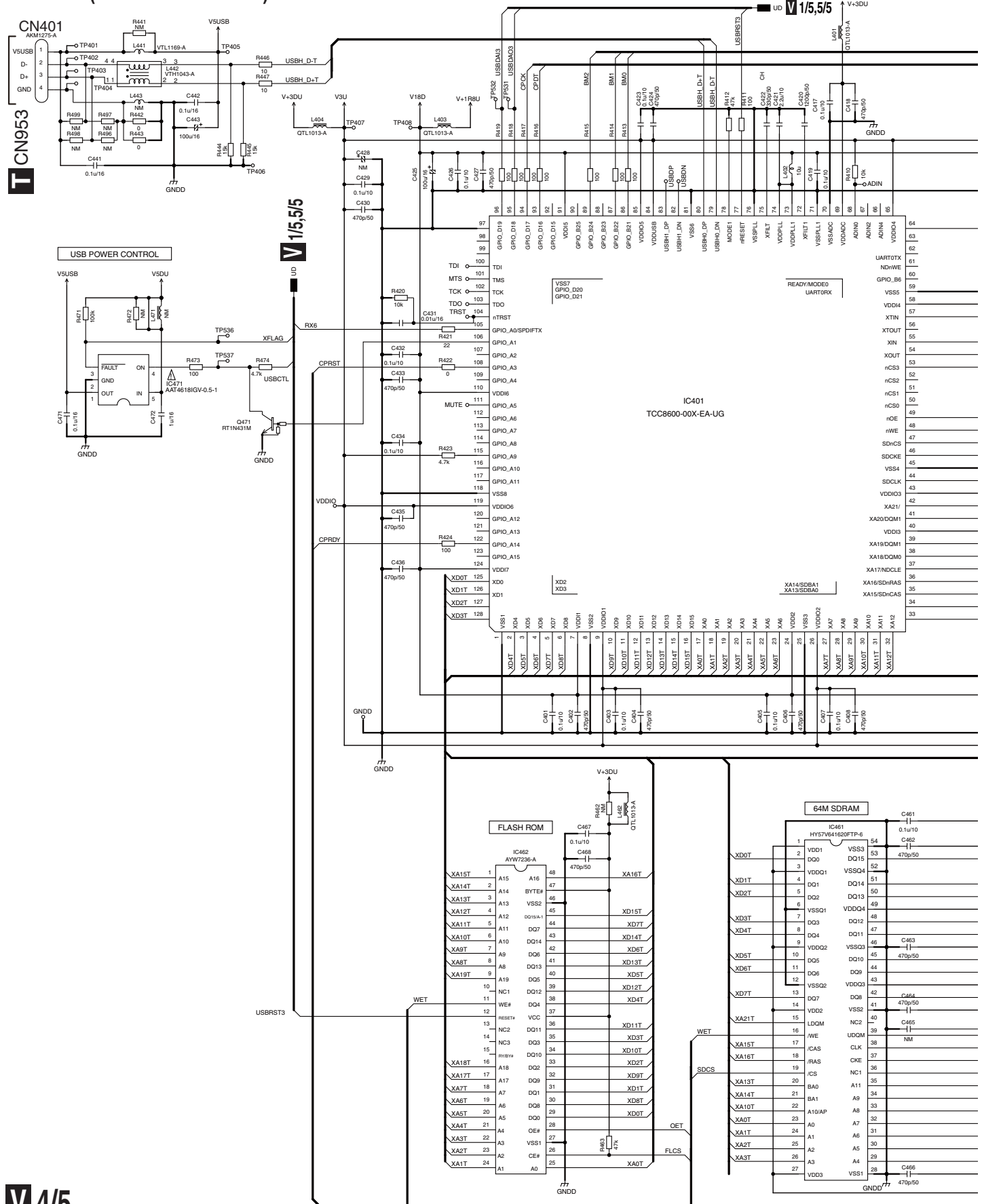

## V 4/5

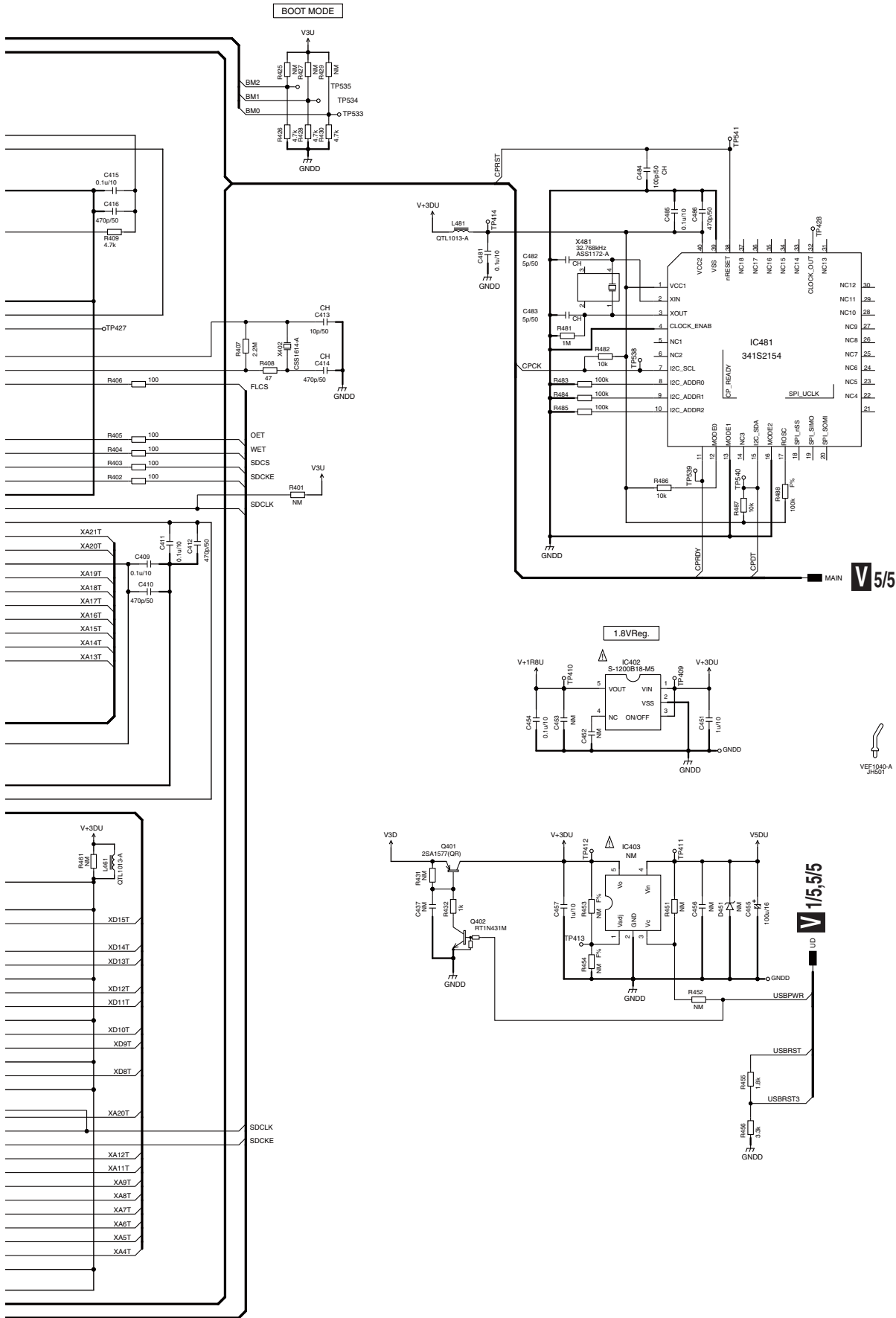

VSX-918V-K

# 10.19 HDMI & DSP & USB ASSY (5/5)

## V 5/5 HDMI & DSP & USB ASSY (VSX-918V:AWX8977)

CN501

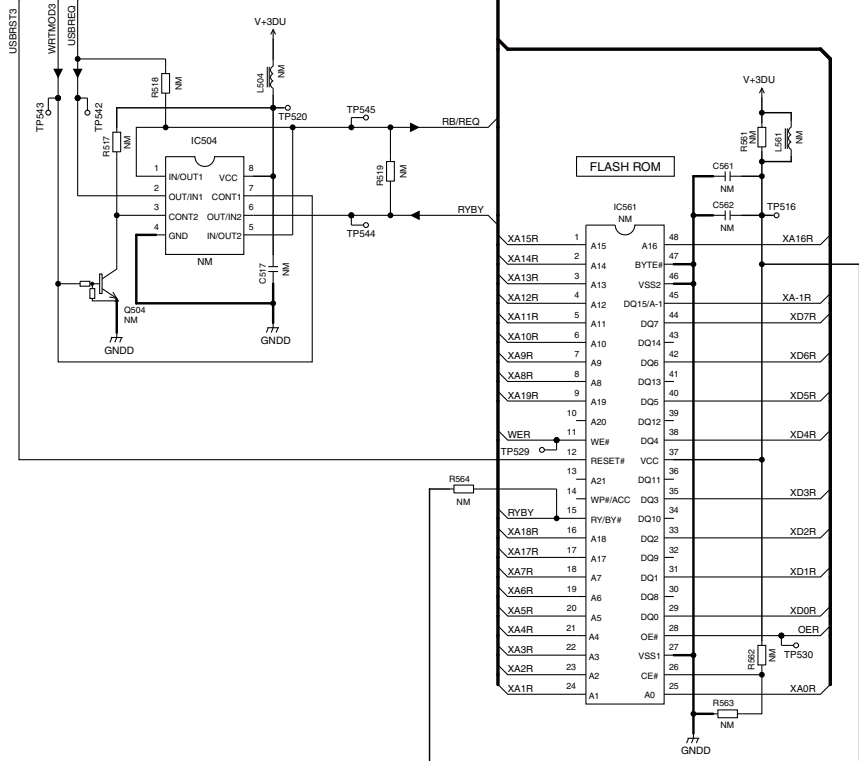
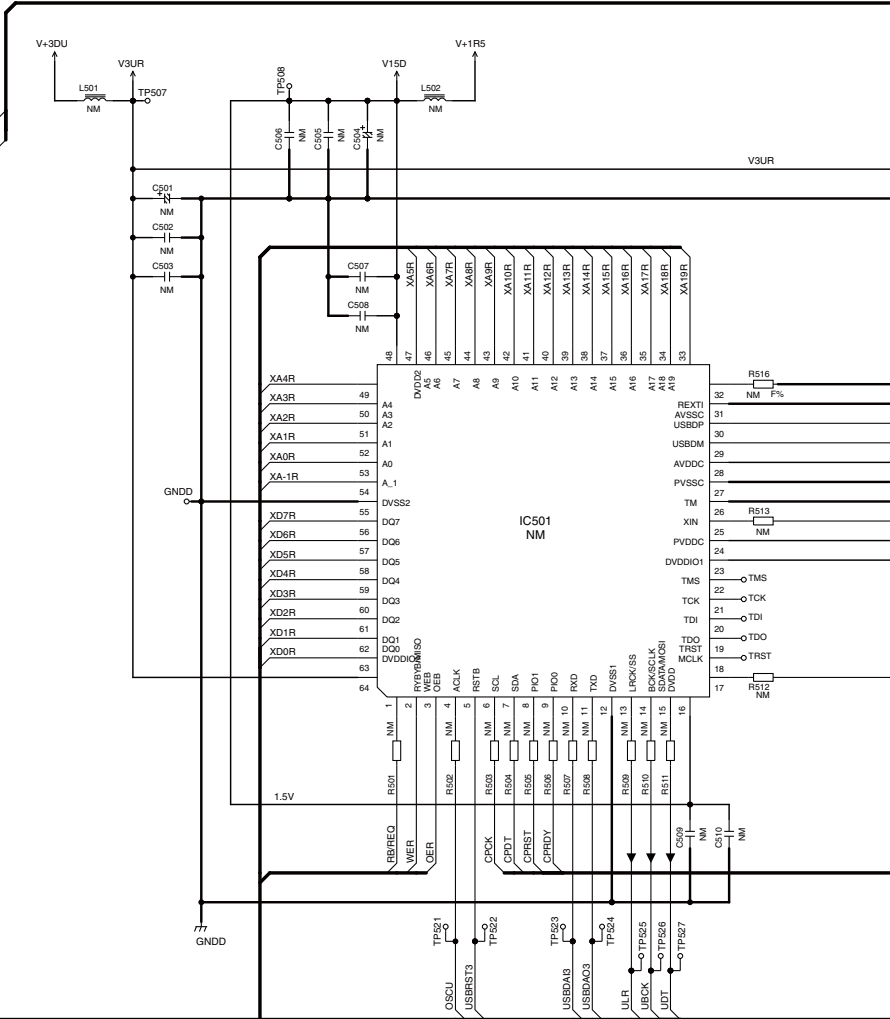
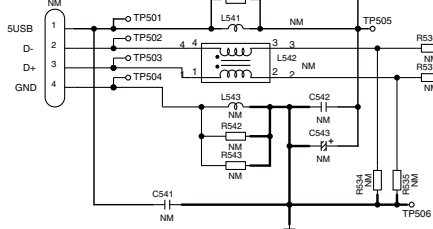

V 5/5

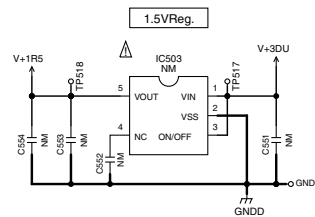
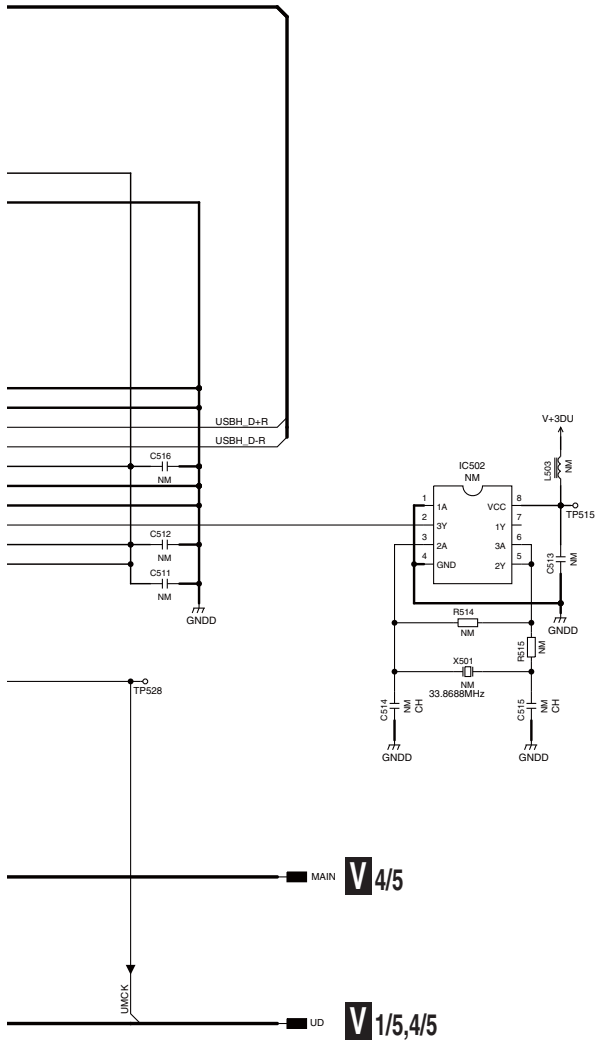

# 11. PCB CONNECTION DIAGRAM

## 11.1 DSP & USB and HDMI ASSYS

### SIDE A

#### NOTE FOR PCB DIAGRAMS :

1. Part numbers in PCB diagrams match those in the schematic diagrams.
2. A comparison between the main parts of PCB and schematic diagrams is shown below.
3. The parts mounted on this PCB include all necessary parts for several destinations.  
For further information for respective destinations, be sure to check with the schematic diagram.
4. View point of PCB diagrams.

Symbol In PCB Diagrams	Symbol In Schematic Diagrams	Part Name
		Transistor
		Transistor with resistor
		Field effect transistor
		Resistor array
		3-terminal regulator

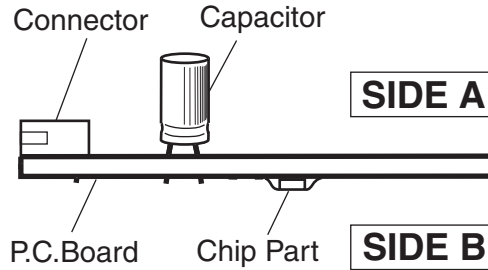

### B DSP&USB ASSY

#### T CN953

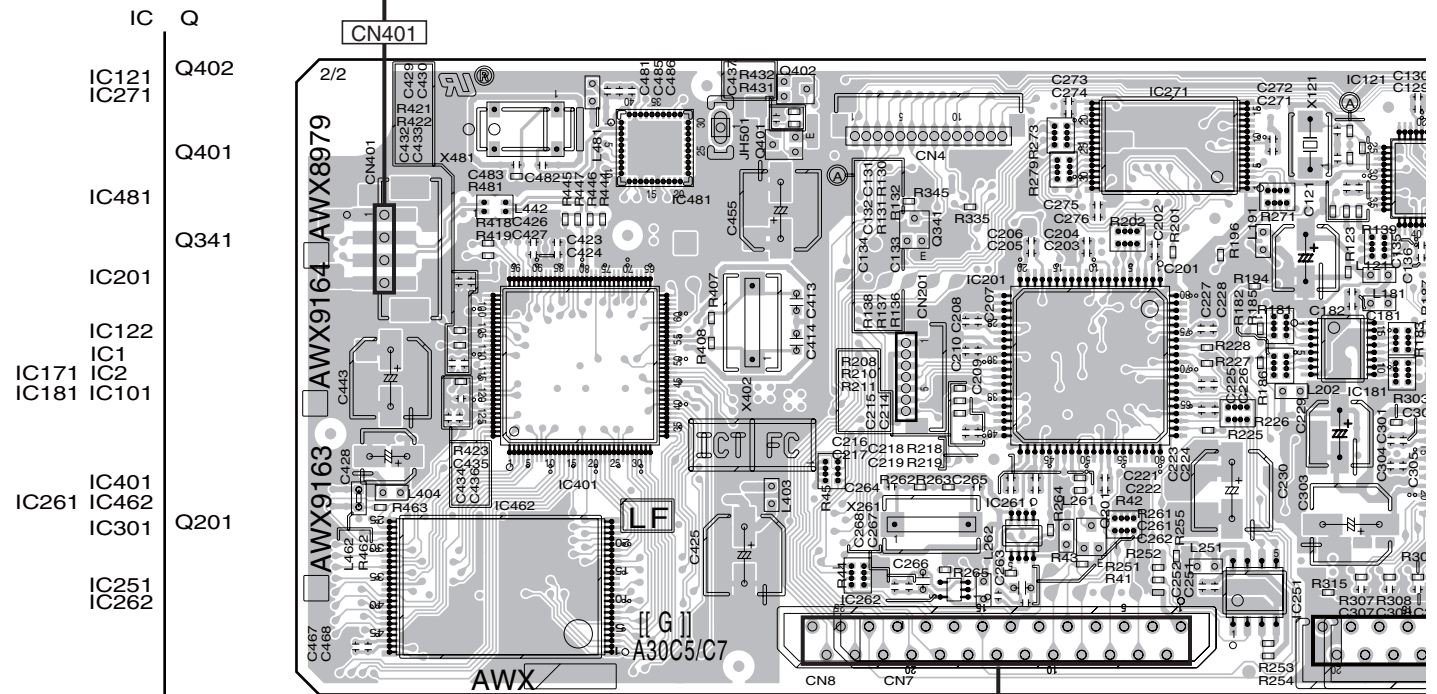

#### A CN112

#### C

### B

SIDE A

# W HDMI ASSY

- IC Q
- Q153
- Q151
- Q154
- Q152
- Q121
- Q101
- IC103
- IC101
- IC102
- Q123
- Q122
- IC901
- IC911

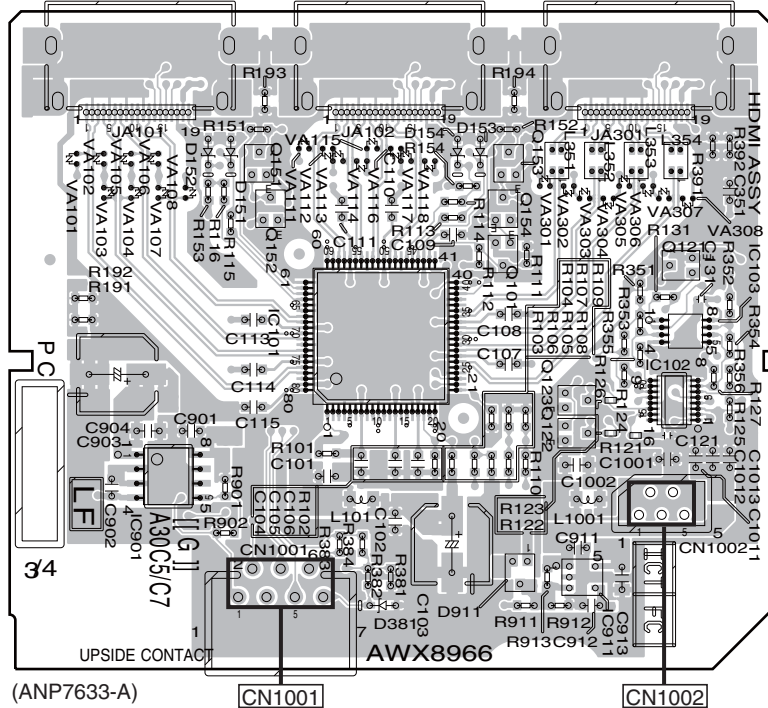

(ANP7633-A)

CN1001

CN1002

**A** CN104

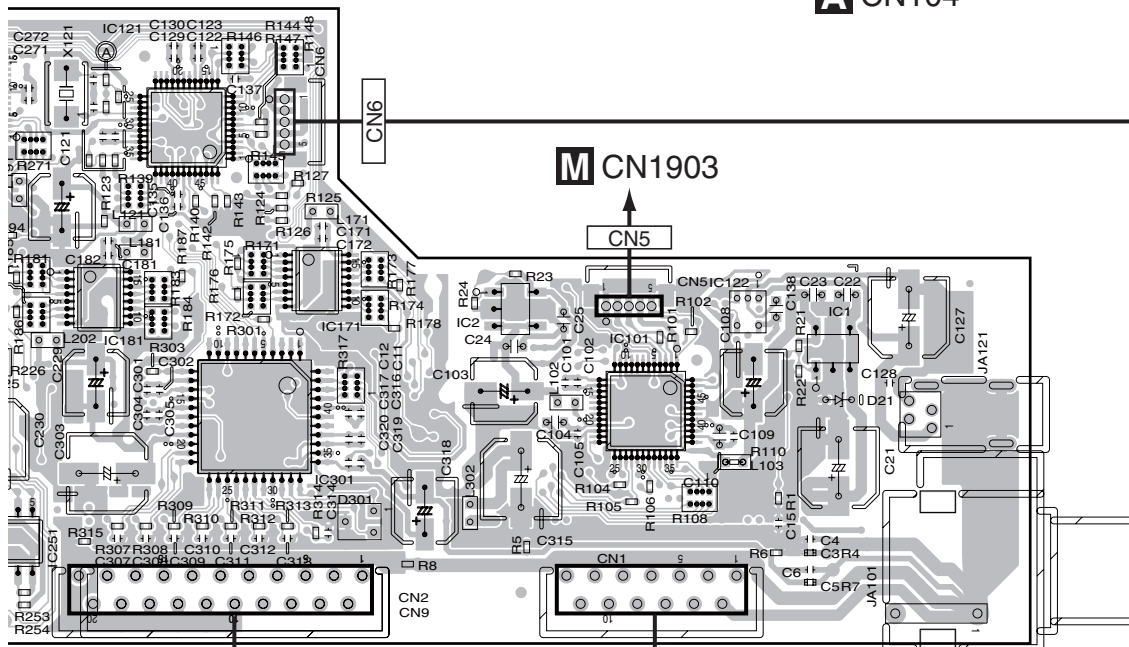

**M** CN193

CN5

**C** CN805

**C** CN806

(ANP7635-A)

VSX-918V-K

**B** **W**

**SIDE B**

A

**W HDMI ASSY**

B

C

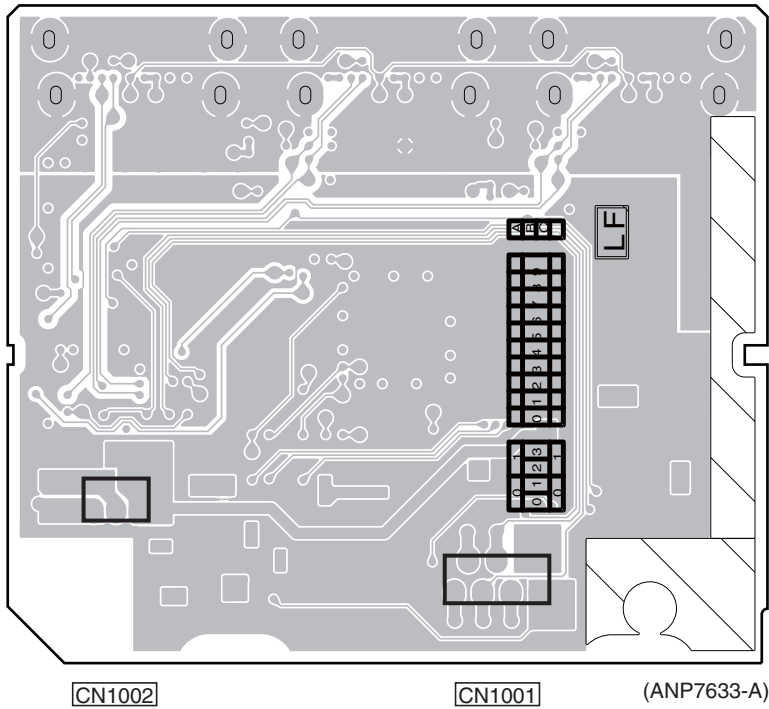

D

E

F

- IC Q
- IC331
- IC402
- IC341
- IC202
- IC403
- IC191
- IC351
- Q471
- IC471
- IC161
- IC461

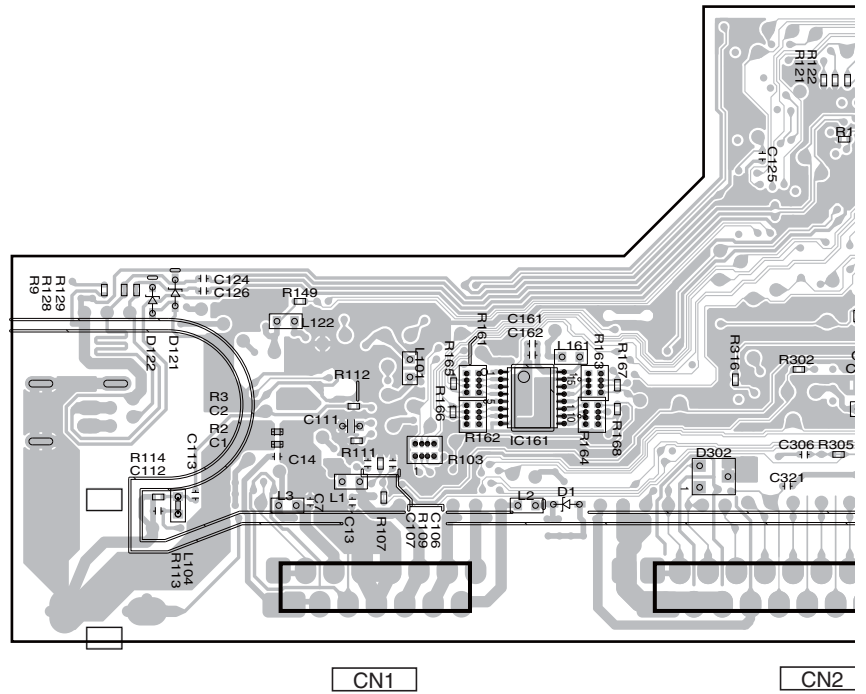

SIDE B

A  
B  
C  
D  
E  
F

**B** DSP&USB ASSY

CN401

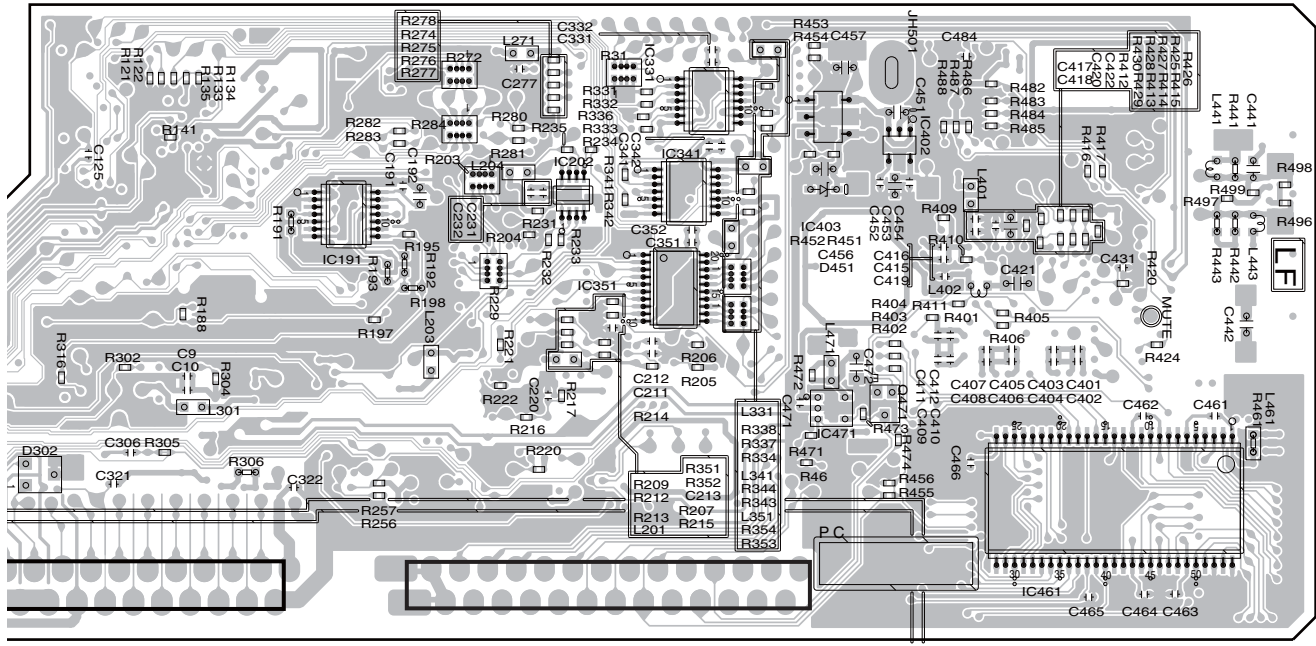

CN2

CN8

(ANP7635-A)

VSX-918V-K

**B**

# 11.2 MAIN ASSY

**SIDE A**

A

B

C

D

E

F

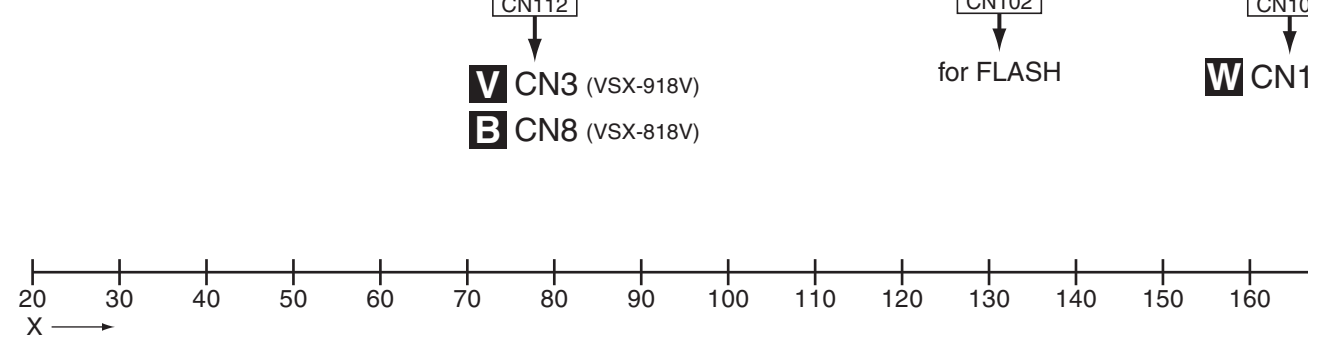
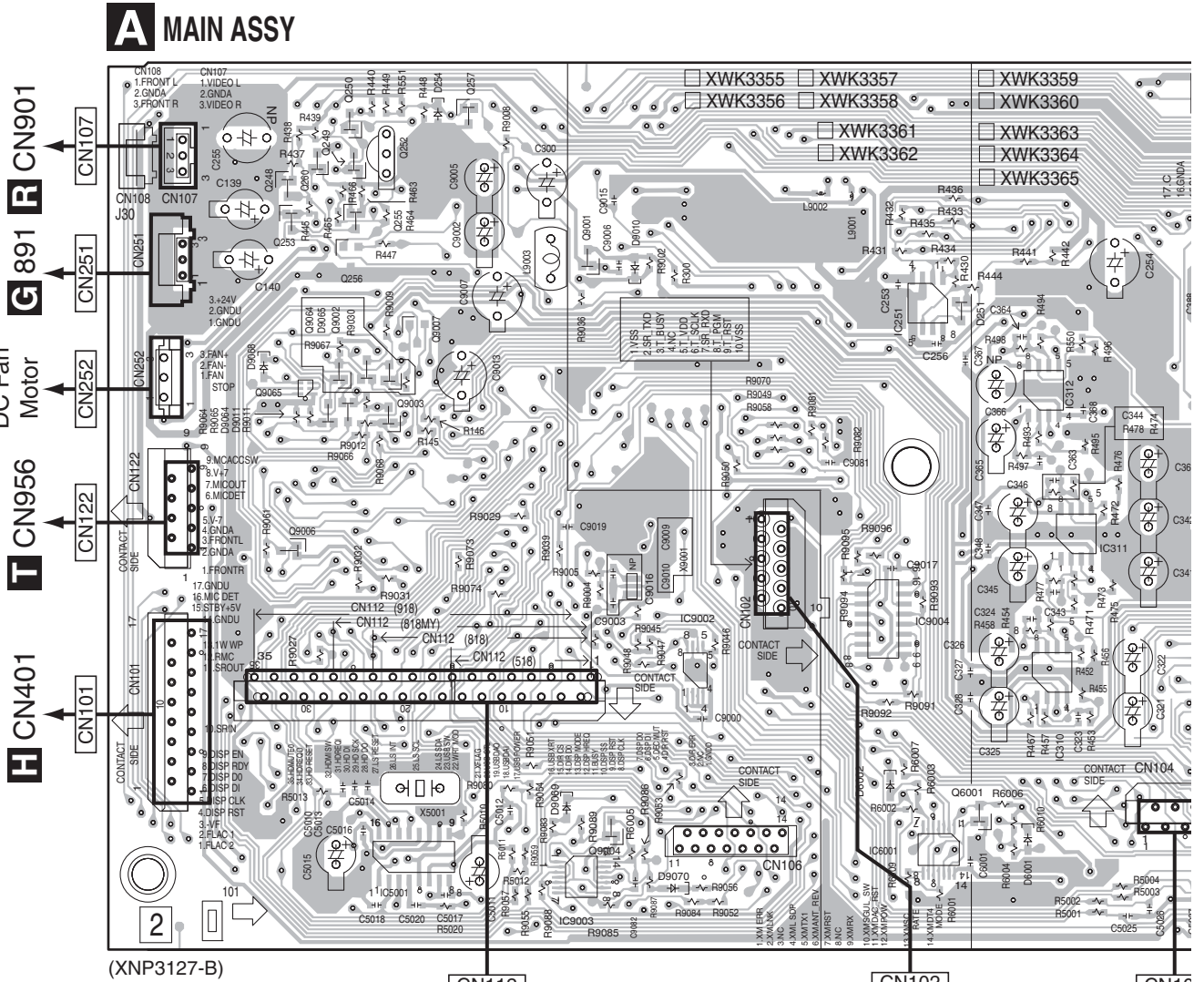
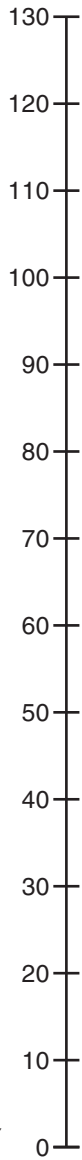

**A**



SIDE B

A

B

C

D

E

F

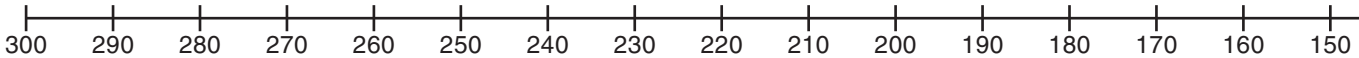
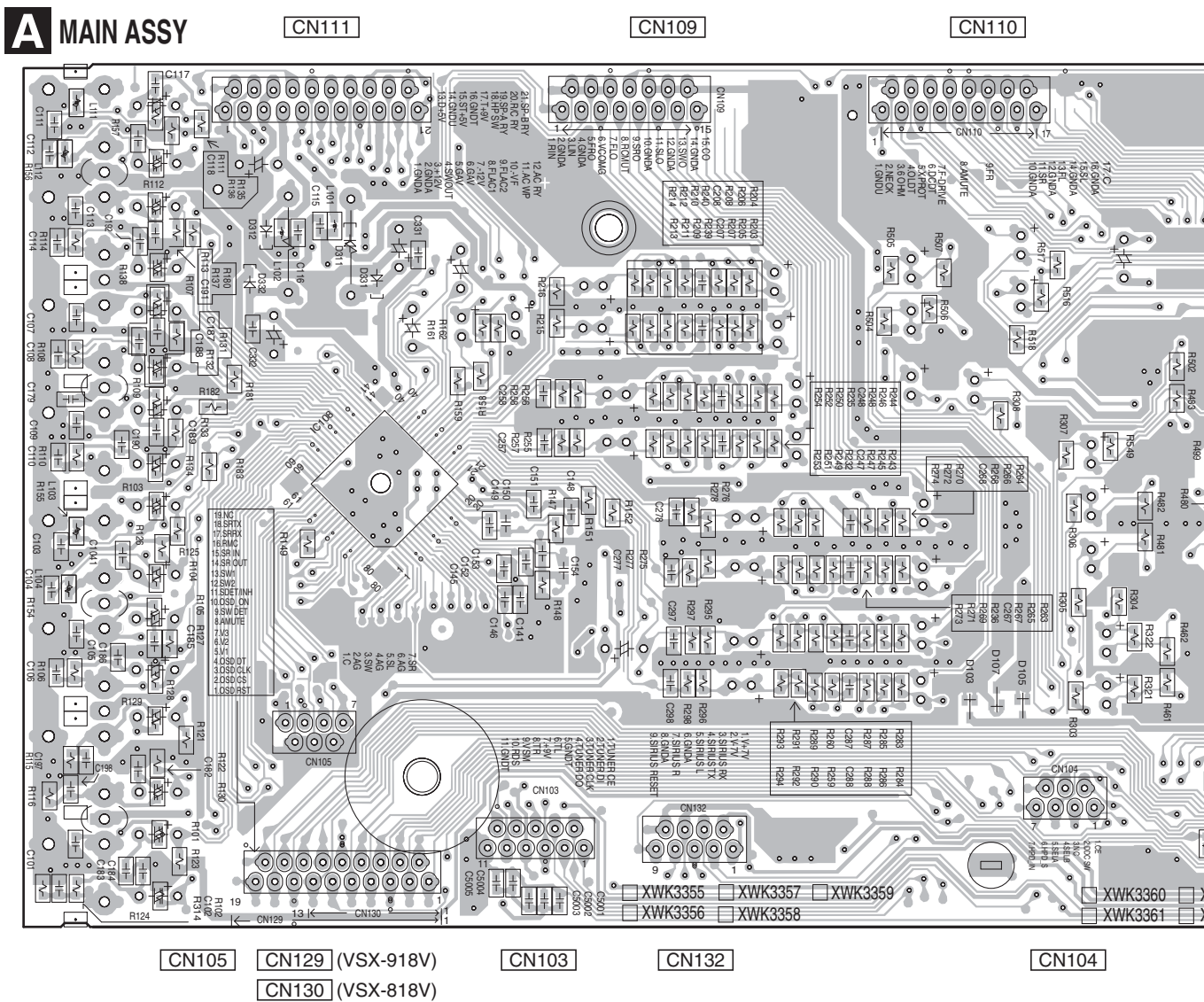

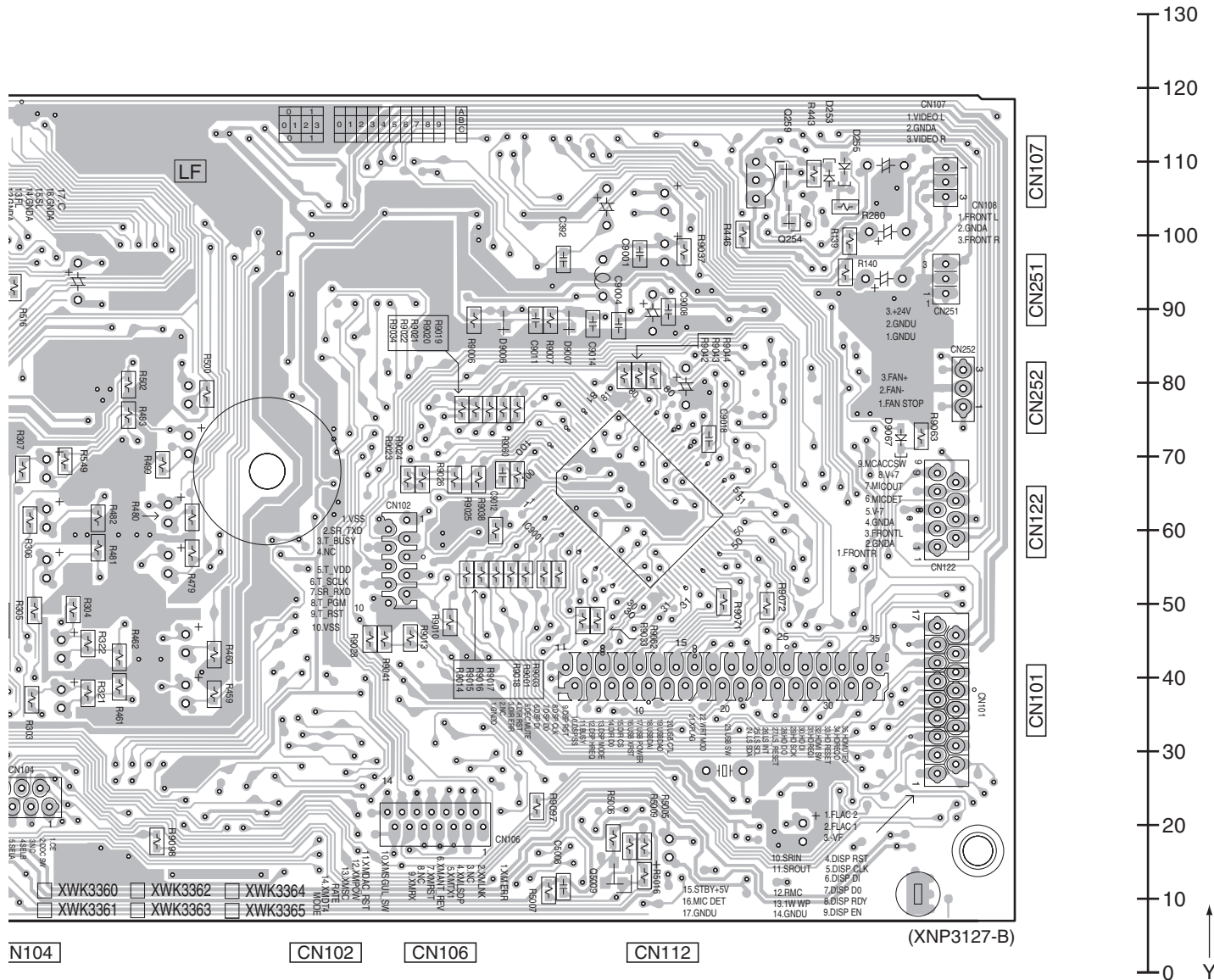

# 11.3 POWER PACK ASSY

SIDE A

POWER PACK ASSY

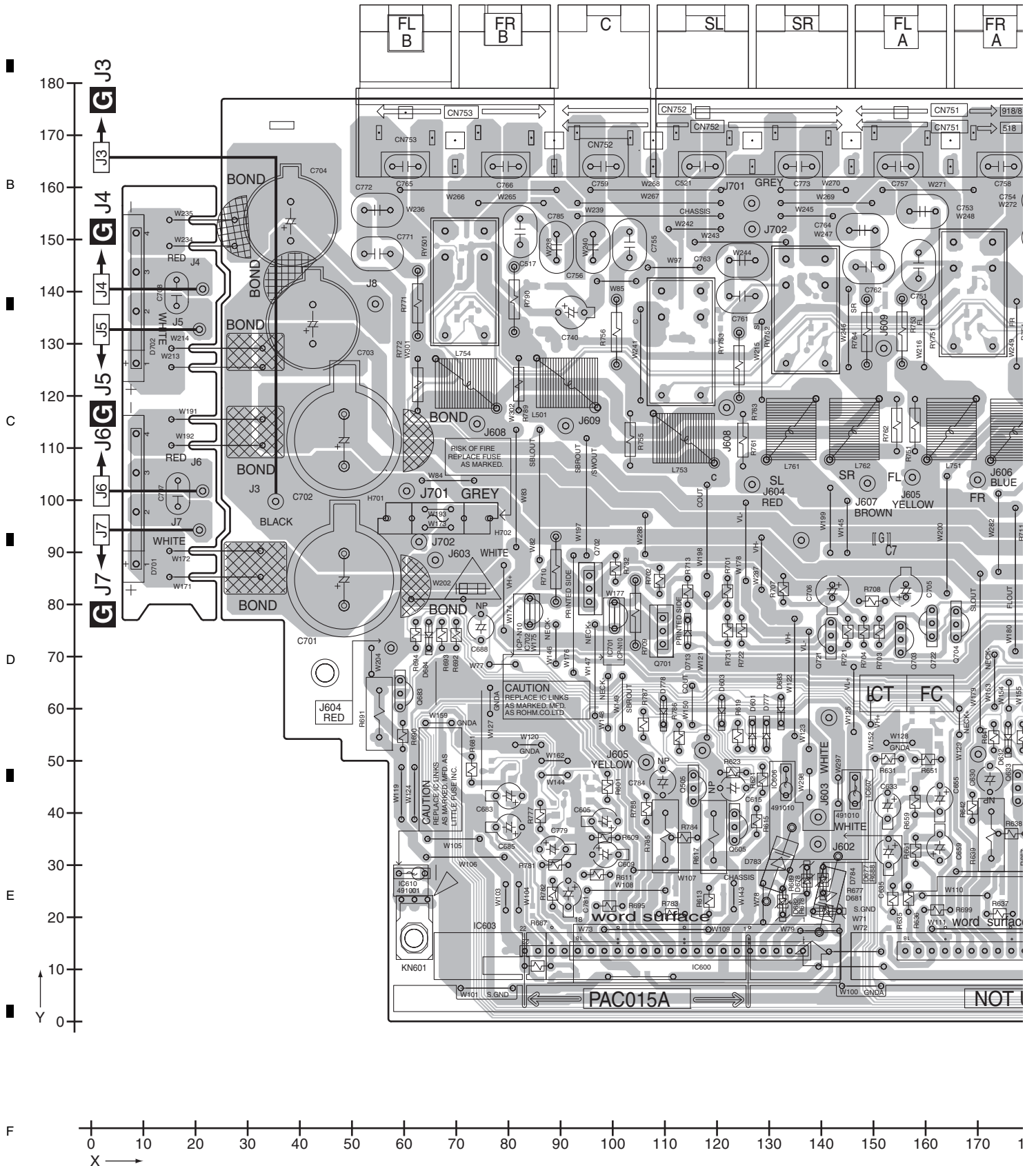



SIDE B

POWER PACK ASSY

CN805 CN816 810 CN803 CN701 CN702

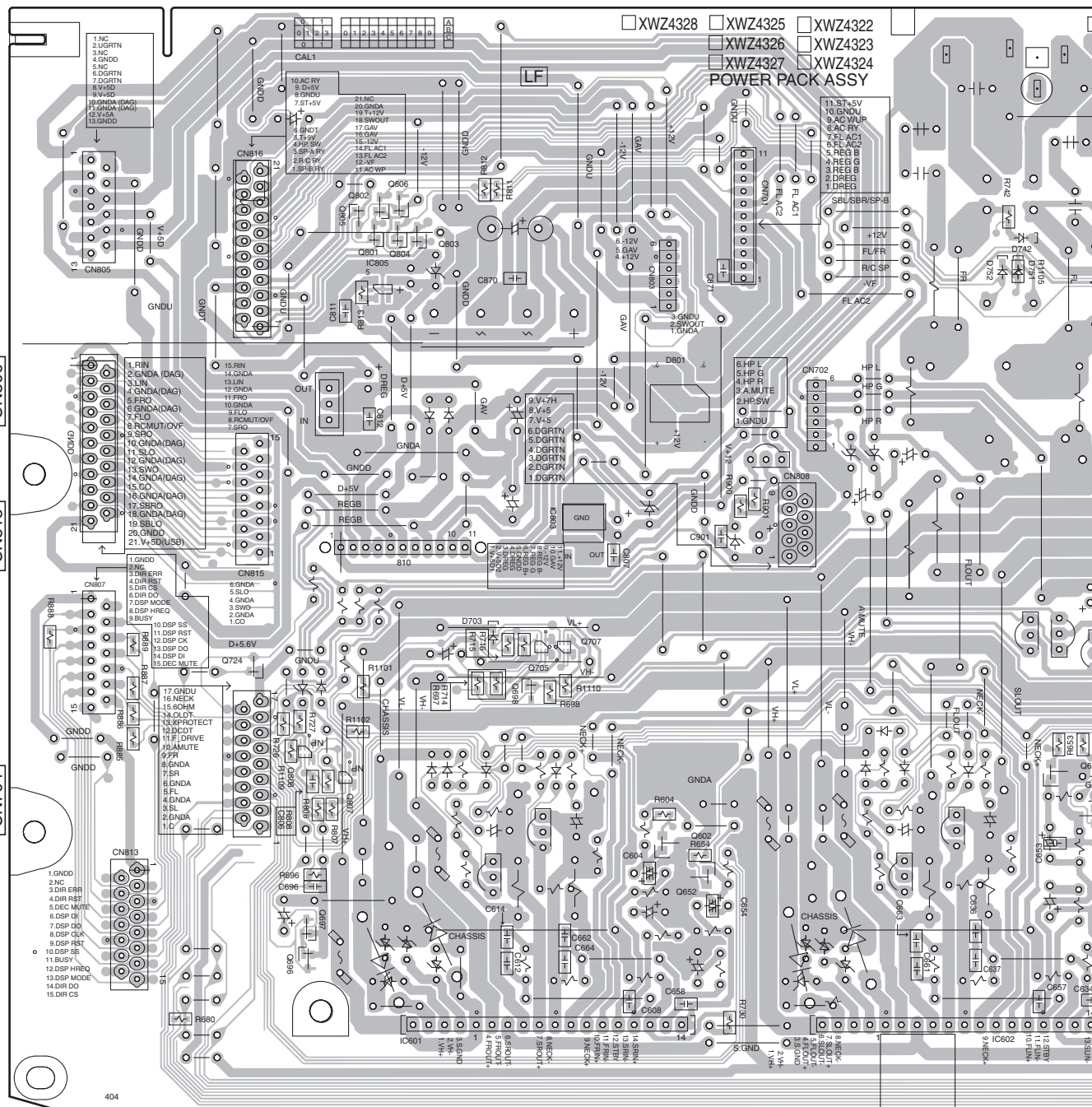

330 320 310 300 290 280 270 260 250 240 230 220 210 200 190 180 170 160

C



# 11.4 TRANS2 and TRANS3 ASSYS

**SIDE A**

## **D** TRANS2 ASSY

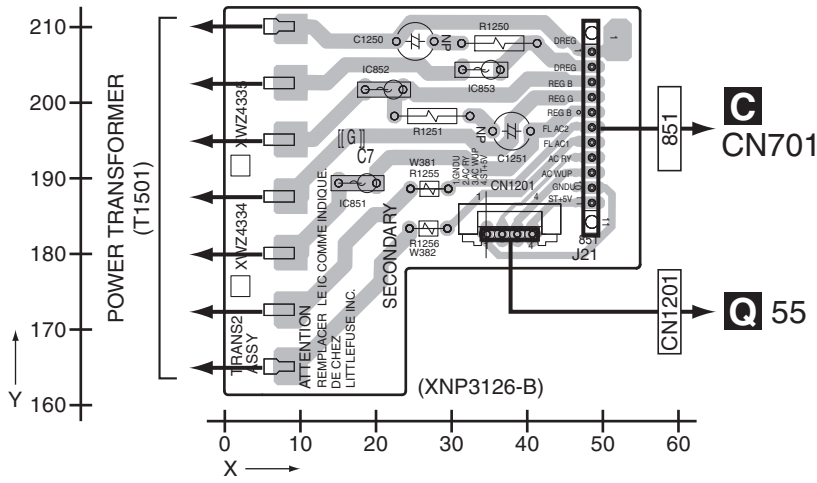

**SIDE B**

## **D** TRANS2 ASSY

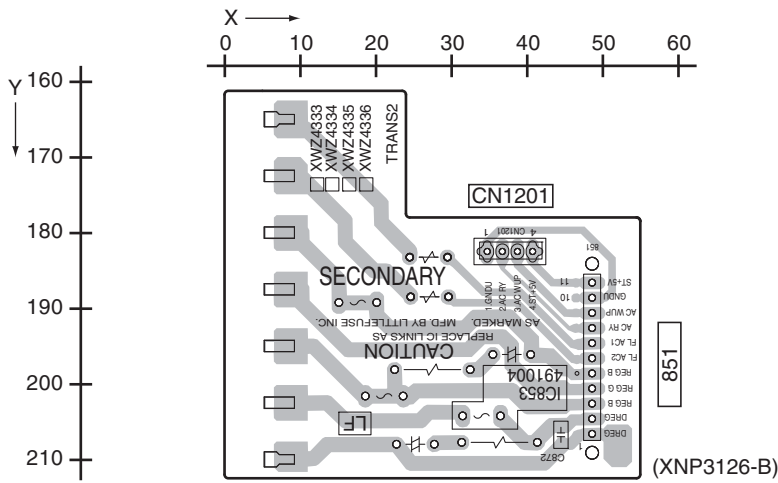

**D**

SIDE A

# G TRANS3 ASSY

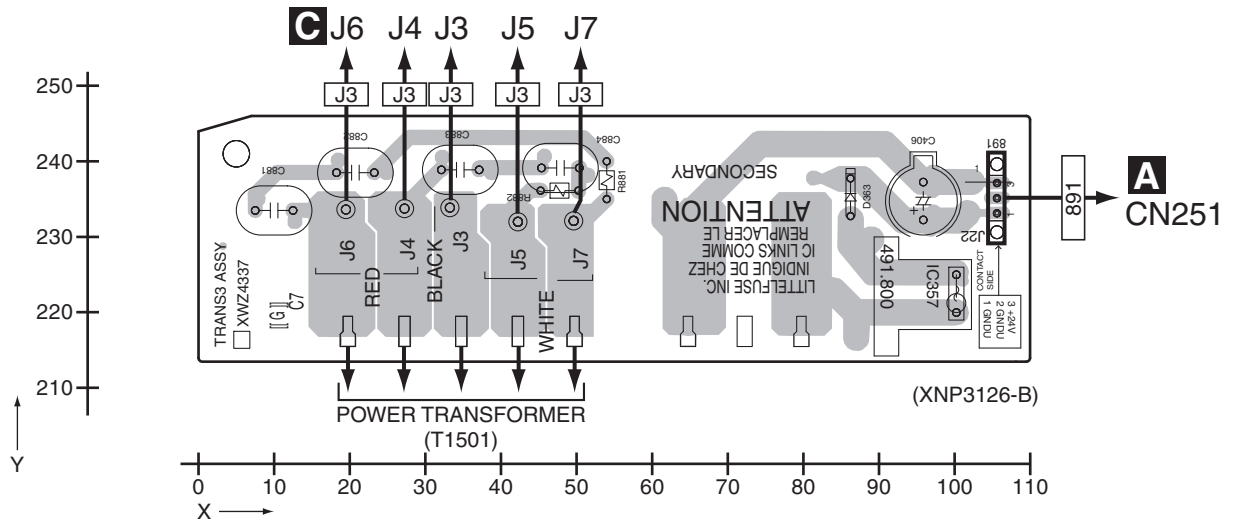

SIDE B

# G TRANS3 ASSY

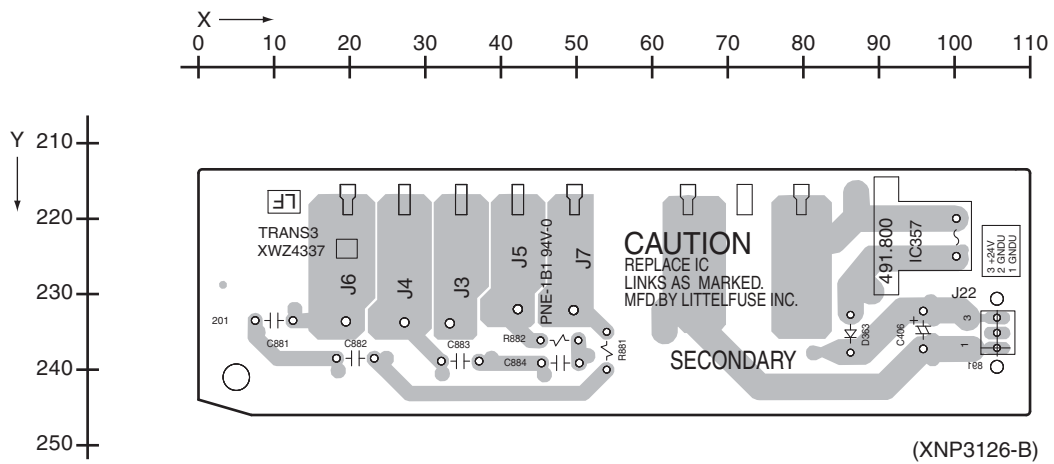







**SIDE A**

# K JOG ASSY

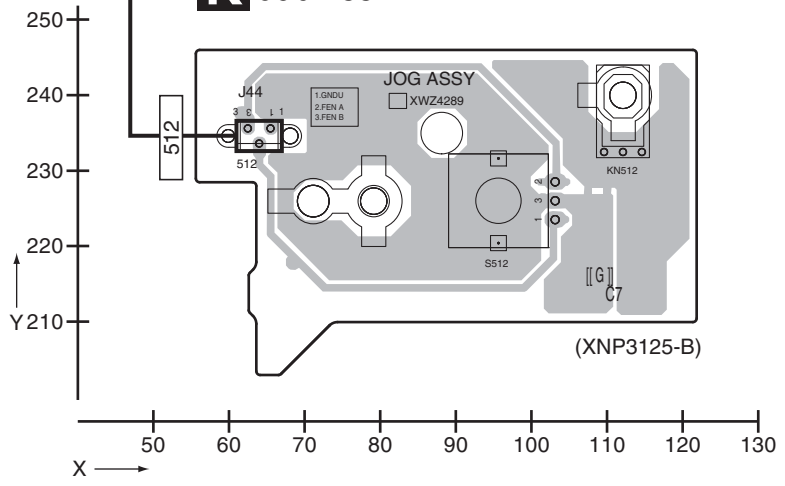

# A CN101

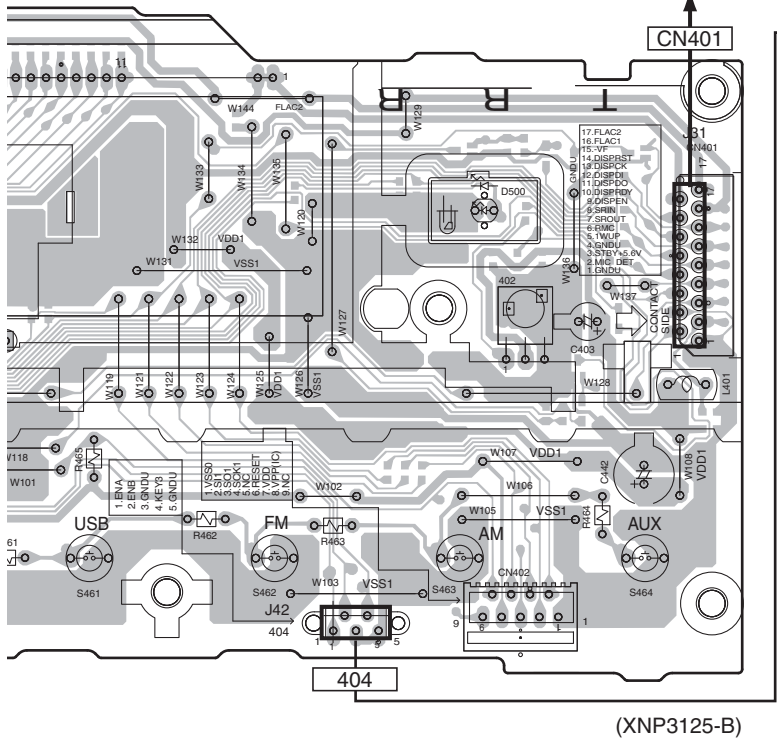

# I ROTARY ENCODER ASSY

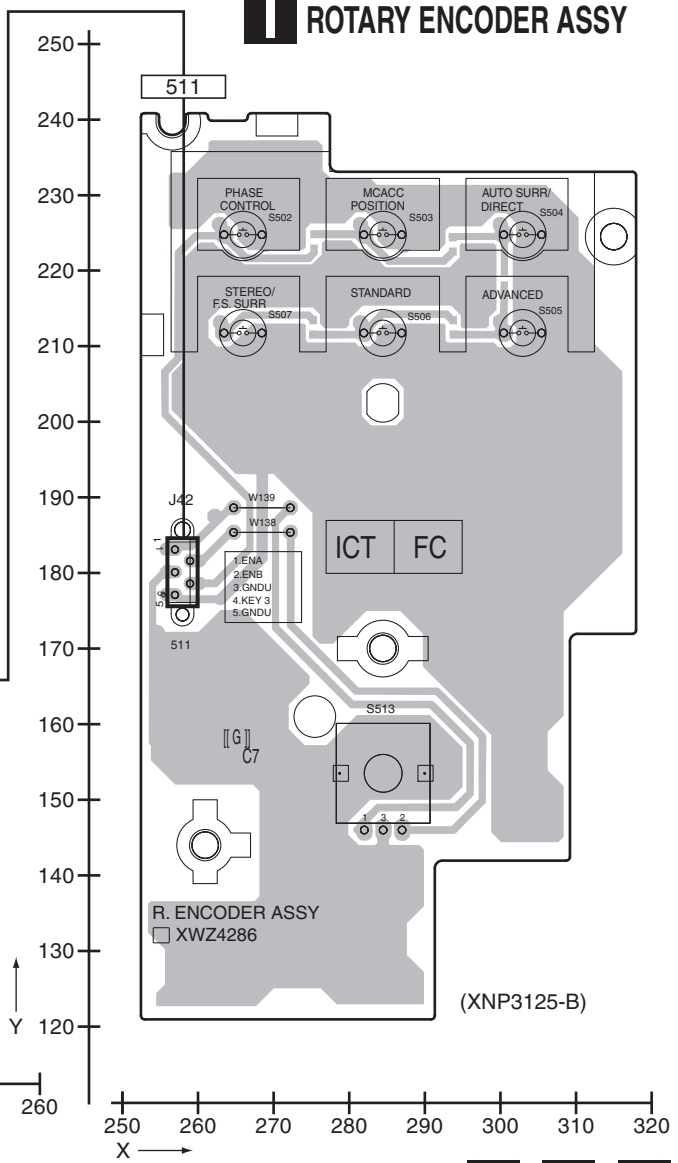

# HIK



**SIDE B**

**J POWER KEY ASSY**

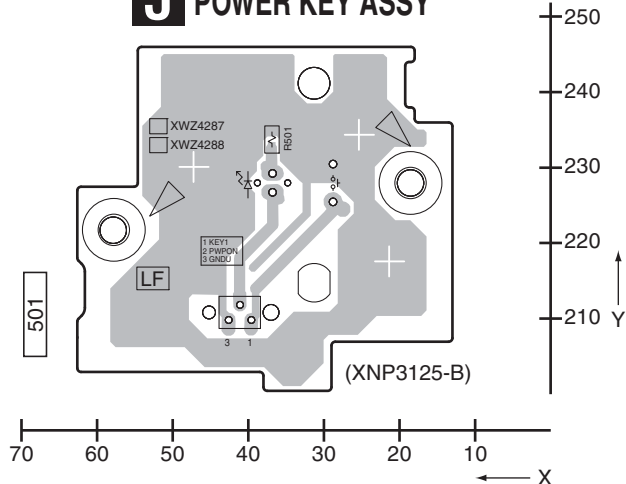

A  
B

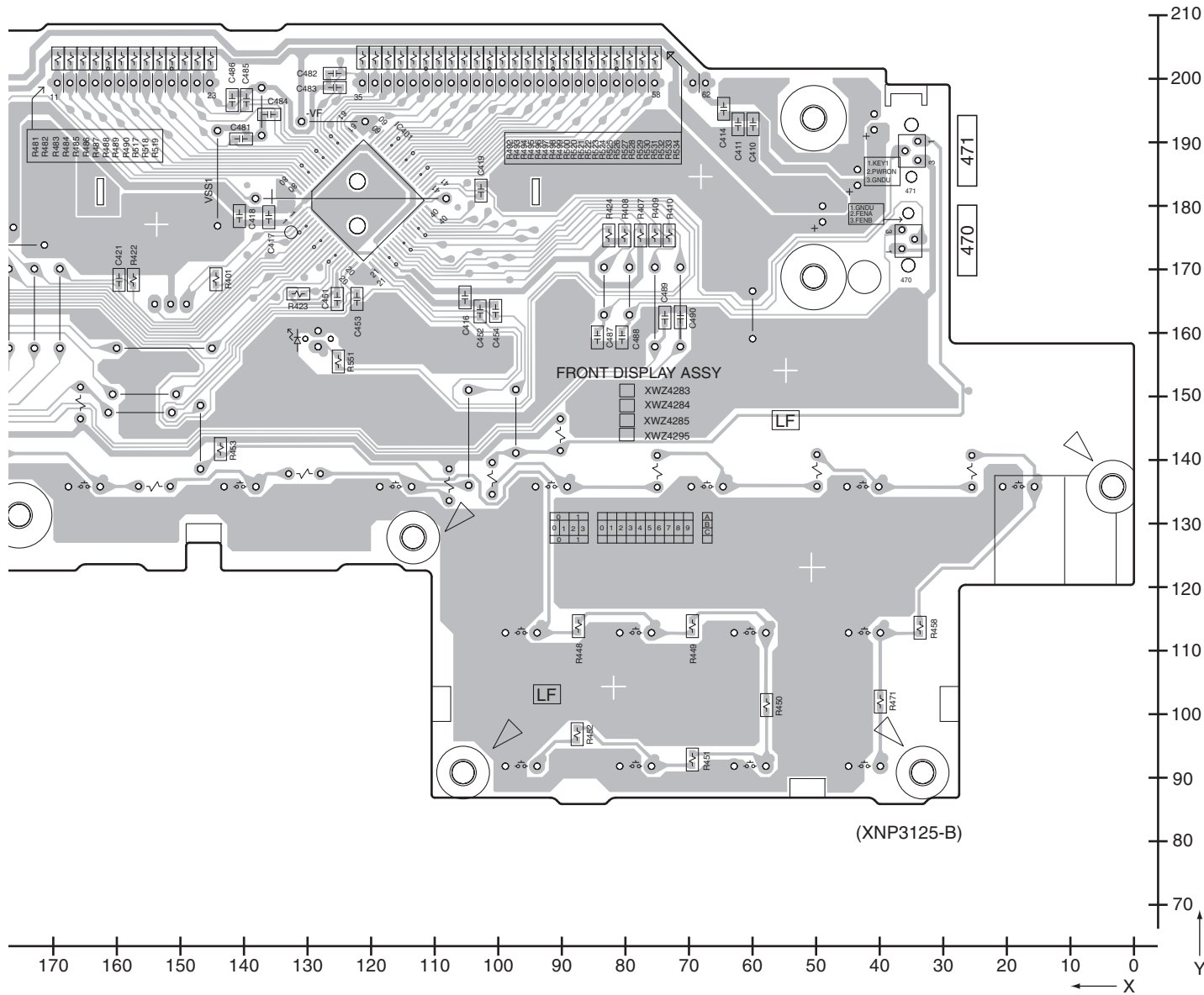

C  
D  
E  
F

# 11.8 DIGITAL INPUT and FRONT VIDEO ASSYS

1 2 3 4

**SIDE A**

**SIDE A**

## M DIGITAL INPUT ASSY

## R FRONT VIDEO ASSY

**V** CN5 (VSX-918V) **B** CN5 (VSX-818V)

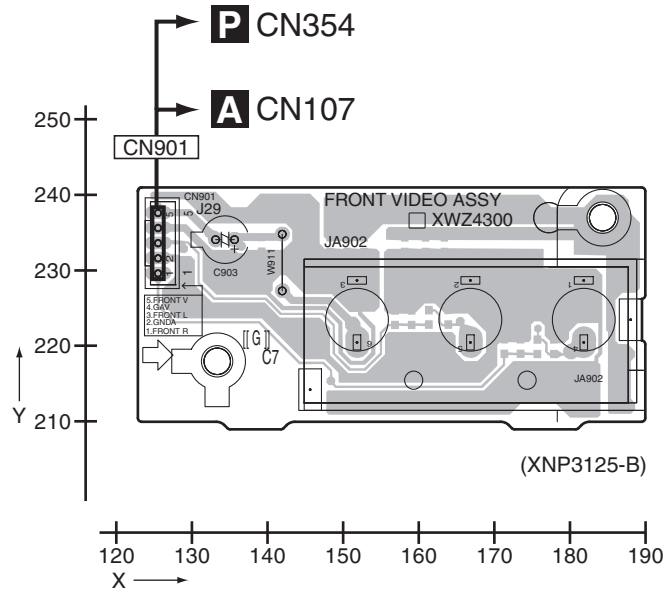
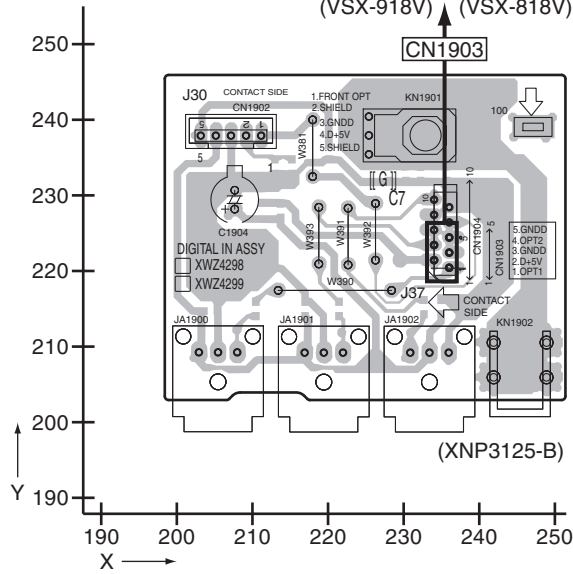

**SIDE B**

**SIDE B**

## M DIGITAL INPUT ASSY

## R FRONT VIDEO ASSY

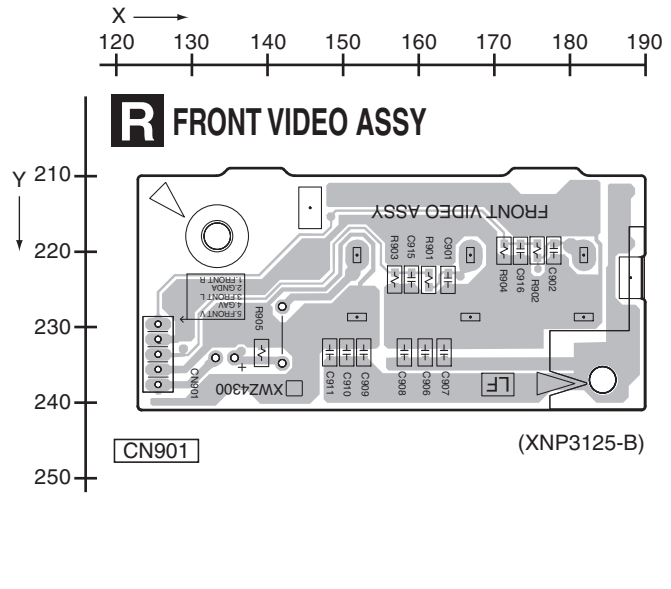
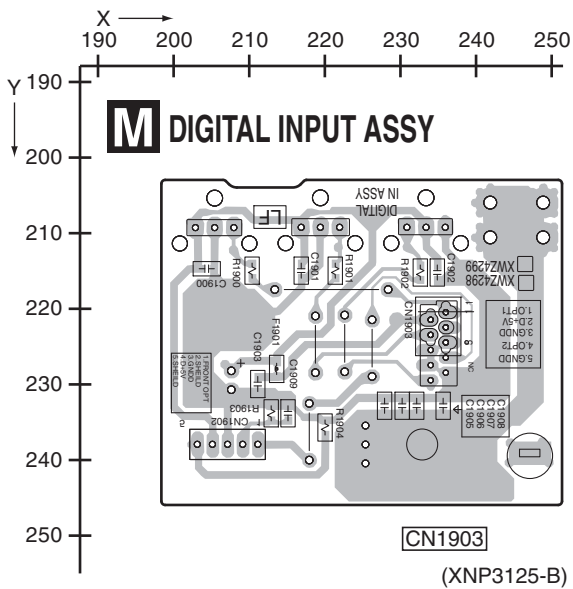

**M R**

**M R**

1 2 3 4

# 11.9 REGULATOR ASSY

SIDE A

SIDE A

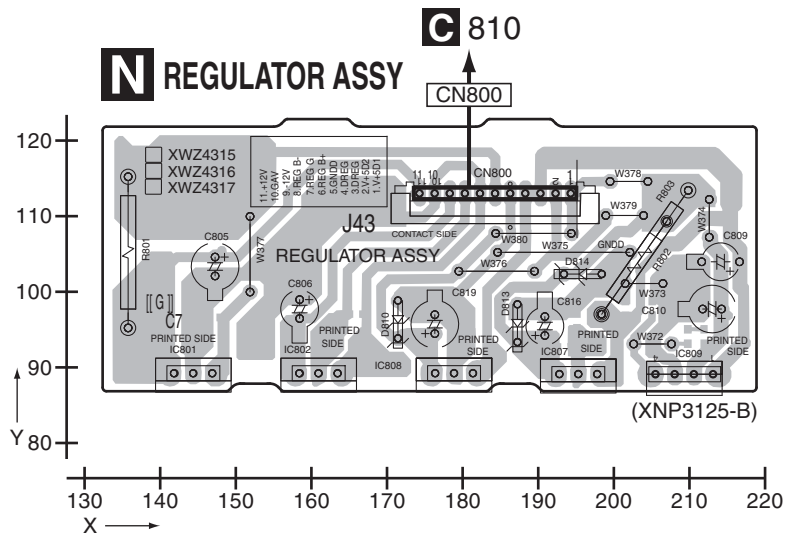

SIDE B

SIDE B

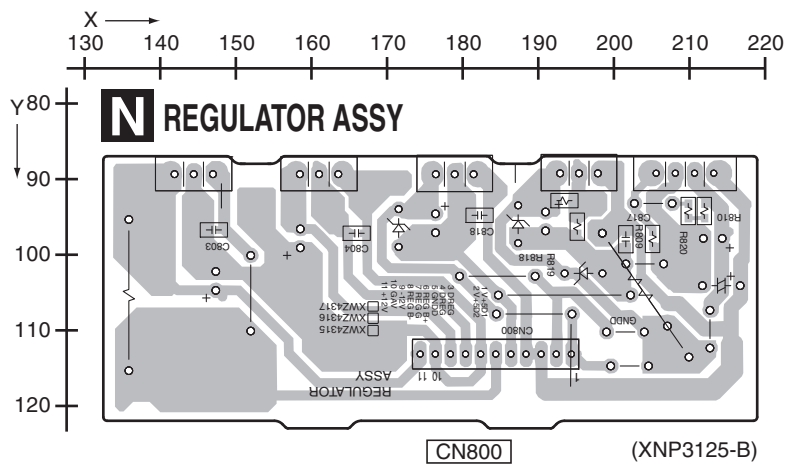

N

N

# 11.10 VIDEO ASSY

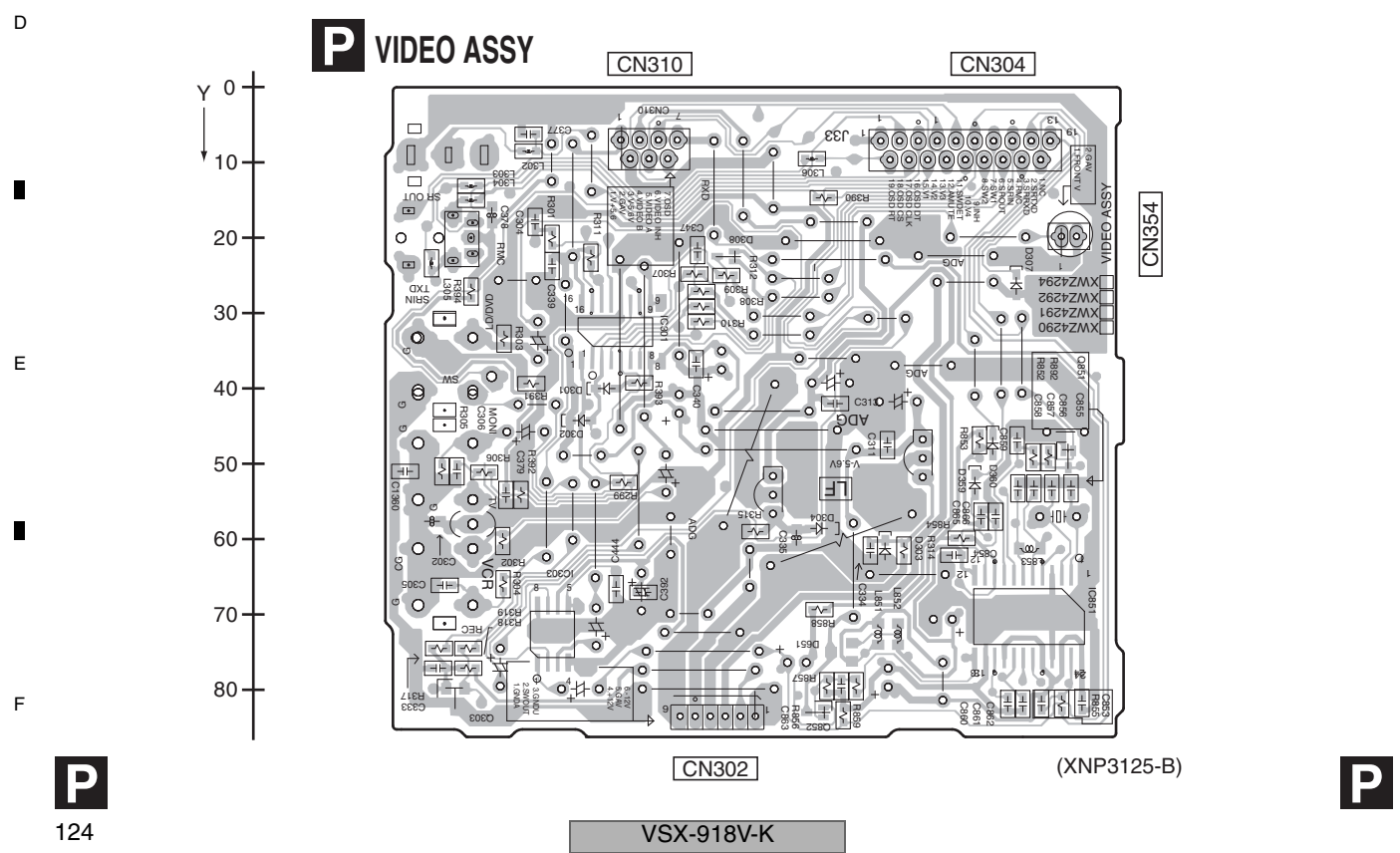
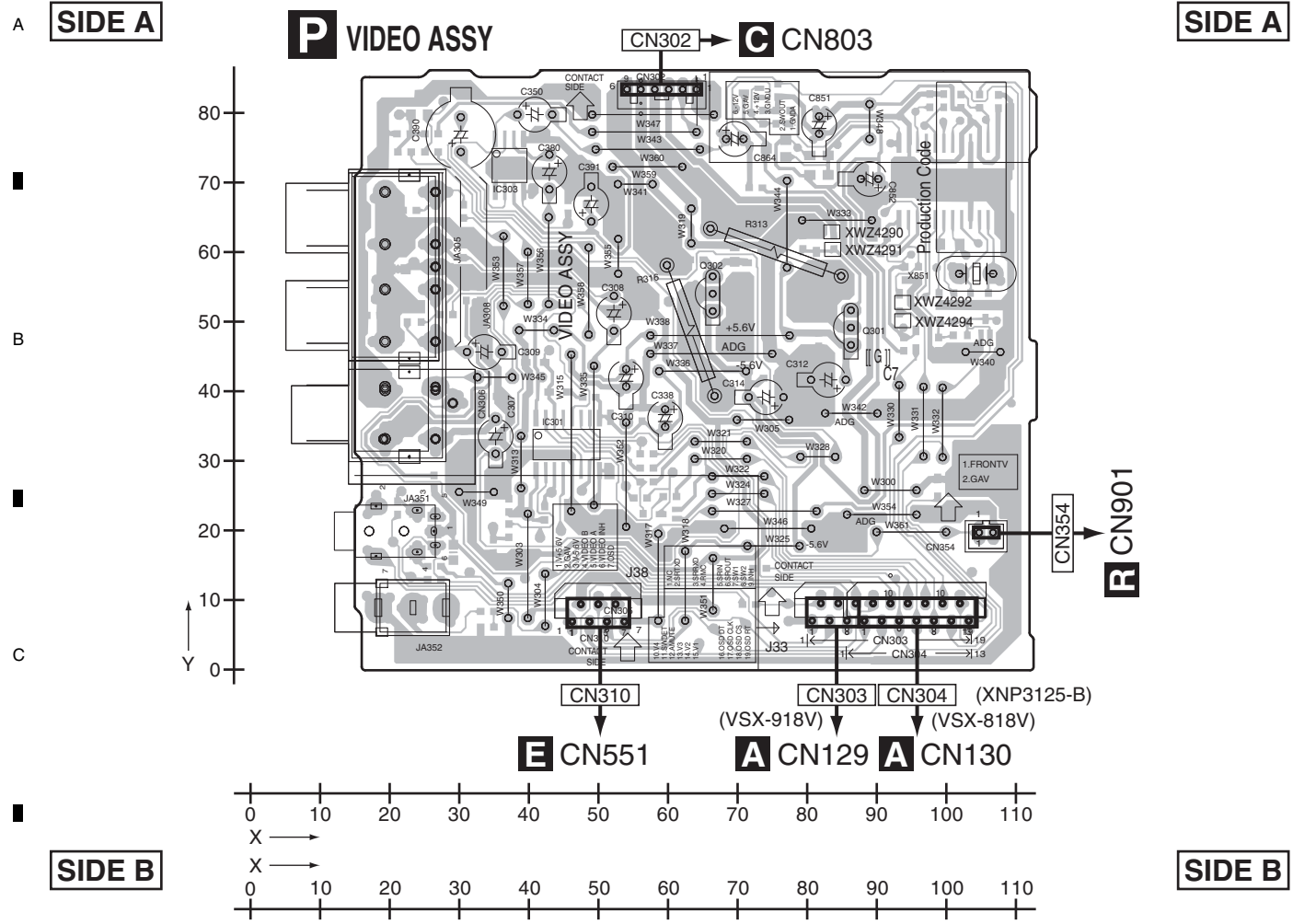

# 11.11 FRONT IN ASSY

**SIDE A**

**SIDE B**

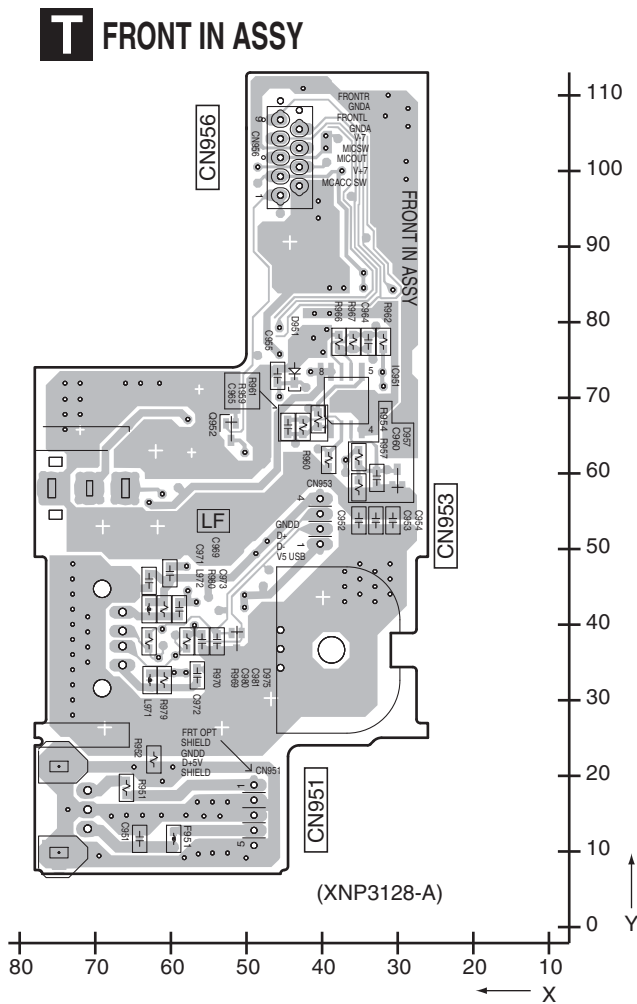
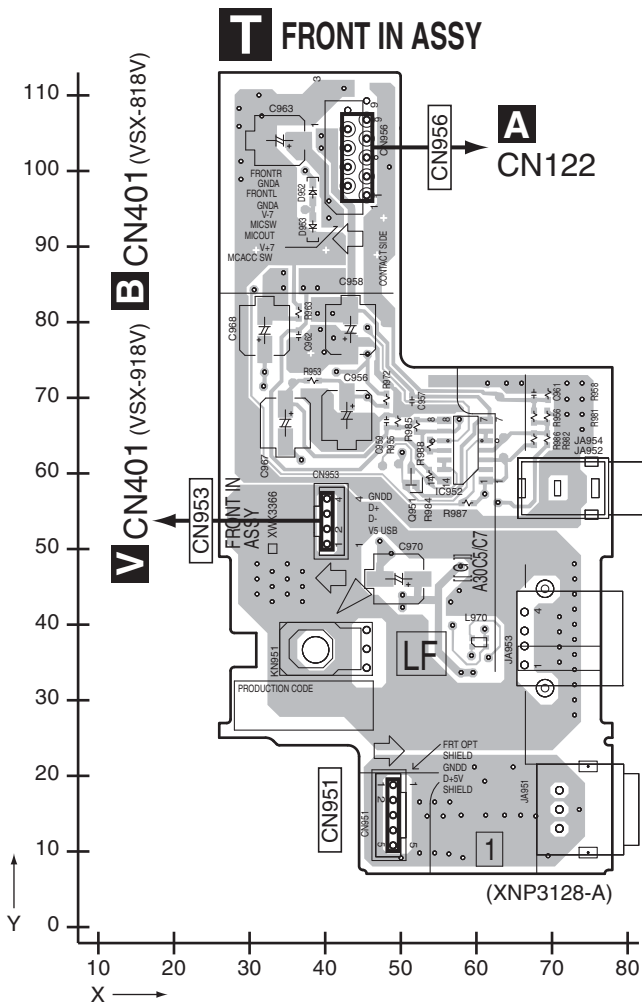

**T**

**T**

# 11.12 PRIMARY ASSY

SIDE A

SIDE A

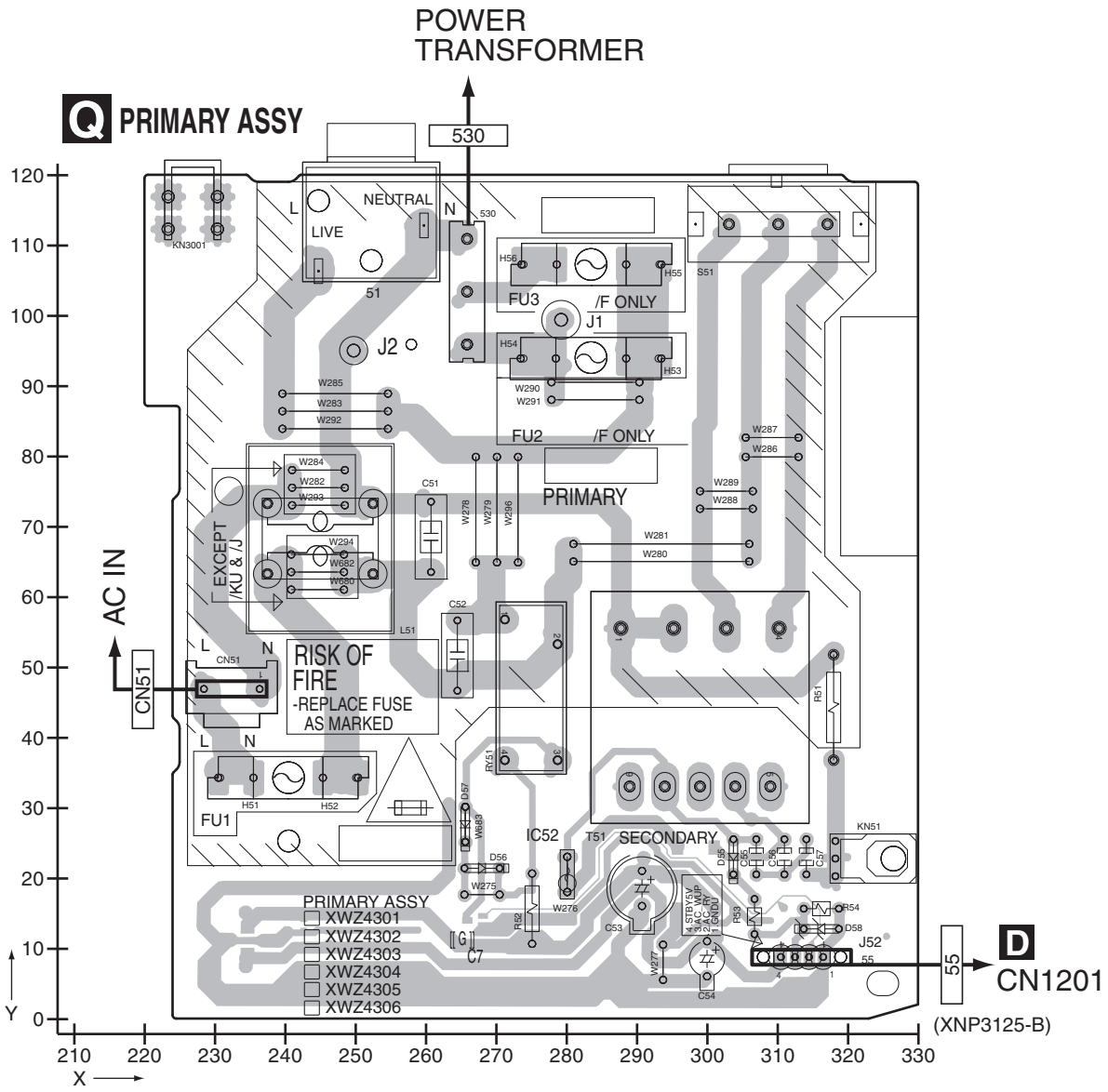

SIDE B

SIDE B

A

B

C

D

E

F

# Q PRIMARY ASSY

530

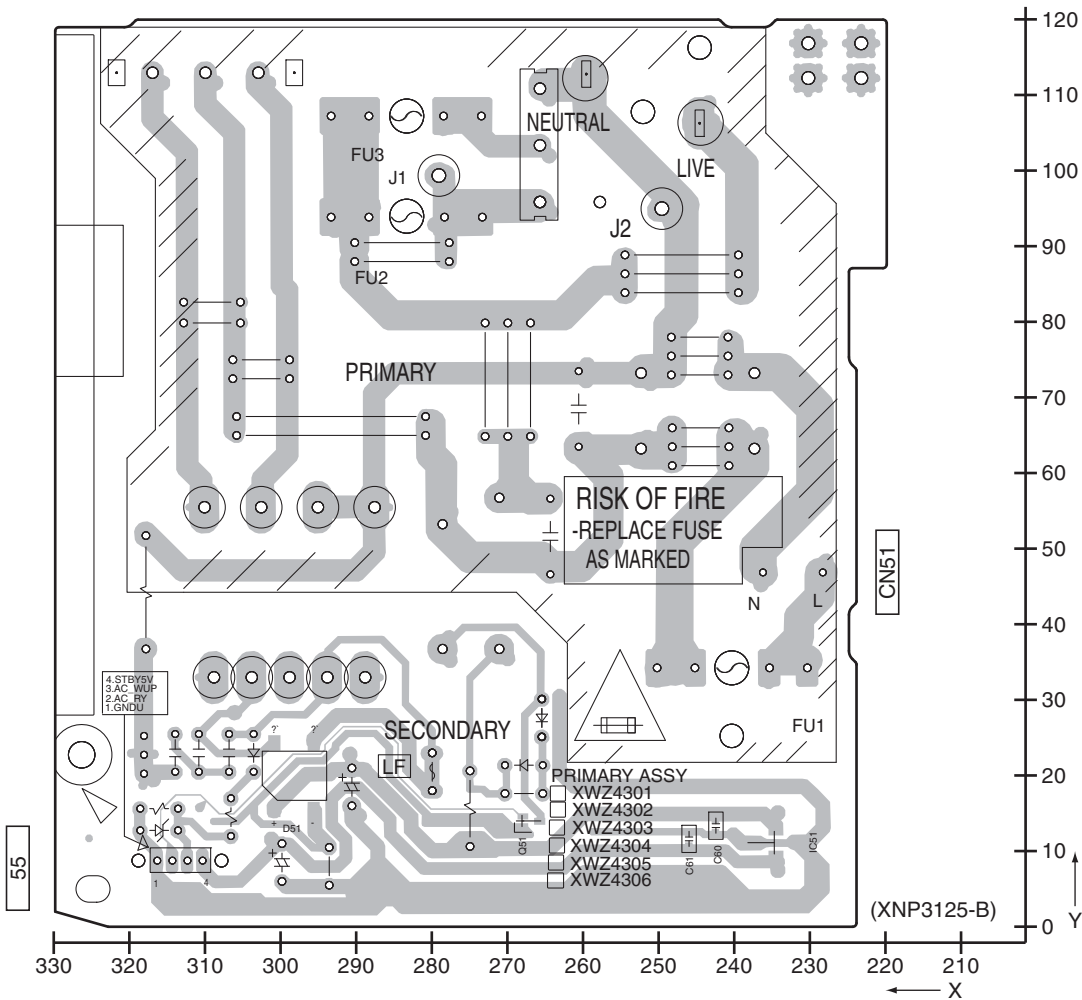

55

CN51

(XNP3125-B)

VSX-918V-K



# 11.13 HDMI & DSP & USB ASSY

**SIDE A**

## V HDMI&DSP&USB ASSY

IC Q

- IC462
- IC611
- IC871
- IC801
- IC401
- IC651
- IC61
- IC891
- IC71
- IC701
- IC271
- IC91
- IC121
- IC481
- IC502
- IC504
- IC201
- IC503
- IC2
- IC122
- IC1
- IC171
- IC181
- IC101
- IC261
- IC561
- IC301
- IC262
- IC251

- Q602
- Q601
- Q611
- Q73
- Q74
- Q72
- Q604
- Q603

- Q751
- Q341
- Q504

- Q753
- Q401
- Q402
- Q201

**T** CN953

CN401

**A** CN112

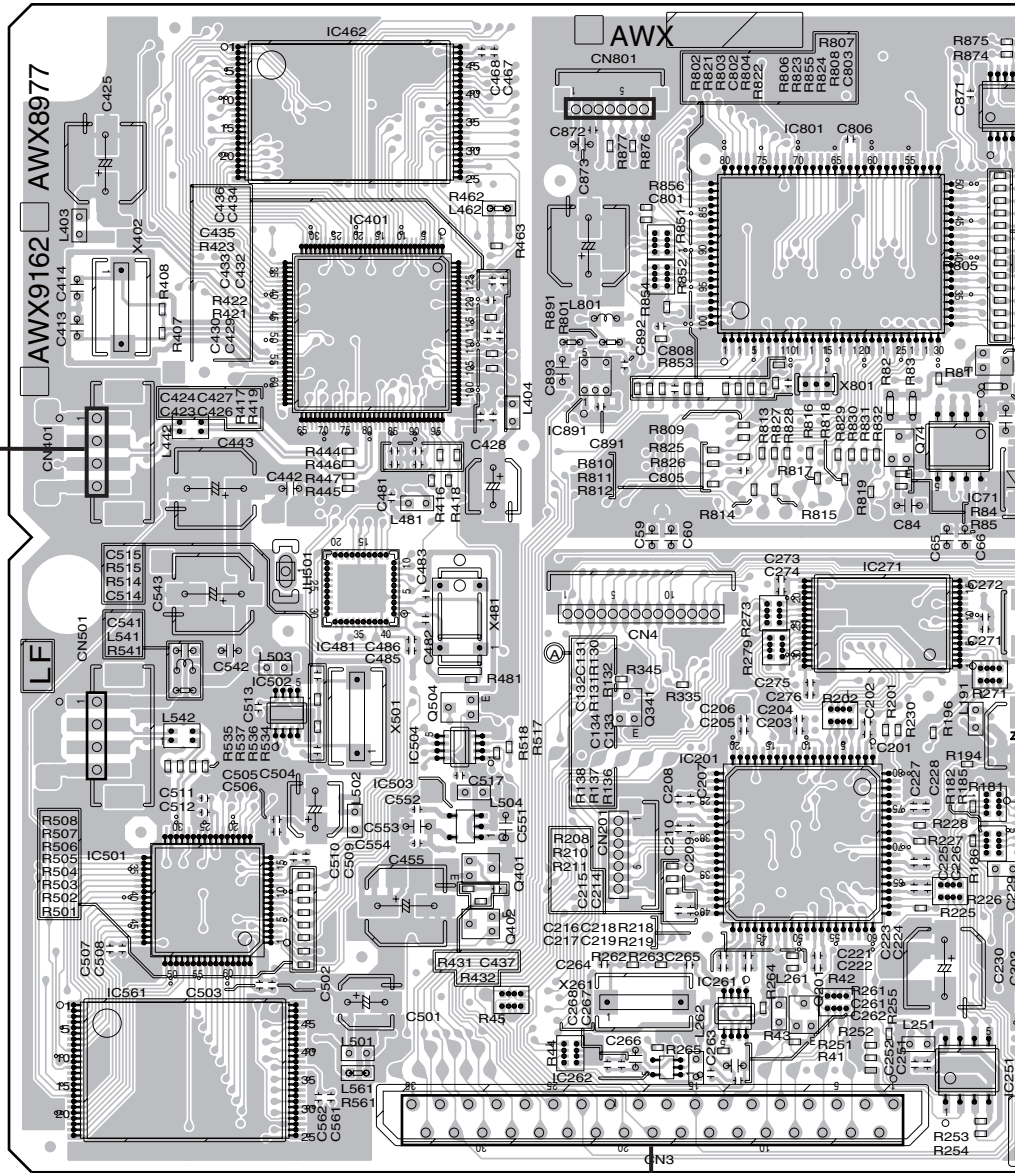

VSX-918V-K

SIDE A

A  
B  
C  
D  
E  
F

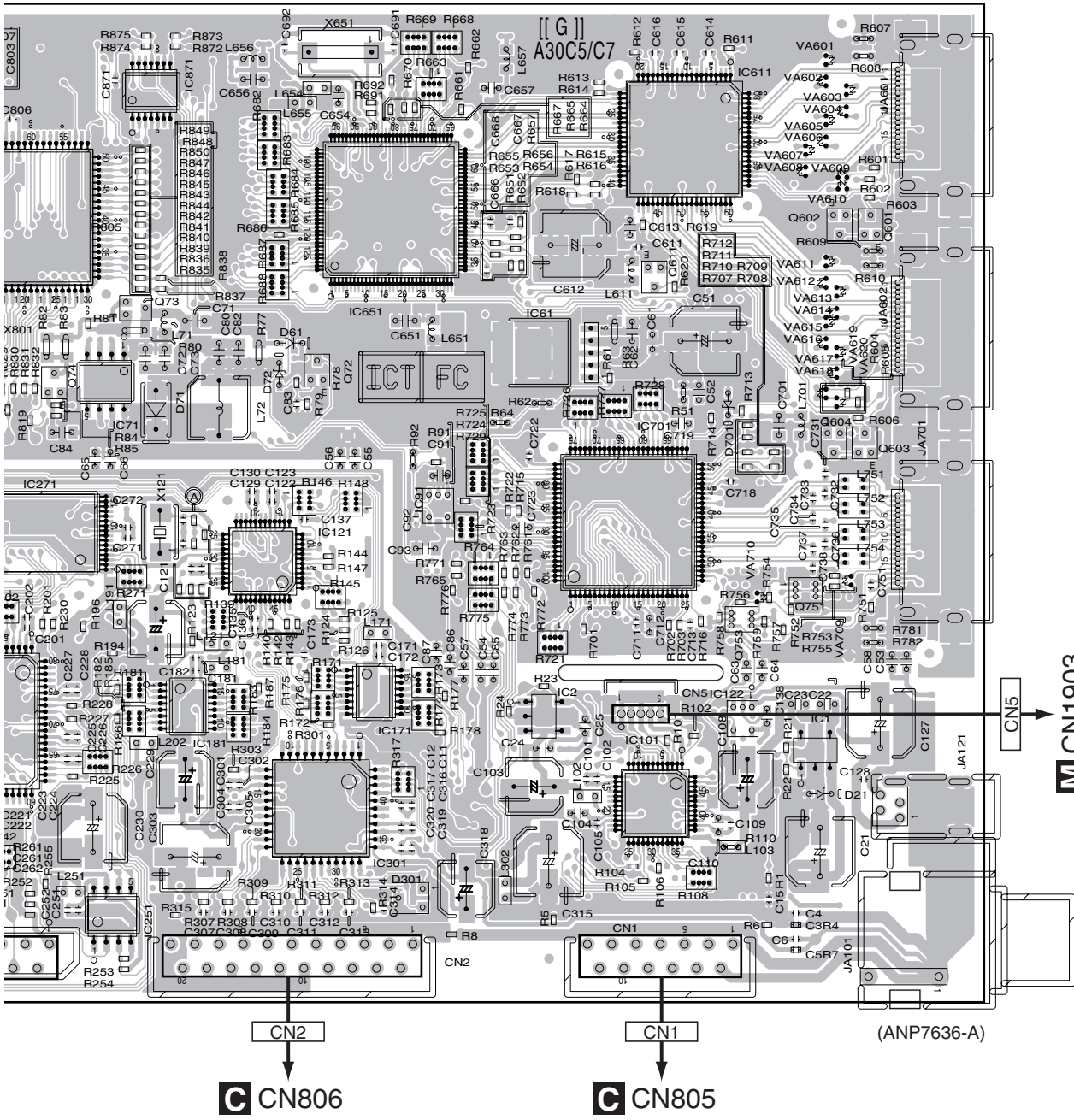

VSX-918V-K

V





# 12. ELECTRICAL PARTS LIST

NOTES: ● Parts marked by "NSP" are generally unavailable because they are not in our Master Spare Parts List.

● The  $\Delta$  mark found on some component parts indicates the importance of the safety factor of the part. Therefore, when replacing, be sure to use parts of identical designation.

● When ordering resistors, first convert resistance values into code form as shown in the following examples.

Ex.1 When there are 2 effective digits (any digit apart from 0), such as 560 ohm and 47k ohm (tolerance is shown by J=5%, and K=10%).

560  $\Omega$   $\rightarrow$  56 x 10<sup>1</sup>  $\rightarrow$  561 ..... RD1/4PU  $\overline{561}$  J

47k  $\Omega$   $\rightarrow$  47 x 10<sup>3</sup>  $\rightarrow$  473 ..... RD1/4PU  $\overline{473}$  J

0.5  $\Omega$   $\rightarrow$  R50 ..... RN2H  $\overline{R50}$  K

1  $\Omega$   $\rightarrow$  1R0 ..... RS1P  $\overline{1R0}$  K

Ex.2 When there are 3 effective digits (such as in high precision metal film resistors).

5.62k  $\Omega$   $\rightarrow$  562 x 10<sup>1</sup>  $\rightarrow$  5621 ..... RN1/4PC  $\overline{5621}$  F

● Meaning of the figures and others in the parentheses in the parts list.

Example) IC 301 is on the point (face A, 91 of x-axis, and 111 of y-axis) of the corresponding PC board.

IC 301 (A, 91, 111) IC NJM2068V

Mark No.	Description	Part No.	Mark No.	Description	Part No.
<b>LIST OF ASSEMBLIES</b>			NSP	1..COMPLEX ASSY (VSX-918V)	XWK3341
	1..MAIN ASSY (VSX-918V)	XWK3363	NSP	1..COMPLEX ASSY (VSX-818V)	XWK3336
	1..MAIN ASSY (VSX-818V)	XWK3359		2..FRONT DISPLAY ASSY (VSX-918V)	XWZ4285
	1..HDMI & DSP & USB ASSY (VSX-918V)	AWX8977		2..FRONT DISPLAY ASSY (VSX-818V)	XWZ4284
	1..HDMI ASSY (VSX-818V)	AWX8966		2..ROTARY ENCODER ASSY	XWZ4286
	1..DSP & USB ASSY (VSX-818V)	AWX9164		2..POWER KEY ASSY (VSX-918V)	XWZ4288
NSP	1..AMP ASSY	XWK3349		2..POWER KEY ASSY (VSX-818V)	XWZ4287
	2..POWER PACK ASSY	XWZ4326		2..JOG ASSY	XWZ4289
	2..TRANS2 ASSY	XWZ4335		2..VIDEO ASSY (VSX-918V)	XWZ4294
	2..TRANS3 ASSY	XWZ4337		2..VIDEO ASSY (VSX-818V)	XWZ4292
	2..COMPONENT VIDEO ASSY	XWZ4339		2..DIGITAL INPUT ASSY	XWZ4299
	2..5.1CH INPUT ASSY	XWZ4341		2..FRONT VIDEO ASSY	XWZ4300
	2..BIND ASSY	XWZ4344		2..PRIMARY ASSY	XWZ4302
				2..REGULATOR ASSY	XWZ4317
				2..HEAD PHONE ASSY	XWZ4321
				1..FRONT IN ASSY	XWK3366
				1..FM/AM TUNER UNIT	AXX7170

## CONTRAST OF PCB ASSEMBLIES

### A MAIN ASSY

XWK3363 and XWK3359 are constructed the same except for the following:

Mark	Symbol and Description	XWK3363	XWK3359
	IC9001	PEG469A8	PEG467A8
	D9067	1SS355	Not used
	CN130 13P FFC Connector	Not used	9604S-13C
	CN104 7P FFC Connector	Not used	9604S-07C
	CN112 FFC Connector	9604S-35C	CKS3392
	CN129 19P FFC Connector	9604S-19C	Not used
	R9024, R9063	RS1/16S103J	Not used
	R9025	RS1/16S332J	RS1/16S562J
	R9026	Not used	RS1/16S103J
	R9027, R9029	RS1/16S221J	Not used
	R9097	Not used	RS1/16S0R0J
	R9098	RS1/16S0R0J	Not used

## H FRONT DISPLAY ASSY

XWZ4285 and XWZ4284 are constructed the same except for the following:

Mark	Symbol and Description	XWZ4285	XWZ4284
	Q441	RT1N241M	Not used
	D404, D405	1SS355	Not used
	D502	SLR343BC4T(JKLM)	Not used
	R404	RS1/16S472J	Not used
	R430	Not used	RS1/16S0R0J
	R551	RS1/16S391J	Not used

## J POWER KEY ASSY

XWZ4288 and XWZ4287 are constructed the same except for the following:

Mark	Symbol and Description	XWZ4288	XWZ4287
	D501	SLR343BC4T(JKLM)	Not used
	R501	RS1/16S391J	Not used

## P VIDEO ASSY

XWZ4294 and XWZ4292 are constructed the same except for the following:

Mark	Symbol and Description	XWZ4294	XWZ4292
	L302-L306 Chip Solid Inductor	QTL1013	Not used
	CN303 Connector	9604S-19C	Not used
	CN304 13P FFC Connector	Not used	9604S-13C
	JA351 Mini Jack(4P) /W SW	XKN3015	Not used
	JA352 Jack	VKB1243	Not used
	R394	RS1/16S0R0J	Not used
	C379	CKSRYP103K50	Not used

## PCB PARTS LIST FOR VSX-918V/MYSXJ5 UNLESS OTHER WISE NOTED

Mark No.	Description	Part No.	Mark No.	Description	Part No.
<b>COMPLEX ASSY</b>			Q 256 (A,61,95)	CHIP TRANSISTOR	2SD2704K
<b>MISCELLANEOUS</b>			Q 257 (A,76,112)	TRANSISTOR	2SA1576A
J 41	JUMPER WIRE	D15A03-100-2651	Q 259 (B,61,108)	DIGITAL TR(SC-70)	RT1P241M
J 42	JUMPER WIRE	D15A05-125-2651	Q 260 (A,56,107)	TRANSISTOR	2SC4081
J 44	JUMPER WIRE	D15A03-100-2651	Q 361 (A,181,72)	TRANSISTOR	2SC5938A
			Q 6001 (A,140,24)	TRANSISTOR	RT1N241M
			Q 9001 (A,91,94)	DIGITAL TR(SC-70)	RT1N431M
			Q 9002 (A,66,80)	DIGITAL TR(SC-70)	RT1P241M
			Q 9003 (A,65,75)	DIGITAL TR(SC-70)	RT1P241M
			Q 9007 (A,69,85)	TRANSISTOR	DTC143TK
			Q 9064 (A,59,80)	DIGITAL TR(SC-70)	RT1P241M
			Q 9065 (A,55,78)	TRANSISTOR	UMD2N
			D 103 (B,177,35)	DIODE	DAN217U
			D 105 (B,170,35)	DIODE	DAN217U
			D 107 (B,174,37)	DIODE	DAN217U
			D 251 (A,138,88)	DIODE	DAN217U
			D 253 (B,55,108)	DIODE	UDZS13(B)
			D 254 (A,72,113)	DIODE	UDZS5R1(B)
			D 255 (B,53,109)	DIODE	UDZS13(B)
			D 311 (B,258,96)	DIODE	1SS355
			D 312 (B,269,98)	DIODE	1SS355
			D 331 (B,254,91)	DIODE	UDZS6R8(B)
			D 332 (B,271,91)	DIODE	UDZS6R8(B)
			D 6001 (A,146,21)	DIODE	1SS355
			D 9006 (B,99,89)	DIODE	DAN217U
			D 9007 (B,91,89)	DIODE	DAN217U
IC 103 (A,215,73)	DUAL OP-AMP	NJM4565MD			
IC 104 (A,198,56)	DUAL OP-AMP	NJM4565MD			
IC 105 (A,217,87)	DUAL OP-AMP	NJM4565MD			
IC 108 (B,253,65)	6CH E-VOL IC	BD3474KS2			
IC 251 (A,134,89)	DUAL OP-AMP	NJM4565MD			
IC 5001 (A,69,19)	RDS RECORDER IC	LC72725KM			
IC 6001 (A,135,20)	IC	TC74VHCT125AFTS1			
IC 9001 (B,82,64)	SYSTEM CONTROL MICON	PEG469A8			
IC 9002 (A,104,42)	EEPROM	BR24L16FV-W			
IC 9004 (A,128,49)	LOGIC IC	TC4094BFN			
Q 248 (A,53,103)	TRANSISTOR	2SC4081			
Q 249 (A,61,107)	TRANSISTOR	RT1N241M			
Q 250 (A,60,112)	TRANSISTOR	2SC4081			
Q 252 (A,65,105)	TRANSISTOR	2SD1858X			
Q 253 (A,53,99)	TRANSISTOR	RT1N241M			
Q 254 (B,61,103)	DIGITAL TR(SC-70)	RT1P241M			
Q 255 (A,61,99)	TRANSISTOR	2SC4081			

## A MAIN ASSY

### MISCELLANEOUS

IC 103 (A,215,73)	DUAL OP-AMP	NJM4565MD			
IC 104 (A,198,56)	DUAL OP-AMP	NJM4565MD			
IC 105 (A,217,87)	DUAL OP-AMP	NJM4565MD			
IC 108 (B,253,65)	6CH E-VOL IC	BD3474KS2			
IC 251 (A,134,89)	DUAL OP-AMP	NJM4565MD			
IC 5001 (A,69,19)	RDS RECORDER IC	LC72725KM			
IC 6001 (A,135,20)	IC	TC74VHCT125AFTS1			
IC 9001 (B,82,64)	SYSTEM CONTROL MICON	PEG469A8			
IC 9002 (A,104,42)	EEPROM	BR24L16FV-W			
IC 9004 (A,128,49)	LOGIC IC	TC4094BFN			
Q 248 (A,53,103)	TRANSISTOR	2SC4081			
Q 249 (A,61,107)	TRANSISTOR	RT1N241M			
Q 250 (A,60,112)	TRANSISTOR	2SC4081			
Q 252 (A,65,105)	TRANSISTOR	2SD1858X			
Q 253 (A,53,99)	TRANSISTOR	RT1N241M			
Q 254 (B,61,103)	DIGITAL TR(SC-70)	RT1P241M			
Q 255 (A,61,99)	TRANSISTOR	2SC4081			

Mark No.	Description	Part No.	Mark No.	Description	Part No.
D 9010 (A,97,93)	DIODE	1SS355	R 201 (A,208,85)		RS1/16S473J
D 9011 (A,60,75)	DIODE	DAN202U	R 202 (A,207,90)		RS1/16S473J
A	D 9064 (A,58,75)	DIODE	R 205 (B,208,85)		RS1/16S392J
	D 9065 (A,63,80)	DIODE	R 206 (B,208,91)		RS1/16S392J
	D 9067 (B,45,72)	DIODE	R 207 (B,210,85)		RS1/16S392J
	D 9068 (A,50,81)	DIODE		R 208 (B,210,91)	RS1/16S392J
	L 101 (B,260,98)	CHIP SOLID INDUCTOR	QTL1013	R 209 (B,216,85)	RS1/16S392J
				R 210 (B,216,91)	RS1/16S392J
L	L 102 (B,267,97)	CHIP SOLID INDUCTOR	R 211 (B,219,85)		RS1/16S332J
	L 5002 (A,257,104)	CHIP SOLID INDUCTOR	R 212 (B,219,91)		RS1/16S332J
	L 9001 (A,124,102)	CHIP SOLID INDUCTOR		R 241 (A,206,70)	RS1/16S473J
	L 9002 (A,120,103)	CHIP SOLID INDUCTOR		R 242 (A,206,75)	RS1/16S473J
	L 9003 (A,86,97)	RADIAL INDUCTOR	LFCA2R2J	R 245 (B,205,70)	RS1/16S332J
				R 246 (B,205,76)	RS1/16S332J
X	X 5001 (A,67,27)	CRYSTAL RESONATOR (4.332 MHz)	ASS7004	R 247 (B,207,70)	RS1/16S332J
	X 9001 (A,96,53)	CERAMIC RESONATOR (15.7 MHz)	XSS3004		
CN	CN 101 (A,41,27)	CONNECTOR	9604S-17C	R 248 (B,207,76)	RS1/16S332J
	CN 102 (A,113,61)	CONNECTOR	9604S-10C	R 249 (B,214,70)	RS1/16S332J
	CN 103 (A,227,17)	11P CONNECTOR	52044-1145	R 250 (B,214,76)	RS1/16S332J
CN	CN 105 (A,266,34)	CONNECTOR	9604S-07C	R 251 (B,216,70)	RS1/16S182J
	CN 107 (A,39,109)	CONNECTOR POST	B3B-PH-K-S	R 252 (B,216,76)	RS1/16S182J
	CN 109 (A,213,113)	15P SOCKET	XKP3090	R 261 (A,189,53)	RS1/16S473J
	CN 110 (A,169,113)	17P SOCKET	XKP3059	R 262 (A,189,59)	RS1/16S473J
	CN 111 (A,274,113)	21P SOCKET	XKP3091	R 264 (B,186,60)	RS1/16S392J
				R 265 (B,188,53)	RS1/16S332J
CN	CN 112 (A,91,41)	CONNECTOR	9604S-35C	R 266 (B,188,60)	RS1/16S472J
	CN 122 (A,41,58)	CONNECTOR	9604S-09C		
	CN 129 (A,247,13)	CONNECTOR	9604S-19C	R 267 (B,190,53)	RS1/16S332J
	CN 141 (A,302,21)	8P PIN JACK	XKB3064	R 268 (B,190,60)	RS1/16S123J
	CN 142 (A,302,98)	8P PIN JACK	XKB3067	R 269 (B,197,53)	RS1/16S332J
				R 270 (B,197,60)	RS1/16S122J
CN	CN 251 (A,39,92)	3P JUMPER CONNECTOR	52147-0310	R 271 (B,199,53)	RS1/16S182J
	CN 252 (A,37,77)	3P TOP POST	B3B-EH	R 272 (B,199,60)	RS1/16S272J
	102	PCB BINDER	VEF1040	R 274 (B,202,60)	RS1/16S271J
	101	PCB BINDER	VEF1040	R 303 (B,163,37)	RS1/16S101J
				R 304 (B,158,49)	RS1/16S101J
				R 305 (B,163,49)	RS1/16S101J
<b>RESISTORS</b>					
R	R 101 (B,282,19)		RS1/16S331J	R 306 (B,164,61)	RS1/16S101J
	R 102 (B,293,12)		RS1/16S331J	R 307 (B,165,68)	RS1/16S101J
	R 103 (B,283,62)		RS1/16S222J	R 308 (B,173,73)	RS1/16S101J
	R 104 (B,283,52)		RS1/16S222J	R 311 (A,258,102)	METAL OXIDE RESISTOR
	R 105 (B,283,48)		RS1/16S331J	R 312 (A,266,102)	METAL OXIDE RESISTOR
R	R 106 (B,293,40)		RS1/16S331J		
	R 107 (B,283,88)		RS1/16S331J	R 430 (A,137,91)	RS1/16S104J
	R 108 (B,293,81)		RS1/16S331J	R 431 (A,130,95)	RS1/16S104J
	R 109 (B,283,75)		RS1/16S331J	R 432 (A,130,100)	RS1/16S104J
	R 110 (B,293,68)		RS1/16S331J	R 433 (A,137,99)	RS1/16S683J
				R 434 (A,136,94)	RS1/16S393J
R	R 111 (B,283,112)		RS1/16S222J		
	R 112 (B,283,106)		RS1/16S222J	R 435 (A,134,97)	RS1/16S683J
	R 113 (B,283,101)		RS1/16S331J	R 436 (A,137,102)	RS1/16S683J
	R 114 (B,293,96)		RS1/16S331J	R 437 (A,53,106)	RS1/16S103J
	R 129 (B,283,34)		RS1/16S331J	R 438 (A,54,110)	RS1/16S103J
			R 439 (A,56,110)	RS1/16S103J	
R	R 130 (B,283,25)		RS1/16S331J		
	R 145 (A,70,73)		RS1/16S102J	R 440 (A,63,113)	RS1/16S103J
	R 146 (A,71,74)		RS1/16S102J	R 441 (A,146,94)	RS1/16S222J
	R 147 (B,231,59)		RS1/16S102J	R 442 (A,149,95)	RS1/16S104J
	R 148 (B,233,51)		RS1/16S102J	R 443 (B,57,108)	RS1/16S471J
				R 444 (A,139,91)	RS1/16S104J
R	R 149 (B,263,57)		RS1/16S104J		
	R 180 (B,278,97)		RS1/16SOR0J	R 445 (A,55,101)	RS1/16S223J
	R 181 (B,273,78)		RS1/16SOR0J	R 447 (A,65,96)	RS1/16S472J
	R 182 (B,275,75)		RS1/16SOR0J	R 448 (A,70,113)	RS1/16S104J
	R 183 (B,276,67)		RS1/16SOR0J	R 449 (A,65,113)	RS1/16S822J
			R 452 (A,153,44)	RS1/16SOR0J	



Mark No.	Description	Part No.	Mark No.	Description	Part No.
C 136	(A,280,106)	CEAT100M50	C 266	(A,194,59)	CCSRCH221J50
C 137	(A,280,101)	CEAT100M50	C 267	(B,193,53)	CCSRCH331J50
A			C 268	(B,193,60)	CCSRCH101J50
C 138	(A,280,93)	CEAT100M50	C 271	(A,202,53)	CKSRBY103K50
C 139	(A,50,101)	CEAT100M50	C 272	(A,202,58)	CKSRBY103K50
C 140	(A,50,94)	CEAT100M50	C 325	(A,143,39) ELECT. CAPACITOR	CEAT220M50
C 141	(B,236,50)	CKSRBY104K50	C 326	(A,143,46) ELECT. CAPACITOR	CEAT220M50
C 145	(B,238,54)	CCSRCH101J50	C 333	(A,251,93)	CEAT101M10
C 146	(B,238,50)	CCSRCH101J50	C 334	(A,268,81)	CEAT101M10
C 147	(A,249,68)	CKSRBY103K50	C 345	(A,145,57) ELECT. CAPACITOR	CEAT220M50
C 148	(B,229,61)	CKSRBY223K25	C 346	(A,145,64) ELECT. CAPACITOR	CEAT220M50
C 149	(B,240,59)	CKSRBY473K25	C 362	(A,185,79)	CEAT100M50
C 150	(B,237,59)	CKSQYB154K16	C 365	(A,142,73) ELECT. CAPACITOR	CEAT220M50
B			C 366	(A,142,80) ELECT. CAPACITOR	CEANP4R7M50
C 151	(B,234,62)	CKSRBY103K50	C 392	(B,91,97)	CKSRBY102K50
C 152	(B,235,54)	CKSRBY223K25	C 1031	(A,286,65)	CCSRCH220J50
C 153	(B,233,56)	CKSRBY473K25	C 1041	(B,287,55)	CCSRCH220J50
C 154	(B,230,53)	CKSQYB154K16	C 5001	(B,230,10)	CKSRBY102K50
C 155	(A,225,43)	CEAT470M25	C 5002	(B,232,10)	CKSRBY103K50
C 165	(A,236,86)	CEAT1R0M50	C 5003	(B,234,10)	CKSRBY105K10
C 166	(A,243,86)	CEAT1R0M50	C 5011	(A,77,16)	CEJQ100M50
C 179	(B,294,76)	CKSRBY103K50	C 5013	(A,61,28)	CCSRCH270J50
C 180	(A,277,19)	CKSRBY103K50	C 5014	(A,63,28)	CCSRCH270J50
C 181	(A,283,30)	CCSRCH101J50	C 5015	(A,59,20)	CEJQ470M16
C 182	(B,285,28)	CCSRCH101J50	C 5016	(A,62,22)	CKSRBY103K50
C 183	(B,287,14)	CCSRCH101J50	C 5017	(A,73,14)	CCSRCH561J50
C 184	(B,285,14)	CCSRCH101J50	C 5020	(A,69,13)	CKSRBY472K50
C 185	(B,283,44)	CCSRCH101J50	C 5025	(A,159,11)	CKSRBY102K50
C 186	(B,288,42)	CCSRCH101J50	C 5026	(A,162,12)	CKSRBY102K50
C 187	(B,283,84)	CCSRCH101J50	C 5027	(A,167,14)	CKSRBY102K50
C 188	(B,285,83)	CCSRCH101J50	C 5028	(A,180,15)	CCSRCH220J50
C 189	(B,283,71)	CCSRCH101J50	C 6001	(A,139,18)	CKSRBY104K16
C 190	(B,287,70)	CCSRCH101J50	C 9004	(B,84,88)	CKSRBY103K50
C 191	(B,283,97)	CCSRCH101J50	C 9005	(A,78,106)	CEJQ2R2M50
C 192	(B,285,96)	CCSRCH101J50	C 9006	(A,95,93)	CKSRBY105K10
C 197	(B,292,29)	CCSRCH101J50	C 9007	(A,79,92) ELECT. CAPACITOR	CEAT331M6R3
C 198	(B,294,25)	CCSRCH101J50	C 9008	(B,77,90)	CKSRBY103K50
C 199	(A,281,50)	CKSRBY103K50	C 9011	(B,95,89)	CKSRBY473K16
C 201	(A,202,85)	CEAT2R2M50	C 9014	(B,87,88)	CKSRBY473K16
C 202	(A,203,92)	CEAT2R2M50	C 9015	(A,94,102)	CKSRBY102K50
C 205	(A,212,85)	CCSRCH331J50	C 9017	(A,129,55)	CKSRBY104K50
C 206	(A,212,90)	CCSRCH331J50	C 9018	(B,72,72)	CKSRBY104K50
C 207	(B,212,85)	CCSRCH331J50	C 9030	(A,272,106)	CEAT101M25
C 208	(B,212,91)	CCSRCH331J50	C 9081	(A,121,69)	CKSRBY103K50
C 217	(A,221,85)	CKSRBY103K50			
C 218	(A,221,90)	CKSRBY103K50			
C 241	(A,200,71)	CEAT2R2M50			
C 242	(A,200,78)	CEAT2R2M50			
C 245	(A,211,70)	CCSRCH331J50			
C 246	(A,211,75)	CCSRCH331J50			
C 247	(B,209,70)	CCSRCH331J50			
C 248	(B,209,76)	CCSRCH331J50			
C 251	(A,219,68)	CKSRBY103K50			
C 252	(A,219,75)	CKSRBY103K50			
C 253	(A,130,91)	CKSRBY103K50			
C 254	(A,157,96)	CEAT101M25			
C 256	(A,135,84)	CKSRBY103K50			
C 261	(A,183,54)	CEAT2R2M50			
C 262	(A,183,62)	CEAT2R2M50			
C 264	(A,191,59)	CCSRCH331J50			
C 265	(A,194,53)	CCSRCH331J50			

## **B** DSP & USB ASSY (VSX-818V-K) **SEMICONDUCTORS**

△ IC 1,2	PQ1LAX95MSPQ
IC 101	AK4114VQ
IC 191,331	TC74VHC08FTS1
IC 201	DSPC56371AF180
IC 202	TC7WH125FU
IC 251	PDC172A8
IC 261	TC7WHU04FU
IC 271	ML87V5002
IC 301	AK4626AVQ
IC 351	TC74VHCT541AFTS1
IC 401	TCC8600-00X-EA-UG

Mark No.	Description	Part No.	Mark No.	Description	Part No.
△ IC 402		S-1200B18-M5	C 21,230,303,315		CEVW101M16
IC 461		HY57V641620FTP-6			
IC 462		AYW7236	C 22-25		CKSRYP105K10
△ IC 471		AAT4618IGV-0.5-1	C 103,108,318		CEVW470M6R3
			C 104,110,192,261		CCSRCH471J50
IC 481		341S2154	C 109,191,202,204		CKSSYP104K10
Q 201		RT1N241M	C 111		CKSRYP474K10
Q 401		2SA1577			
Q 402,471		RT1N431M	C 206,208,210,215		CKSSYP104K10
D 1,21		UDZS5R6(B)	C 214,216,218,221		CKSSYP471K50
			C 217,219,222,224		CKSSYP104K10
D 301		MA152WA	C 225,309-314,317		CKSSYP471K50
D 302		MA152WK	C 226,228,232,252		CKSSYP104K10

### MISCELLANEOUS

L 1-3 CHIP SOLID INDUCTOR	ATL7002	C 229	CEVW101M4
L 101,102 CHIP SOLID INDUCTOR	QTL1013	C 262,271,273,275	CKSSYP104K10
L 191,201 CHIP SOLID INDUCTOR	QTL1013	C 264,265	CCSSCH8R0D50
L 202,203 CHIP SOLID INDUCTOR	ATL7002	C 277,304,306,316	CKSSYP104K10
L 204,251 CHIP SOLID INDUCTOR	QTL1013	C 305,484	CCSSCH101J50
L 261,271 CHIP SOLID INDUCTOR	QTL1013	C 320,332,352,401	CKSSYP104K10
L 301,302 CHIP SOLID INDUCTOR	QTL1013	C 402,404,406,408	CKSSYP471K50
L 331,351 CHIP SOLID INDUCTOR	QTL1013	C 403,405,407,409	CKSSYP104K10
L 401,403 CHIP SOLID INDUCTOR	QTL1013	C 410,412,416,418	CKSSYP471K50
L 402 INDUCTOR	LCTC100K1608	C 411,415,417,419	CKSSYP104K10
L 404,461 CHIP SOLID INDUCTOR	QTL1013	C 413	CCSRCH100D50
L 441 CHIP FERRITE BEADS	VTL1169	C 414	CCSRCH471J50
L 442 COIL	VTH1043	C 420	CKSSYP122K50
L 462,481 CHIP SOLID INDUCTOR	QTL1013	C 421	CKSQYB225K10
JA 101 JACK	VKB1159	C 422	CCSRCH331J50
X 261 CRYSTAL RESONATOR (24.576 MHz)	XSS3003	C 423,426,429,432	CKSSYP104K10
X 402 CRYSTAL OSCILLATOR	CSS1614	C 424,427,430,433	CKSSYP471K50
		C 425,443,455	CEVW101M16
		C 431	CKSSYP103K16
X 481 CRYSTAL OSCILLATOR (32.768 kHz)	ASS1172	C 434,454,461,467	CKSSYP104K10
CN 1 13P SOCKET	XKP3077	C 435,436,462-464	CKSSYP471K50
CN 2 21P SOCKET	XKP3081	C 441,442	CKSRYP104K16
		C 451,457	CKSRYP105K16
		C 466,468,486	CKSSYP471K50
CN 5,6 5P CONNECTOR	VKN1374	C 471	CKSSYP104K16
CN 8 CONNECTOR	9604S-27C		
CN 401 CONNECTOR	AKM1275		
JH 501 PCB BINDER	VEF1040	C 472	CKSQYB105K16
		C 481,485	CKSSYP104K10
		C 482,483	CCSSCH5R0C50

### RESISTORS

R 21	RS1/16SS2002F
R 22,24	RS1/16SS1202F
R 23	RS1/16SS1000F
R 42,44,45	RAB4CQ104J
R 103,108,202,271	RAB4CQ101J
R 110,442,443	RS1/16S0R0J
R 111	RS1/16SS1802F
R 191-193	RS1/16S101J
R 203	RAB4CQ103J
R 226,229,272	RAB4CQ470J
R 273,279,317,353	RAB4CQ101J
R 306	RS1/16S4R7J
R 354	RAB4CQ101J
R 488	RS1/16SS1003F
Other Resistors	RS1/16SS###J

### CAPACITORS

C 7,107,321,322	CKSSYP102K50
C 9,113,220,301	CKSSYP103K16
C 10,12,203,209	CKSSYP471K50
C 11,102,105,106	CKSSYP104K10

## POWER PACK ASSY MISCELLANEOUS

△ IC 601 (A,265,14) 2CH POWER IC	PAC014A
△ IC 603 (A,137,14) 3CH POWER IC	PAC015A
△ IC 610 (A,59,28) PROTECTOR(1A)	AEK7009
△ IC 701 (A,100,80) IC PROTECTOR	ICP-N10
△ IC 702 (A,84,81) IC PROTECTOR	ICP-N10
△ IC 803 (B,238,93) IC	BA05FP
△ IC 804 (A,279,111) REGULATOR IC	KIA7809API
△ IC 805 (B,270,132) LDO REGULATOR(5V)	NJM2831F05
Q 501 (B,91,38) TRANSISTOR	2SC5938A
Q 505 (A,116,47) TRANSISTOR	2SC2240
Q 601 (B,94,44) TRANSISTOR	2SC5938A
Q 602 (B,224,43) TRANSISTOR	2SC5938A
Q 605 (A,123,40) TRANSISTOR	2SC2240
Q 606 (A,252,40) TRANSISTOR	2SC2240
Q 652 (B,219,37) TRANSISTOR	2SC5938A
Q 656 (A,244,47) TRANSISTOR	2SC2240

Mark No.	Description	Part No.	Mark No.	Description	Part No.
Q 681	(B,82,48) TRANSISTOR	2SC5938A	KN 601	(A,65,23) WRAPPING TERMINAL	VNF1084
Q 683	(A,59,65) TRANSISTOR	2SC2240	RY 501	(A,75,132) RELAY	ASR7001
Q 696	(B,282,24) TRANSISTOR	2SC4081	RY 751	(A,173,130) RELAY	ASR7001
Q 697	(B,282,29) TRANSISTOR	2SC4081	RY 752	(A,141,126) RELAY	ASR7001
			RY 753	(A,117,120) RELAY	ASR7001
Q 698	(B,246,67) TRANSISTOR	RT1N241M			
△ Q 701	(A,110,72) TRANSISTOR	2SC5511	CN 701	(A,212,134) 11PJUMPER CONNECTOR	52147-1110
△ Q 702	(A,96,86) TRANSISTOR	2SA2005	CN 702	(A,200,106) 6P JUMPER CONNECTOR	52147-0610
Q 703	(A,155,76) TRANSISTOR	2SA1145	CN 704	(A,290,45) 17P PLUG	XKM3007
Q 704	(A,166,79) TRANSISTOR	2SC2240	CN 751	SP TERMINAL 4-P(V0)	XKE3044
			CN 752	SP TERMINAL 6-P(V0)	XKE3043
Q 721	(A,142,72) TRANSISTOR	2SA1145			
Q 722	(A,161,74) TRANSISTOR	2SC2240	CN 753	(A,70,179) SP TERMINAL 4-P(V0)	XKE3050
Q 724	(B,291,72) TRANSISTOR	RT1N241M	CN 803	(A,224,129) 6P PLUG	KM200TA6
Q 801	(B,271,141) DIGITAL TR(SC-70)	RT1P241M	CN 805	(A,317,153) 13P PLUG	XKP3066
Q 802	(B,271,145) TRANSISTOR	RT1N241M	CN 806	(A,317,120) 21P PLUG	XKP3070
			CN 815	(A,290,89) 15P PLUG	XKM3010
Q 803	(B,265,141) DIGITAL TR(SC-70)	RT1P241M			
Q 804	(B,268,141) TRANSISTOR	RT1N241M	CN 816	(A,290,126) 21P PLUG	XKM3011
Q 805	(B,274,143) DIGITAL TR(SC-70)	RT1P241M	810	(A,277,90) 11P CABLE HOLDER	51048-1100
Q 806	(B,267,146) TRANSISTOR	RT1N241M			
Q 807	(B,276,53) TRANSISTOR	RT3P22M			
			<b>RESISTORS</b>		
Q 808	(B,283,57) TRANSISTOR	RT3N22M	R 601	(A,99,48)	RD1/4PU102J
Q 810	(A,206,104) TRANSISTOR	2SD1858X	R 602	(A,228,42)	RD1/4PU102J
D 601	(A,127,57) DIODE	1SS133	R 603	(B,96,47)	RS1/16S103J
D 603	(A,121,57) DIODE	1SS133	R 604	(B,225,47)	RS1/16S103J
D 606	(A,260,57) DIODE	1SS133	R 609	(A,96,35)	RD1/4PU563J
			R 610	(A,225,35)	RD1/4PU563J
D 608	(A,253,52) DIODE	1SS133	R 611	(A,95,28)	RD1/4PU182J
D 652	(A,262,57) DIODE	1SS133	R 612	(A,223,28)	RD1/4PU182J
D 654	(A,242,52) DIODE	1SS133	R 613	(A,119,21)	RD1/4PU563J
D 683	(A,132,57) DIODE	1SS133	R 614	(A,247,21)	RD1/4PU563J
D 684	(A,65,72) DIODE	1SS133			
			R 615	(A,128,36)	RD1/4PU331J
D 701	(A,9,88) DIODE	D5SBA20(B)	△ R 617	(A,119,31) RESISTOR (0.22, 5W)	ACN7094
D 711	(A,195,103) ZENER DIODE	MTZJ22D	R 619	(A,124,52)	RD1/4PU182J
D 712	(A,191,103) DIODE	MTZJ6R8(B)	R 620	(A,257,36)	RD1/4PU331J
D 713	(A,114,77) DIODE	1SS133	R 621	(A,129,49)	RD1/4PU821J
D 741	(B,152,136) DIODE	1SS355			
			△ R 622	(A,248,31) RESISTOR (0.22, 5W)	ACN7094
D 742	(B,167,140) DIODE	1SS355	R 623	(A,121,48)	RD1/4PU223J
D 743	(B,121,129) DIODE	1SS355	R 624	(A,257,52)	RD1/4PU182J
D 744	(B,138,139) DIODE	1SS355	R 626	(A,258,49)	RD1/4PU821J
D 745	(B,115,129) DIODE	1SS355	R 628	(A,250,48)	RD1/4PU223J
D 751	(B,168,135) DIODE	1SS355			
			R 652	(A,215,36)	RD1/4PU102J
D 752	(B,170,135) DIODE	1SS355	R 654	(B,219,41)	RS1/16S103J
D 753	(B,138,132) DIODE	1SS355	R 660	(A,220,29)	RD1/4PU563J
D 754	(B,141,132) DIODE	1SS355	R 662	(A,216,20)	RD1/4PU182J
D 757	(B,70,136) DIODE	1SS355	R 664	(A,238,21)	RD1/4PU563J
D 758	(B,73,136) DIODE	1SS355			
			R 666	(A,240,35)	RD1/4PU331J
D 777	(A,130,57) DIODE	1SS133	△ R 668	(A,239,31) RESISTOR (0.22, 5W)	ACN7094
D 778	(A,110,57) DIODE	1SS133	R 670	(A,245,52)	RD1/4PU182J
D 801	(B,222,113) BRIDGE DIODE	S1WB(A)60SD	R 672	(A,240,57)	RD1/4PU821J
D 806	(A,283,65) DIODE	MTZJ6R2(B)	R 674	(A,236,38)	RD1/4PU223J
D 807	(A,280,70) DIODE	1SS133			
			R 681	(A,73,51)	RD1/4PU102J
D 827	(A,262,132) DIODE	MTZJ6R2(B)	R 682	(B,77,49)	RS1/16S103J
D 828	(A,227,99) DIODE	MTZJ6R2(B)	R 685	(B,80,37)	RS1/16S563J
D 829	(A,239,128) DIODE	D3SBA20(B)	R 686	(B,85,21)	RS1/16S182J
D 900	(A,213,94) DIODE	MTZJ7R5(B)	R 687	(A,88,11)	RD1/4PU563J
L 751	(A,160,108) COIL	ATH1004			
			R 690	(A,60,52)	RD1/4PU331J
L 752	(A,173,108) COIL	ATH1004	△ R 691	(A,55,55) RESISTOR (0.22, 5W)	ACN7094
L 753	(A,120,107) COIL	ATH1004	R 692	(A,70,72)	RD1/4PU182J
L 761	(A,130,108) COIL	ATH1004	R 693	(A,67,77)	RD1/4PU821J
L 762	(A,142,108) COIL	ATH1004	R 694	(A,62,72)	RD1/4PU223J
J 43	11P PARALLEL WIRE	XDX3066			
			R 696	(B,281,38)	RS1/16S103J

Mark No.	Description	Part No.	Mark No.	Description	Part No.
R 697	(B,255,68)	RS1/16S103J	C 521	(A,120,164) FILM CAPACITOR	CQMBA123J50
R 698	(B,243,67)	RS1/16S333J	C 603	(B,99,39)	CKSRYB331K50
R 701	(A,122,85)	RD1/4PU472J	C 604	(B,227,38)	CKSRYB331K50
R 702	(A,109,87)	RD1/4PU472J	C 605	(A,101,38)	CEAT4R7M50
			C 606	(A,230,38)	CEAT4R7M50
R 703	(A,151,72)	RD1/4PU392J			
R 704	(A,148,77)	RD1/4PU392J	C 607	(B,100,20)	CCSRCH470J50
R 705	(A,281,82)	RD1/4PU473J	C 608	(B,230,17)	CCSRCH470J50
R 706	(A,277,83)	RD1/4PU473J	C 609	(A,96,32)	CEAT101M16
R 707	(A,133,80)	RD1/4PU184J	C 610	(A,225,32)	CEAT101M16
			C 613	(B,121,27)	CCSRCJ3ROC50
R 708	(A,147,81)	RD1/4PU184J			
△ R 711	(A,181,86) METAL OXIDE RESISTOR	RS2LMF222J	C 614	(B,250,28)	CCSRCJ3ROC50
R 713	(A,114,85)	RD1/4PU102J	C 615	(A,121,45)	CEANP2R2M50
R 721	(A,145,77)	RD1/4PU103J	C 616	(A,250,45)	CEANP2R2M50
R 722	(A,125,78)	RD1/4PU103J	C 654	(B,217,33)	CKSRYB331K50
			C 656	(A,215,33)	CEAT4R7M50
R 723	(A,271,78)	RD1/4PU473J			
R 724	(A,274,83)	RD1/4PU473J	C 658	(B,221,17)	CCSRCH470J50
R 725	(A,276,74)	RD1/4PU103J	C 660	(A,219,25)	CEAT101M16
R 726	(B,286,62)	RS1/16S473J	C 664	(B,241,24)	CCSRCJ3ROC50
R 727	(B,283,62)	RS1/16S103J	C 666	(A,239,49)	CEANP2R2M50
			C 682	(B,80,43)	CKSRYB331K50
R 728	(B,106,9)	RS1/16S683J			
R 730	(B,214,14)	RS1/16S683J	C 683	(A,83,43)	CEAT4R7M50
R 731	(A,122,73)	RD1/4PU220J	C 684	(B,87,18)	CCSRCH470J50
R 732	(A,101,89)	RD1/4PU220J	C 685	(A,83,37)	CEAT101M16
R 740	(B,87,141)	RS1/16S683J	C 687	(B,87,8)	CCSRCJ3ROC50
			C 688	(A,75,78)	CEANP2R2M50
R 741	(B,152,140)	RS1/16S472J			
R 742	(B,169,143)	RS1/16S472J	C 696	(B,281,36)	CKSRYB102K50
R 743	(B,121,134)	RS1/16S472J	C 697	(A,286,29)	CEAT221M6R3
R 744	(B,137,143)	RS1/16S472J	C 701	(A,49,80) E-CAP 5600/71	XCH3027
R 745	(B,110,131)	RS1/16S472J	C 702	(A,49,107) E-CAP 5600/71	XCH3027
			C 705	(A,156,81) ELECT. CAPACITOR	CEAT100M2A
△ R 751	(A,158,119) CARBON FILM RESISTOR	RD1/4PUF101J			
△ R 752	(A,185,120) CARBON FILM RESISTOR	RD1/4PUF101J	C 706	(A,142,84) ELECT. CAPACITOR	CEAT100M2A
△ R 753	(A,156,126) METAL OXIDE RESISTOR	RS1LMF4R7J	C 711	(A,195,99) ELECT. CAPACITOR	CEAT101M35
△ R 754	(A,181,126) METAL OXIDE RESISTOR	RS1LMF4R7J	C 712	(A,188,105)	CEAT101M10
△ R 755	(A,103,117) CARBON FILM RESISTOR	RD1/4PUF101J	C 740	(A,90,136)	CEAT101M25
			C 751	(A,159,143) FILM CAPACITOR	CQMBA224J50
△ R 756	(A,101,126) METAL OXIDE RESISTOR	RS1LMF4R7J			
△ R 761	(A,125,117) CARBON FILM RESISTOR	RD1/4PUF101J	C 752	(A,181,150) FILM CAPACITOR	CQMBA224J50
△ R 762	(A,155,119) CARBON FILM RESISTOR	RD1/4PUF101J	C 753	(A,157,155) FILM CAPACITOR	CQMBA224J50
△ R 763	(A,124,132) METAL OXIDE RESISTOR	RS1LMF4R7J	C 754	(A,181,158) FILM CAPACITOR	CQMBA224J50
△ R 764	(A,149,139) METAL OXIDE RESISTOR	RS1LMF4R7J	C 755	(A,103,147) FILM CAPACITOR	CQMBA224J50
			C 756	(A,96,151) FILM CAPACITOR	CQMBA224J50
R 777	(A,86,37)	RD1/4PU102J			
R 778	(B,90,42)	RS1/16S103J	C 757	(A,157,164) FILM CAPACITOR	CQMBA123J50
R 781	(A,92,30)	RD1/4PU563J	C 758	(A,177,164) FILM CAPACITOR	CQMBA123J50
R 782	(A,89,22)	RD1/4PU182J	C 759	(A,101,164) FILM CAPACITOR	CQMBA123J50
R 783	(A,109,21)	RD1/4PU563J	C 761	(A,122,139) FILM CAPACITOR	CQMBA224J50
			C 762	(A,152,145) FILM CAPACITOR	CQMBA224J50
R 784	(A,116,35)	RD1/4PU331J			
△ R 785	(A,110,31) RESISTOR (0.22, 5W)	ACN7094	C 763	(A,122,146) FILM CAPACITOR	CQMBA224J50
R 786	(A,113,57)	RD1/4PU182J	C 764	(A,150,152) FILM CAPACITOR	CQMBA224J50
R 787	(A,106,59)	RD1/4PU821J	C 765	(A,63,164) FILM CAPACITOR	CQMBA123J50
R 788	(A,107,38)	RD1/4PU223J	C 766	(A,82,164) FILM CAPACITOR	CQMBA123J50
			C 773	(A,138,164) FILM CAPACITOR	CQMBA123J50
R 806	(B,280,48)	RS1/16S103J			
R 807	(B,278,48)	RS1/16S103J	C 778	(B,89,34)	CKSRYB331K50
R 808	(B,279,53)	RS1/16S102J	C 779	(A,86,33)	CEAT4R7M50
R 813	(B,273,131)	RS1/16S102J	C 780	(B,93,18)	CCSRCH470J50
R 900	(B,213,97)	RS1/16S102J	C 781	(A,92,27)	CEAT101M16
			C 783	(B,112,24)	CCSRCJ3ROC50
R 901	(B,210,98)	RS1/16S100J			
R 1101	(B,273,68)	RS1/16SOR0J	C 784	(A,110,48)	CEANP2R2M50
R 1102	(B,274,61)	RS1/16SOR0J	C 801	(A,248,114) ELECT. CAPACITOR	CEAT222M25
R 1109	(B,285,58)	RS1/16SOR0J	C 802	(A,249,100) ELECT. CAPACITOR	CEAT222M25
			C 806	(B,281,53)	CKSRYB105K16
			C 807	(B,233,89)	CKSRYB103K25

## CAPACITORS

Mark No.	Description	Part No.
C 808 (A,245,142)	ELECT. CAPACITOR	CEAT472M16
C 809 (A,232,95)		CEAT101M10
C 810 (A,266,133)		CEAT101M10
C 811 (B,276,128)		CKSRYB103K25
C 812 (B,272,111)		CKSRYB103K25
C 813 (A,272,118)		CEAT101M16
C 850 (A,210,92)		CEAT101M10
C 860 (A,282,159)		CEAT101M25
C 870 (B,249,134)		CKSRYB104K50
C 901 (B,216,92)		CKSRYB104K16

Mark No.	Description	Part No.
C 572 (B,267,214)		CKSRYB473K50
C 577 (B,213,214)		CKSRYB103K50
C 579 (A,205,205)		CEAT101M10
C 580 (A,199,205)		CEAT101M10
C 582 (B,212,199)		CKSRYB103K50

## **F** 5.1CH INPUT ASSY MISCELLANEOUS

CN 307 (A,125,216)	7P CONNECTOR	52044-0745
CN 309 (A,167,225)	PIN JACK(4P)	XKB3035

## RESISTORS

R 1001 (B,147,233)		RS1/16S474J
R 1002 (B,150,226)		RS1/16S474J
R 1003 (B,149,236)		RS1/16S331J
R 1004 (B,150,228)		RS1/16S331J
R 1009 (B,150,224)		RS1/16S474J
R 1010 (B,151,212)		RS1/16S474J
R 1011 (B,150,222)		RS1/16S331J
R 1012 (B,150,214)		RS1/16S331J

## CAPACITORS

C 1001 (B,151,233)		CCSRCH101J50
C 1002 (B,151,230)		CCSRCH101J50
C 1003 (B,143,233)		CKSRYB221K50
C 1004 (B,147,230)		CKSRYB221K50
C 1009 (A,146,236)		CEAT4R7M50
C 1010 (A,146,228)		CEAT4R7M50
C 1012 (B,159,226)		CKSRYB103K50
C 1013 (B,151,219)		CCSRCH101J50
C 1014 (B,151,216)		CCSRCH101J50
C 1015 (B,147,224)		CKSRYB221K50
C 1016 (B,147,216)		CKSRYB221K50
C 1021 (A,146,214)		CEAT4R7M50
C 1022 (A,146,221)		CEAT4R7M50

## **G** TRANS3 ASSY MISCELLANEOUS

⚠ IC 357 (A,100,225)	PROTECTOR(800MA)	AEK7008
D 363 (A,86,238)	DIODE	1SR139-400
J 22	3P PARALLEL WIRE	XDX3064
891 (A,106,233)	3P CABLE HOLDER	51048-0300

## RESISTORS

R 881 (A,54,235)		RD1/4PU4R7J
------------------	--	-------------

## CAPACITORS

C 406 (A,96,232)	ELECT. CAPACITOR	CEAT471M35
C 881 (A,13,234)	FILM CAPACITOR	CFLA104J2A
C 882 (A,23,239)	FILM CAPACITOR	CFLA104J2A

## **H** FRONT DISPLAY ASSY MISCELLANEOUS

IC 401 (B,121,181)	DISPLAY U-COM	PE5550A
Q 441 (B,230,161)	TRANSISTOR	RT1N241M
Q 442 (B,238,190)	TRANSISTOR	RT1N241M
Q 484 (B,215,190)	TRANSISTOR	2SA1576A
D 403 (B,226,189)	DIODE	1SS355
D 404 (B,235,168)	DIODE	1SS355
D 405 (B,230,156)	DIODE	1SS355

## **D** TRANS2 ASSY MISCELLANEOUS

⚠ IC 853 (A,32,204)	PROTECTOR(7A)	AEK7021
J 21	JUMPER WIRE 11P	D20PYY1130E
CN 1201 (A,35,183)	4P JUMPER CONNECTOR	52147-0410
851 (A,49,207)	11P CABLE HOLDER	51048-1100

## **E** COMPONENT VIDEO ASSY MISCELLANEOUS

IC 551 (B,240,208)	LOGIC IC	TC74HC4052AF
IC 552 (B,260,214)	LOGIC IC	TC74HC4052AF
IC 553 (B,213,206)	VIDEO IC	NJM2581M
JA 551 (A,253,178)	6P RCA PINJACK	XKB3025
JA 552 (A,211,178)	6P RCA PINJACK	XKB3025
CN 551 (A,196,213)	CONNECTOR	9604S-07C
390 (A,235,239)	PCB BINDER	VEF1040

## RESISTORS

R 553 (B,242,194)		RS1/16S750J
R 554 (B,256,193)		RS1/16S750J
R 555 (B,270,193)		RS1/16S750J
R 556 (B,237,194)		RS1/16S750J
R 557 (B,251,196)		RS1/16S750J

R 558 (B,266,186)		RS1/16S750J
R 559 (B,199,196)		RS1/16S750J
R 560 (B,220,195)		RS1/16S750J
R 561 (B,228,193)		RS1/16S750J
R 562 (B,193,195)		RS1/16S750J

R 563 (B,217,199)		RS1/16S750J
R 564 (B,218,195)		RS1/16S750J
R 566 (B,243,218)		RS1/16S102J
R 567 (B,248,202)		RS1/16S102J
R 568 (B,248,204)		RS1/16S102J

R 569 (B,250,218)		RS1/16S102J
R 571 (B,254,228)		RS1/16S102J
R 572 (B,254,226)		RS1/16S102J
R 573 (B,229,202)		RS1/16S0R0J
R 574 (B,264,202)		RS1/16S0R0J

R 581 (B,247,209)		RS1/16S222J
R 582 (A,245,221)		RD1/4PU222J

## CAPACITORS

C 567 (B,262,186)		CKSRYB103K50
C 568 (B,204,186)		CKSRYB103K50
C 569 (B,246,216)		CKSRYB473K50
C 570 (B,233,208)		CKSRYB473K50
C 571 (B,254,213)		CKSRYB473K50

Mark No.	Description	Part No.	Mark No.	Description	Part No.
D 500	(A,216,182) LED(ORANGE)	SLI-343DCW(STU)	R 452	(B,88,97)	RS1/16S272J
D 502	(A,128,161) LED(BLUE)	SLR343BC4T(JKLM)	R 453	(B,144,142)	RS1/16S472J
L 401	(A,242,159) RADIAL INDUCTOR	LFCA2R2J	R 454	(A,101,135)	RD1/4PU681J
V 401	(A,189,200) FL TUBE	XAV3037	R 455	(A,75,136)	RD1/4PU821J
S 447	(A,94,113) SWITCH	VSG1024	R 456	(A,50,136)	RD1/4PU122J
S 448	(A,76,113) SWITCH	VSG1024	R 457	(A,26,136)	RD1/4PU162J
S 449	(A,58,113) SWITCH	VSG1024	R 458	(B,34,114)	RS1/16S272J
S 450	(A,58,92) SWITCH	VSG1024	R 459	(A,108,134)	RD1/4PU472J
S 451	(A,76,92) SWITCH	VSG1024	R 460	(A,133,138)	RD1/4PU681J
S 452	(A,94,92) SWITCH	VSG1024	R 461	(A,152,136)	RD1/4PU821J
S 454	(A,89,136) SWITCH	VSG1024	R 462	(A,183,141)	RD1/4PU122J
S 455	(A,65,136) SWITCH	VSG1024	R 463	(A,200,141)	RD1/4PU162J
S 456	(A,40,136) SWITCH	VSG1024	R 464	(A,233,139)	RD1/4PU272J
S 457	(A,16,136) SWITCH	VSG1024	R 465	(A,166,152)	RD1/4PU472J
S 458	(A,40,113) SWITCH	VSG1024	R 471	(B,40,102)	RS1/16S512J
S 459	(A,114,136) SWITCH	VSG1024	R 472	(A,90,142)	RD1/4PU472J
S 460	(A,138,136) SWITCH	VSG1024	R 550	(B,192,185)	RS1/16S181J
S 461	(A,163,136) SWITCH	VSG1024	R 551	(B,125,156)	RS1/16S391J
S 462	(A,187,136) SWITCH	VSG1024	<b>CAPACITORS</b>		
S 463	(A,212,136) SWITCH	VSG1024	C 401	(B,247,155)	CKSRBY103K50
S 464	(A,236,136) SWITCH	VSG1024	C 402	(B,247,153)	CKSRBY103K50
S 471	(A,40,92) SWITCH	VSG1024	C 403	(A,232,168)	CEAT221M6R3
X 401	(A,149,165) CERAMIC RESONATOR (5.00 MHz)	VSS1142	C 410	(B,60,193)	CKSRBY103K50
CN 401	(A,246,165) 17P CONNECTOR	52044-1745	C 411	(B,62,193)	CKSRBY103K50
515	FL HOLDER(FE)	VNF1096	C 412	(A,49,178)	CEAT470M50
471	(A,34,191) CABLE HOLDER(3P)	51063-0305	C 418	(B,141,179)	CKSRBY104K16
470	(A,37,174) CABLE HOLDER(3P)	51063-0305	C 419	(B,103,183)	CKSRBY103K50
404	(A,197,127) CABLE HOLDER(5P)	51063-0505	C 420	(A,44,184) ELECT. CAPACITOR	CEAT101M35
402	(A,223,169) REMOTE RECEIVER UNIT	GP1UE274XKC1	C 421	(B,160,169)	CKSRBY104K16
<b>RESISTORS</b>			C 441	(B,225,176)	CKSRBY103K50
R 401	(B,144,169)	RS1/16S105J	C 442	(A,239,146)	CEAL470M10
R 402	(B,223,191)	RS1/16S104J	C 451	(B,125,166)	CKSRBY102K50
R 403	(B,220,191)	RS1/16S104J	C 452	(B,103,164)	CKSRBY102K50
R 404	(B,222,176)	RS1/16S472J	C 453	(B,122,166)	CKSRBY102K50
R 405	(B,228,155)	RS1/16S102J	C 454	(B,100,164)	CKSRBY102K50
R 406	(B,226,155)	RS1/16S103J	C 481	(B,140,191)	CCSRCH471J50
R 407	(B,78,176)	RS1/16S473J	C 482	(B,126,201)	CCSRCH221J50
R 408	(B,80,176)	RS1/16S473J	C 483	(B,126,199)	CCSRCH221J50
R 409	(B,75,176)	RS1/16S473J	C 487	(B,84,160)	CKSRBY102K50
R 410	(B,73,176)	RS1/16S473J	C 488	(B,81,160)	CKSRBY102K50
R 411	(B,229,189)	RS1/16S473J	C 489	(B,74,163)	CKSRBY102K50
R 412	(B,235,187)	RS1/16S221J	C 490	(A,71,163)	CKSRBY102K50
R 413	(B,235,184)	RS1/16S221J	<b>ROTARY ENCODER ASSY</b>		
R 414	(B,235,182)	RS1/16S221J	<b>MISCELLANEOUS</b>		
R 415	(B,235,180)	RS1/16S221J	S 502	(A,263,225) SWITCH	VSG1024
R 416	(B,235,178)	RS1/16S221J	S 503	(A,282,225) SWITCH	VSG1024
R 417	(B,223,182)	RS1/16S101J	S 504	(A,300,225) SWITCH	VSG1024
R 419	(B,205,148)	RS1/16S101J	S 505	(A,300,212) SWITCH	VSG1024
R 420	(B,207,148)	RS1/16S101J	S 506	(A,282,212) SWITCH	VSG1024
R 421	(B,209,148)	RS1/16S101J	S 507	(A,263,212) SWITCH	VSG1024
R 422	(B,157,169)	RS1/16S104J	S 513	(A,285,154) ROTARY ENCODER	XSX3005
R 423	(B,131,167)	RS1/16S104J	511	(A,257,183) CABLE HOLDER(5P)	51063-0505
R 424	(B,83,176)	RS1/16S104J	<b>RESISTORS</b>		
R 425	(B,206,185)	RS1/16S104J	R 503	(B,275,224)	RS1/16S681J
R 448	(B,87,114)	RS1/16S681J	R 504	(B,294,224)	RS1/16S821J
R 449	(B,69,114)	RS1/16S821J	R 505	(B,301,219)	RS1/16S122J
R 450	(B,58,102)	RS1/16S122J			
R 451	(B,69,93)	RS1/16S162J			

Mark No.	Description	Part No.
R 506	(B,294,213)	RS1/16S162J
R 507	(B,275,213)	RS1/16S272J

Mark No.	Description	Part No.
C 816	(A,191,94)	CEAT101M10
C 817	(B,202,98)	CKSRYB103K25
C 818	(B,182,95)	CKSRYB103K25
C 819	(A,176,95)	CEAT221M10

## J POWER KEY ASSY

### MISCELLANEOUS

D 501	(A,37,229) LED(BLUE)	SLR343BC4T(JKLM)
S 501	(A,29,226) SWITCH	VSG1024
501	(A,40,210) CABLE HOLDER(3P)	51063-0305

### RESISTORS

R 501	(B,37,234)	RS1/16S391J
-------	------------	-------------

## K JOG ASSY

### MISCELLANEOUS

S 512	(A,96,226) ROTARY ENCODER	XSX3009
512	(A,66,236) CABLE HOLDER(3P)	51063-0305

## M DIGITAL INPUT ASSY

### MISCELLANEOUS

F 1901	(B,214,228) INDUCTOR	CTF1295
JA 1900	(A,206,201) OPT. LINK IN	GP1FAV51RKBF
JA 1901	(A,220,201) OPT. LINK IN	GP1FAV51RKBF
KN 1902	(A,249,206) SCREW PLATE	VNE1948
CN 1903	(A,236,221) CONNECTOR	VKN1181

### RESISTORS

R 1900	(B,211,215)	RS1/16S101J
R 1901	(B,222,215)	RS1/16S101J

### CAPACITORS

C 1900	(B,205,215)	CKSRYB104K25
C 1901	(B,217,215)	CKSRYB104K25
C 1903	(B,211,230)	CKSRYB103K50
C 1904	(A,208,228)	CEAL101M10
C 1905	(B,228,233)	CKSRYB104K25

C 1906	(B,230,233)	CKSRYB103K50
C 1907	(B,232,233)	CCSRCH101J50
C 1908	(B,236,233)	CKSRYB102K50

## N REGULATOR ASSY

### MISCELLANEOUS

△ IC 801	(A,147,89) REGULATOR IC	KIA7812API
△ IC 802	(A,164,89) REGULATOR IC	KIA7912PI
△ IC 807	(A,198,89) REGULATOR IC	BA50BC0T
△ IC 808	(A,181,89) REGULATOR IC	BA50BC0T
D 810	(A,172,94) DIODE	MTZJ6R2(B)

D 813	(A,187,94) DIODE	MTZJ6R2(B)
CN 800	(A,194,113) 11PJUMPER CONNECTOR	52147-1110

### RESISTORS

R 801	(A,136,95) METAL OXIDE RESISTOR	RS3LMF331J
R 819	(B,195,96)	RS1/16S0R0J

### CAPACITORS

C 803	(B,147,97)	CKSRYB103K25
C 804	(B,166,97)	CKSRYB103K25
C 805	(A,147,105)	CEJQ101M16
C 806	(A,159,99)	CEAT101M16

## O HEAD PHONE ASSY

### MISCELLANEOUS

Q 1551	(B,208,48) TRANSISTOR	2SC5938A
Q 1552	(B,203,39) TRANSISTOR	2SC5938A
J 47	6P PARALLEL WIRE	XDX3065
JA 1551	(A,163,30) HEADPHONE JACK	XKB3066
KN 1551	(A,193,23) WRAPPING TERMINAL	VNF1084

1551	(A,220,28) 6P CABLE HOLDER	51048-0600
------	----------------------------	------------

### RESISTORS

△ R 1551	(A,218,56) METAL OXIDE RESISTOR	RS2LMF331J
△ R 1552	(A,207,42) METAL OXIDE RESISTOR	RS2LMF331J
△ R 1553	(A,202,45) METAL OXIDE RESISTOR	RS1LMF151J
△ R 1554	(A,194,45) METAL OXIDE RESISTOR	RS1LMF151J
R 1555	(B,208,32)	RS1/16S472J

R 1556	(B,210,43)	RS1/16S472J
R 1557	(B,212,30)	RS1/16S102J

### CAPACITORS

C 1551	(B,194,40)	CKSRYB223K50
C 1552	(B,205,49)	CKSRYB223K50
C 1553	(B,169,39)	CKSRYB103K50
C 1554	(B,169,37)	CCSRCH471J50
C 1555	(B,169,34)	CKSRYB104K16

C 1556	(B,167,24)	CKSRYB103K50
C 1557	(B,170,24)	CCSRCH471J50
C 1558	(B,172,24)	CKSRYB104K16
C 1561	(A,196,64) ELECT. CAPACITOR	CEANP470M50
C 1562	(A,215,44) ELECT. CAPACITOR	CEANP470M50

## P VIDEO ASSY

### MISCELLANEOUS

IC 301	(B,46,32) VIDEO SW IC	NJM2595M
IC 303	(B,37,73) VIDEO SW IC	NJM2243M
IC 851	(B,100,70) CHARACTER GENERATOR	PDC162A
△ Q 301	(A,86,47) TRANSISTOR	2SD1858X
△ Q 302	(A,66,52) TRANSISTOR	2SB1237X

Q 303	(B,24,81) TRANSISTOR	2SC5938A
Q 852	(B,72,83) TRANSISTOR	2SC4081
D 301	(B,44,40) DIODE	1SS355
D 302	(B,41,44) DIODE	1SS355
D 303	(B,81,61) DIODE	UDZS6R2(B)

D 304	(B,73,59) DIODE	UDZS6R2(B)
D 307	(B,99,26) DIODE	UDZS5R1(B)
D 308	(B,60,23) DIODE	DAN202U
D 359	(B,93,53) DIODE	1SS355
D 360	(B,96,48) DIODE	1SS355

D 651	(B,76,75) DIODE	DAP202K
L 302	(B,34,9) CHIP SOLID INDUCTOR	QTL1013
L 303	(B,26,13) CHIP SOLID INDUCTOR	QTL1013
L 304	(B,26,15) CHIP SOLID INDUCTOR	QTL1013
L 305	(B,21,23) CHIP SOLID INDUCTOR	QTL1013
L 306	(B,72,10) CHIP SOLID INDUCTOR	QTL1013

Mark No.	Description	Part No.
L 853	(B,101,61) CHIP COIL	LCYA330J2520
JA 305	(A,14,58) PIN JACK(4P)YELLOW	XKB3048
JA 351	(A,15,20) MINI JACK(4P) /W SW	XKN3015
JA 352	(A,18,9) JACK	VKB1243
X 851	(A,102,57) CRYSTAL RESONATOR (14.31818 MHz)	ASS1056
CN 302	(A,64,84) 6P SOCKET	KP200TA6L
CN 303	(A,81,7) CONNECTOR	9604S-19C
CN 306	(A,14,37) 2P PIN JACK	XKB3041
CN 310	(A,46,7) CONNECTOR	9604S-07C
CN 354	(A,105,20) CONNECTOR POST	B2B-PH-K-S

### RESISTORS

R 301	(B,37,20)	RS1/16S750J
R 302	(B,31,60)	RS1/16S750J
R 303	(B,31,33)	RS1/16S750J
R 304	(B,31,66)	RS1/16S750J
R 305	(B,23,51)	RS1/16S750J
R 306	(B,28,51)	RS1/16S750J
R 307	(B,56,25)	RS1/16S102J
R 308	(B,57,29)	RS1/16S102J
R 309	(B,57,27)	RS1/16S151J
R 310	(B,57,31)	RS1/16S102J
R 311	(B,42,23)	RS1/16S102J
R 312	(B,60,25)	RS1/16S102J
△ R 313	(A,85,57) METAL OXIDE RESISTOR	RS3LMF390J
R 314	(B,84,61)	RS1/16S152J
R 315	(B,64,59)	RS1/16S152J
△ R 316	(A,67,39) METAL OXIDE RESISTOR	RS3LMF390J
R 317	(B,22,75)	RS1/16S102J
R 318	(B,26,77)	RS1/16S122J
R 319	(B,26,75)	RS1/16S472J
R 390	(B,73,15)	RS1/16S102J
R 391	(B,34,39)	RS1/16S0R0J
R 392	(B,33,54)	RS1/16S0R0J
R 393	(B,49,39)	RS1/16S0R0J
R 394	(B,26,27)	RS1/16S0R0J
R 852	(B,101,49)	RS1/16S471J
R 853	(B,94,47)	RS1/16S103J
R 854	(B,92,60)	RS1/16S103J
R 855	(B,105,82)	RS1/16S102J
R 856	(B,78,80)	RS1/16S221J
R 857	(B,74,80)	RS1/16S103J

### CAPACITORS

C 304	(B,35,18)	CKSRYB221K50
C 305	(B,23,66)	CKSRYB221K50
C 306	(B,25,51)	CKSRYB221K50
C 307	(A,35,36)	CEAT470M25
C 308	(A,52,54)	CEAT470M25
C 309	(A,31,46)	CEAT470M25
C 310	(A,54,43)	CEAT101M16
C 311	(B,82,48)	CKSRYB473K25
C 313	(B,75,42)	CKSRYB473K25
C 333	(B,22,77)	CKSRYB331K50
C 338	(A,60,38)	CEAT101M16
C 339	(B,37,24)	CKSRYB104K25
C 340	(B,56,37)	CKSRYB104K25
C 347	(B,56,22)	CCSRCH470J50
C 350	(A,38,80)	CEAT101M16

Mark No.	Description	Part No.
C 379	(B,31,54)	CKSRYB103K50
C 380	(A,43,74)	CEAT101M16
C 390	(A,30,75) ELECTR.CAPACITOR	CEAT102M10
C 391	(A,49,65)	CEAT470M16
C 392	(B,49,67)	CKSRYB104K25
C 444	(B,46,67)	CKSRYB104K25
C 851	(A,82,80)	CEAT101M10
C 852	(A,90,71)	CEAT101M10
C 853	(B,107,82)	CKSRYB473K25
C 854	(B,91,62)	CKSRYB473K25
C 855	(B,106,53)	CCSRCH150J50
C 856	(B,103,53)	CCSRCH180J50
C 857	(B,101,53)	CCSRCH240J50
C 858	(B,99,53)	CCSRCH240J50
C 859	(B,99,47)	CCSRCH470J50
C 860	(B,98,82)	CKSRYB473K25
C 861	(B,100,82)	CKSRYB473K25
C 862	(B,102,82)	CCSRCH101J50
C 864	(A,68,76)	CEAT101M10
C 1360	(B,18,51)	CKSRYB103K50

## Q PRIMARY ASSY MISCELLANEOUS

△ IC 51	(B,236,11) IC	NJM78L05UA
Q 51	(B,267,14) DIGITAL TR(SC-70)	RT1N431M
D 51	(B,298,20) BRIDGE DIODE	DF06SA
D 55	(A,304,21) DIODE	1SR139-400
D 56	(A,271,21) DIODE	1SS133
D 57	(A,266,25) DIODE	1SS133
D 58	(A,314,13) DIODE	MTZJ5R1(B)
△ L 51	(A,253,73) LINE FILTER	XTF3004
H 51	(A,231,34) FUSE CLIP	AKR7001
H 52	(A,250,34) FUSE CLIP	AKR7001
J 52	JUMPER WIRE	D20PYY0410E
KN 51	(A,318,25) WRAPPING TERMINAL	VNF1084
KN 3001	(A,223,117) SCREW PLATE	VNE1948
△ RY 51	(A,271,57) JOE LOWPOWER RELAY	ASR7013
△ T 51	(A,288,56) STANDBY TRANSFORMER	ATT7040
△ CN 51	(A,236,47) AC CODE SOCKET	RKP1751
55	(A,317,9) 4P CABLE HOLDER	51048-0400

### RESISTORS

R 52	(A,275,11)	RD1/2PM270J
R 53	(A,307,12)	RD1/4PU332J
R 54	(A,319,16)	RD1/4PU103J

### CAPACITORS

△ C 51	(A,261,64) FILM CAPACITOR	ACE7013
△ C 52	(A,265,57) SAFETY CAPACITOR	XCG3010
C 53	(A,291,21) ELECT. CAPACITOR	CEAT102M16
C 54	(A,300,11)	CEAT470M25
C 55	(A,307,21)	CKPUYF103Z25
C 56	(A,311,21)	CKPUYF103Z25
C 57	(A,314,21)	CKPUYF103Z25

## R FRONT VIDEO ASSY MISCELLANEOUS

JA 902	(A,167,224) 3P PIN JACK	XKB3063
--------	-------------------------	---------

Mark No.	Description	Part No.	Mark No.	Description	Part No.
CN 901	(A,126,230) CONNECTOR POST	B5B-PH-K-S	C 952	(B,35,54)	CKSRYP103K50
<b>RESISTORS</b>			C 953	(B,33,54)	CKSRYP104K50
R 901	(B,161,224)	RS1/16S331J	C 956	(A,43,68) CHIP ELECT.CAPACITOR	CEVW100M50
R 902	(B,176,220)	RS1/16S331J	C 957	(A,52,70)	CKSRYP103K50
R 903	(B,157,224)	RS1/16S474J	C 958	(A,43,79) CHIP ELECT.CAPACITOR	CEVW100M50
R 904	(B,171,220)	RS1/16S474J	C 959	(A,48,67)	CKSRYP471K50
R 905	(B,139,233)	RS1/16S750J	C 960	(B,33,59)	CCSRCH101J50
<b>CAPACITORS</b>			C 962	(A,37,78)	CKSRYP103K50
C 901	(B,164,224)	CCSRCH101J50	C 963	(A,34,104) CHIP ELECT.CAPACITOR	CEVW100M50
C 902	(B,178,220)	CCSRCH101J50	C 964	(B,34,77)	CCSRCH330J50
C 903	(A,136,234) ELECTR. CAPACITOR	CEAL470M25	C 965	(B,45,66)	CCSRCH330J50
C 906	(B,161,233)	CKSRYP224K16	C 967	(A,35,67) CHIP ELECT.CAPACITOR	CEVW100M50
C 907	(B,163,233)	CKSRYP471K50	C 968	(A,32,79) CHIP ELECT.CAPACITOR	CEVW100M50
C 908	(B,158,233)	CKSRYP103K25	C 969	(B,60,47)	CKSRYP104K16
C 909	(B,153,233)	CKSRYP224K16	C 970	(A,50,46)	CEVW101M16
C 910	(B,151,233)	CKSRYP471K50			
C 911	(B,148,233)	CKSRYP103K25			
C 915	(B,159,224)	CCSRCH101J50			
C 916	(B,173,220)	CCSRCH101J50			

## T FRONT IN ASSY MISCELLANEOUS

C	IC 951	(B,37,70) DUAL OP-AMP	NJM4565MD	IC 171	TC74VHC157F51
	IC 952	(A,59,63) IC	TC4066BFN	IC 191,331,881	TC74VHC08F51
	Q 951	(A,51,60) TRANSISTOR	RT1N241M	IC 201	DSPC56371AF180
	Q 952	(B,52,66) DIGITAL TR(SC-70)	RT1P241M	IC 202	TC7WH125FU
	D 951	(B,44,73) DIODE	UDZS5R1(B)	IC 251	PDC173A8
	D 952	(A,38,97) DIODE	UDZS5R1(B)	IC 261	TC7WHU04FU
	D 953	(A,38,93) DIODE	UDZS5R1(B)	IC 271	ML87V5002
	D 957	(B,30,59) DIODE	DAN217U	IC 301	AK4626AVQ
	L 970	(A,60,38) COIL	ATH7015	IC 351	TC74VHCT541AFTS1
	JA 952	(A,78,58) STEREO MINI JACK	XKN3017	IC 401	TCC8600-00X-EA-UG
	JA 953	(A,79,38) USB CONNECTOR	XKP3086	△ IC 402	S-1200B18-M5
D	KN 951	(A,46,34) WRAPPING TERMINAL	VNF1084	IC 461	HY57V641620FTP-6
	CN 953	(A,40,51) CONNECTOR	B4B-PH-K-S	IC 462	AYW7236
	CN 956	(A,46,97) CONNECTOR	9604S-09C	△ IC 471	AAT4618IGV-0.5-1
				IC 481	341S2154
				IC 611	CXB1444R
				IC 631	S-24CS02AFT
				IC 632	TC74LVX4053FT
				IC 651	SI19013CLU
				IC 701	SI19134CTU
				IC 801	PEG118A
				IC 861	AYW7202
E				IC 871	TC74VHC125F51
				IC 882	TC74VHCT08AFTS1
				△ IC 891	NJM2872BF33
				Q 71,602,604,631	DTC114YUA
				Q 201	RT1N241M
				Q 401	2SA1577
				Q 402,471,632,634	RT1N431M
				Q 601,603,633,635	RT1P241M
				Q 751	UMB1N
				Q 752	DTC114YUA
				D 1,21	UDZS5R6(B)
				D 61	RB551V-30
F				△ D 71	D1FM3
				D 301	MA152WA

## CAPACITORS

Mark No.	Description	Part No.	Mark No.	Description	Part No.
D 302		MA152WK			
D 701		UDZS5R1(B)	R 663		RAB4CQ470J
D 861		RB501V-40	R 668,669,721		RAB4CQ473J
			R 681-685,687,688		RAB4CQ220J
			R 704		RS1/16SS6800F
			R 723-728		RAB4CQ473J
			R 764		RAB4CQ220J
			R 781-785,891		RS1/16S0R0J
			Other Resistors		RS1/16SS###J
<b>MISCELLANEOUS</b>			<b>CAPACITORS</b>		
L 1-3	CHIP SOLID INDUCTOR	ATL7002	C 7,78,107,173		CKSSYB102K50
L 71,611,651,652	CHIP BEADS	ATL7010	C 9,74,92,113		CKSSYB103K16
△ L 72	POWER INDUCTOR(22U)	DTL1100	C 10,12,172,203		CKSSYB471K50
L 101,102	CHIP SOLID INDUCTOR	QTL1013	C 11,102,105,106		CKSSYB104K10
L 171,191	CHIP SOLID INDUCTOR	QTL1013	C 21,51,230,303		CEVW101M16
L 201,204	CHIP SOLID INDUCTOR	QTL1013			
L 202,203	CHIP SOLID INDUCTOR	ATL7002	C 22-25		CKSRYB105K10
L 251,261	CHIP SOLID INDUCTOR	QTL1013	C 52,54,55		CKSRYB104K16
L 271,301	CHIP SOLID INDUCTOR	QTL1013	C 57-59,63,65		CKSRYB104K16
L 302,331	CHIP SOLID INDUCTOR	QTL1013	C 61,613,654,655		CKSRYB105K16
L 351,401	CHIP SOLID INDUCTOR	QTL1013	C 62,93,421,893		CKSQYB225K10
L 402	INDUCTOR	LCTC100K1608			
L 403,404	CHIP SOLID INDUCTOR	QTL1013	C 67,70,91,441		CKSRYB104K16
L 441	CHIP FERRITE BEADS	VTL1169	C 71-73,80,82		DCH1201
L 442	COIL	VTH1043	C 75		CCSSCH121J50
L 461,462	CHIP SOLID INDUCTOR	QTL1013	C 77		CKSSYB473K16
L 481	CHIP SOLID INDUCTOR	QTL1013	C 79		CCSSCH471J16
L 653-655	CHIP SOLID INDUCTOR	QTL1013			
L 656,657,701-705	CHIP BEADS	ATL7010	C 85,86		CKSRYB102K50
△ L 751-754	COIL	ATH7022	C 87		CCSRCH101J50
L 801	CHIP BEADS	ATL7010	C 103,108,318		CEVW470M6R3
JA 101	JACK	VKB1159	C 104,110,192,261		CCSRCH471J50
JA 601,602,701	HDMI CONNECTOR	AKP1318	C 109,171,191,202		CKSSYB104K10
X 261	CRYSTAL RESONATOR (24.576 MHz)	XSS3003			
X 402	CRYSTAL OSCILLATOR	CSS1614	C 111		CKSRYB474K10
X 481	CRYSTAL OSCILLATOR (32.768 kHz)	ASS1172	C 204,206,208,210		CKSSYB104K10
X 651	CRYSTAL RESONATOR (28.322 MHz)	ASS7085	C 209,214,216,218		CKSSYB471K50
X 801	CERAMIC RESONATOR (15.7 MHz)	XSS3004	C 215,217,219,222		CKSSYB104K10
CN 1	13P SOCKET	XKP3077	C 220,301,431,667		CKSSYB103K16
CN 2	21P SOCKET	XKP3081			
CN 3	CONNECTOR	9604S-35C	C 221,225,309-314		CKSSYB471K50
CN 5	5P CONNECTOR	VKN1374	C 224,226,228,232		CKSSYB104K10
CN 401	CONNECTOR	AKM1275	C 229		CEVW101M4
CN 801	7P CONNECTOR	VKN1411	C 252,262,271,273		CKSSYB104K10
JH 501	PCB BINDER	VEF1040	C 264,265		CCSSCH8R0D50
<b>RESISTORS</b>					
R 21		RS1/16SS2002F	C 275,277,304,306		CKSSYB104K10
R 22,24,74		RS1/16SS1202F	C 305,484,802,805		CCSSCH101J50
R 23		RS1/16SS1000F	C 315,425,443,455		CEVW101M16
R 42,44,45,48		RAB4CQ104J	C 316,320,332,352		CKSSYB104K10
R 51,62,64,92		RS1/16S0R0J	C 317,402,404,406		CKSSYB471K50
R 63,77,80		RS1/10S0R0J	C 321,322		CKSSYB102K50
R 75		RS1/16SS5100F	C 401,403,405,407		CKSSYB104K10
R 76		RS1/16SS1002F	C 408,410,412,416		CKSSYB471K50
R 103,108,171,173		RAB4CQ101J	C 409,411,415,417		CKSSYB104K10
R 110,442,443		RS1/16S0R0J	C 413		CCSRCH100D50
R 111		RS1/16SS1802F	C 414		CCSRCH471J50
R 172,226,229,272		RAB4CQ470J	C 418,424,427,430		CKSSYB471K50
R 174,202,271,273		RAB4CQ101J	C 419,423,426,429		CKSSYB104K10
R 191-193		RS1/16S101J	C 420		CKSSYB122K50
R 203		RAB4CQ103J	C 422		CCSRCH331J50
R 279,317,353,354		RAB4CQ101J	C 432,434,454,461		CKSSYB104K10
R 306		RS1/16S4R7J	C 433,435,436		CKSSYB471K50
R 488		RS1/16SS1003F	C 442,861,873		CKSRYB104K16
R 607-610,621-625		RS1/16S0R0J	C 451,457		CKSQYB105K10
R 612		RS1/16SS4701F	C 462-464,466,468		CKSSYB471K50

Mark No.	Description	Part No.	Mark No.	Description	Part No.
A	C 467,481,485,611	CKSSYB104K10		<b>FM/AM TUNER UNIT</b> FM/AM TUNER UNIT has no service parts.	
	C 471	CKSSYB104K16			
	C 472	CKSQYB105K16			
	C 482,483	CCSSCH5R0C50			
	C 486	CKSSYB471K50			
	C 612,801	CEVW101M16			
	C 614-624,631,632	CKSSYB104K10			
	C 651,656,701,703	DCH1201			
	C 652,653,702,704	CKSQYB106K6R3			
	C 657,672,679,712	CKSRYP105K16			
B	C 661-666,668-671	CKSSYB104K10			
	C 673-677,680-683	CKSSYB104K10			
	C 678,713,803,892	CKSSYB103K16			
	C 691	CCSSCH120J50			
	C 692	CCSSCH100D50			
	C 705	CKSQYB106K6R3			
	C 711,714,716,718	CKSSYB104K10			
	C 715,717,719,723	CKSRYP105K16			
	C 720-722,751,804	CKSSYB104K10			
	C 724	CKSRYP105K16			
	C 731-738	VCG1066			
	C 806,807,862,871	CKSSYB104K10			
	C 808	CCSSCH101J50			
C	C 872,881,882,891	CKSSYB104K10			

## **W** HDMI ASSY (VSX-818V-K)

### **SEMICONDUCTORS**

	IC 101	CXB1444R
	IC 102	TC7MB3253FK
	△ IC 901	MM1593DF
	△ IC 911	NJM2872BF05
	Q 121-123,152,154	RT1N241M
	Q 151,153	RT1P241M
D	D 381	UDZS5R1(B)

### **MISCELLANEOUS**

	L 101,1001 CHIP BEADS	ATL7010
	△ L 351-354 COIL	ATH7022
	JA 101,102,301 HDMI CONNECTOR	AKP1318
	CN 1001 7P CONNECTOR	52044-0745
	CN 1002 5P CONNECTOR	VKN1236

### **RESISTORS**

	R 102	RS1/16S4701F
	R 121-123	RS1/16SS103J
E	Other Resistors	RS1/16S###J

### **CAPACITORS**

	C 101,102,104-111	CKSRYP104K16
	C 103	CEVW101M16
	C 113-115,351,911	CKSRYP104K16
	C 121	CKSSYB104K10
	C 901	CKSRYP105K16
	C 902	CCSRCH471J50
	C 903,913	CKSQYB225K10
	C 912	CKSRYP103K50
	C 1001,1011	CKSRYP104K16
F	C 1002	DCH1201
	C 1012	CKSRYP102K50
	C 1013	CCSRCH101J50